

published in Part 2 of the *Gazette officielle du Québec* of 1 November 2023 with a notice that it could be made by the Government on the expiry of 45 days following that publication;

WHEREAS it is expedient to make the Regulation without amendment;

IT IS ORDERED, therefore, on the recommendation of the Minister of the Environment, the Fight Against Climate Change, Wildlife and Parks:

THAT the Regulation respecting the 2023 upper limit of kill for moose, attached to this Order in Council, be made.

DOMINIQUE SAVOIE
Clerk of the Conseil exécutif

Regulation respecting the 2023 upper limit of kill for moose

Act respecting hunting and fishing rights in the James Bay and New Québec territories (chapter D-13.1, s. 78, 1st par., subpar. *f* and 3rd par.)

1. The upper limit of kill for moose allocated to the Native people and non-Natives in Area 17 determined by the Regulation respecting fishing and hunting areas (chapter C-61.1, r. 34) is 104 moose for the period from 1 July 2023 to 30 June 2024.

2. This Regulation comes into force on the fifteenth day following the date of its publication in the *Gazette officielle du Québec*.

106727

M.O., 2024

Order 2024-04 of the Minister of Transport and Sustainable Mobility dated 20 February 2024

Highway Safety Code
(chapter C-24.2, s. 633.2)

Use of flexible folding aerodynamic systems for road vehicles

THE MINISTER OF TRANSPORT AND SUSTAINABLE MOBILITY,

CONSIDERING section 633.2 of the Highway Safety Code (chapter C-24.2), which provides that the Minister of Transport and Sustainable Mobility may, by order and after

consultation with the Société de l'assurance automobile du Québec, suspend the application of a provision of the Code or the regulations for the period specified by the Minister if the Minister considers that it is in the interest of the public and is not likely to compromise highway safety;

CONSIDERING that section 633.2 of the Code also provides that the Minister may prescribe any rule, applicable when using the exemption, that ensures an equivalent level of safety in the Minister's opinion;

CONSIDERING that section 633.2 of the Code provides that the publication requirement set out in section 8 of the Regulations Act (chapter R-18.1) does not apply to an order made under section 633.2;

CONSIDERING the revocation of the Ministerial Order concerning the use of flexible folding aerodynamic systems for road vehicles (chapter C-24.2, r. 43.2) on 10 October 2023;

CONSIDERING that it is still advisable to allow the use of flexible folding aerodynamic systems at the rear of a road vehicle;

CONSIDERING that the Minister considers that the use of flexible folding aerodynamic systems at the rear of a road vehicle, in compliance with the conditions imposed, is in the interest of the public and is not likely to compromise highway safety;

CONSIDERING that the Minister considers that the rules the Minister prescribes, applicable when using the exemption, ensure an equivalent level of safety;

CONSIDERING that the Société de l'assurance automobile du Québec has been consulted on the suspension;

ORDERS AS FOLLOWS:

1. Section 474 of the Highway Safety Code (chapter C-24.2) is suspended with respect to a flexible folding aerodynamic system installed at the rear of a road vehicle provided that, as shown,

(1) no part of the system located at more than 1.9 m from the ground exceeds the rear end of the vehicle by more than 152 cm when extended;

(2) no part of the system located at less than 1.9 m from the ground exceeds a virtual line connecting the following points when extended:

(a) a point located at 1.74 m from the ground and 121 cm from the rear end of the vehicle;

(b) a point located at the rear end and the lowest part of the vehicle bumper or, if there is no bumper, a point located at the lowest part of the rear end of the vehicle;

(3) no part of the system exceeds the rear end of the vehicle by more than 30.5 cm when folded.

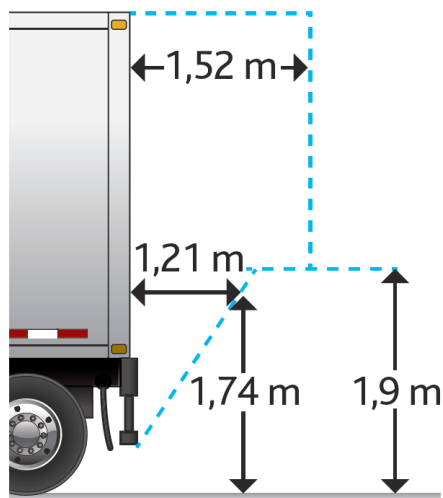

2. With respect to a flexible folding aerodynamic system installed at the rear of a road vehicle, the second paragraph of section 4.1 of the Vehicle Load and Size Limits Regulation (chapter C-24.2, r. 31) is suspended and replaced by the following:

“The same applies to the flexible folding aerodynamic system located at the rear of a road vehicle, provided that, as shown,

(1) no part of the system located at more than 1.9 m from the ground exceeds the rear end of the vehicle by more than 152 cm when extended;

(2) no part of the system located at less than 1.9 m from the ground exceeds a virtual line connecting the following points when extended:

(a) a point located at 1.74 m from the ground and 121 cm from the rear end of the vehicle;

(b) a point located at the rear end and the lowest part of the vehicle bumper or, if there is no bumper, a point located at the lowest part of the rear end of the vehicle;

(3) no part of the system exceeds the rear end of the vehicle by more than 30.5 cm when folded.

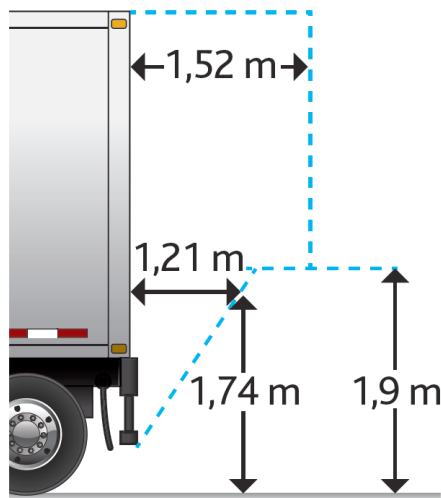

3. With respect to a flexible folding aerodynamic system installed at the rear of a semi-trailer of a road train, subparagraphs 3 and 4 of the first paragraph of section 3 of the Special Road Train Operating Permits Regulation (chapter C-24.2, r. 36) are suspended and replaced by the following:

“(3) the first semi-trailer has a maximum length of 16.20 m and a minimum length of 12 m, in the case of a type B double train, or 13.50 m in the case of a type A or C double train, the whole without taking into account the presence of a flexible folding aerodynamic system located at the rear of the semi-trailer, provided that, as shown,

(a) no part of the system located at more than 1.9 m from the ground exceeds the rear end of the vehicle by more than 152 cm when extended;

(b) no part of the system located at less than 1.9 m from the ground exceeds a virtual line connecting the following points when extended:

i. a point located at 1.74 m from the ground and 121 cm from the rear end of the vehicle;

ii. a point located at the rear end and the lowest part of the vehicle bumper or, if there is no bumper, a point located at the lowest part of the rear end of the vehicle;

(c) no part of the system exceeds the rear end of the vehicle by more than 30.5 cm when folded.

(4) the second semi-trailer has a maximum length of 16.20 m and a minimum length of 12 m, without taking into account the presence of a flexible folding aerodynamic system located at the rear of a road vehicle and complying with subparagraph 3.”.

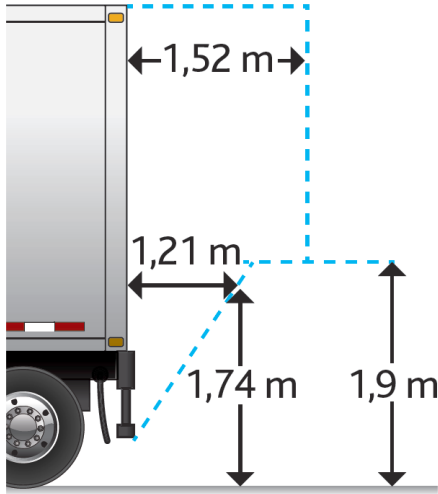

4. This Order comes into force on the fifteenth day following the date of its publication in the *Gazette officielle du Québec*. It is revoked on 1 July 2026.

Québec, 20 February 2024

GENEVIÈVE GUILBAULT
Minister of Transport and Sustainable Mobility

106723