

---

## Draft Regulations

---

### Draft Regulation

Building Act  
(chapter B-1.1)

#### **Construction Code — Chapter I.1, Energy Efficiency of Buildings — Amendment**

Notice is hereby given, in accordance with sections 10 and 11 of the Regulations Act (chapter R-18.1), that the Regulation to amend the Construction Code, appearing below, may be approved by the Government, with or without amendment, on the expiry of 45 days following this publication.

The draft Regulation amends Chapter I.1, Energy Efficiency of Buildings, of the Construction Code (chapter B-1.1, r. 2) in order to incorporate by reference the National Energy Code of Canada for Buildings 2020, with amendments to reflect the specific needs of Québec. The draft Regulation provides for the extension of most of the Québec amendments made to the previous version.

The proposed measures will not result in additional construction costs, since they extend energy efficiency requirements already in force.

Further information on the draft Regulation may be obtained by contacting Nathalie Lessard, architect, Régie du bâtiment du Québec, 255, boulevard Crémazie Est, bureau 100, Montréal (Québec) H2M 1L5; email: [projet.reglement@rbq.gouv.qc.ca](mailto:projet.reglement@rbq.gouv.qc.ca).

Any person wishing to comment on the draft Regulation is requested to submit written comments within the 45-day period to Caroline Hardy, Secretary General and Director of Institutional Affairs, Régie du bâtiment du Québec, 800, place D'Youville, 16<sup>e</sup> étage, Québec (Québec) G1R 5S3; email: [projet.reglement.commentaires@rbq.gouv.qc.ca](mailto:projet.reglement.commentaires@rbq.gouv.qc.ca).

MICHEL BEAUDOIN  
*President and Chief Executive Officer,  
Régie du bâtiment du Québec*

---

## Regulation to amend the Construction Code

### Building Act

(chapter B-1.1, s. 173, 1st par., 2nd par., 3rd par., subpars. 1 and 6, 4th par., ss. 176, 176.1, 178, 185, pars. 0.1, 0.4 and 38, and s. 192)

1. The Construction Code (chapter B-1.1, r. 2) is amended in section 1.1.1 by replacing “the “National Energy Code of Canada for Buildings 2015” (NRCC 56191)” in the first paragraph by “the “National Energy Code of Canada for Buildings 2020” (NRCC-CONST-56438E)”.

2. Section 1.1.6 is replaced by the following:

“1.1.6. The amendments to the Code are the following:

Articles	Amendments
<p><b>Division A</b> <b>Part 1</b></p>	
<p><b>1.1.1.1.</b></p>	<p>Replace Sentence (1) by the following:</p> <p>“<b>1)</b> Except as provided in Sentence (3) and as provided in sections 1.1.2 and 1.1.3 of the Construction Code (chapter B-1.1, r. 2) made under the Building Act (chapter B-1.1), this Code applies</p> <p>a) to the design and construction of</p> <p style="padding-left: 20px;">i) all new <i>buildings</i>, and</p> <p style="padding-left: 20px;">ii) all new swimming pools designated as facilities intended for use by the public under section 10.03 of the Construction Code, and</p> <p>b) to <i>additions</i>.</p> <p>(See Note A-1.1.1.1.(1).)”.</p> <hr/> <p>Strike out Sentence (2).</p>

1.1.1.2.	<p>Add the following line after “1.1.1.2. <b>Building Parameters Covered by this Code</b>”:</p> <p>“(See Note A-1.1.1.2.)”.</p>
1.2.1.1.	<p>Insert the following in Clause (1)(b) after “applicable acceptable solutions”:</p> <p>“and approved by the Régie du bâtiment du Québec or, in the case of <i>buildings</i> or equipment on which the Board has no jurisdiction, by the <i>authority having jurisdiction</i>”.</p>
1.3.3.1.	<p>Replace the heading of the Article by the following:</p> <p>“1.3.3.1. <b>Application of Parts 1 to 8</b>”;</p> <hr/> <p>Replace “Parts 1, 3 to 8 and 10” by “Parts 1 to 8” in Sentence (1).</p>
1.4.1.2.	<p>Replace respectively in Sentence (1) the following terms defined below:</p> <p>“<i>Authority having jurisdiction</i>* means the Régie du bâtiment du Québec, a regional county municipality or a local municipality.”;</p> <p>“<i>Boiler</i>* means pressure equipment, other than a <i>service water heater</i><sup>†</sup>, equipped with a direct energy source, used to heat a heat-carrying liquid or transform it into steam.”;</p> <p>“<i>Grade</i>* means the lowest of the average levels of finished ground, measured along each exterior wall of a building required to face a street by Subsection 3.2.2. or Subsection 9.10.20.”;</p> <p>“<i>Floor surface area</i> means the area of a space or group of spaces, measured from the exterior surface of the perimeter walls, by the axis of party walls and interior walls and the virtual separation between interconnected spaces, at or near floor level, including the area occupied by columns, interior walls and openings in the floor.”;</p> <p>“<i>Interior lighting power allowance</i> means lighting power allocated to illuminate the interior of a space or group of spaces.”;</p> <p>“<i>Service water</i> means the drinking water for plumbing systems.”;</p> <p>“<i>Thermal block</i> means a space or group of spaces that is considered as one homogeneous space for modeling purposes. A <i>thermal block</i> shall be:</p> <p>(a) one <i>temperature-control zone</i>,</p> <p>(b) a group of <i>temperature-control zones</i></p>

	<p>(i) that are served by the same HVAC system or by HVAC systems that may be considered to be identical,</p> <p>(ii) that are operated and controlled similarly,</p> <p>(iii) whose function and envelope characteristics are sufficiently similar that the heating and cooling energy consumption obtained by modeling the group of zones as a <i>thermal block</i> is not significantly different from what would be obtained by summing the results for the individual zones modeled separately, and</p> <p>(iv) whose azimuth of the glazed exterior facades of the group of <i>temperature-control zones</i> varies by no more than 45°, or</p> <p>(c) a zone consisting entirely of <i>conditioned spaces</i> that are indirectly heated, cooled or ventilated.</p> <p>(See Note A-1.4.1.2.(1).)”.  <hr/> </p> <p>Insert “(See Note A-1.4.1.2.(1).)” at the end of the defined term “<i>Exterior lighting</i>” in Sentence (1);  <hr/> </p> <p>Insert “(See Note A-1.4.1.2.(1).)” at the end of the defined term “<i>Conditioned space</i>” in Sentence (1);  <hr/> </p> <p>Insert “glazed sections of curtain walls,” after “<i>skylights</i>,” in the defined term “<i>Fenestration</i>” in Sentence (1);  <hr/> </p> <p>Insert the following defined terms in alphabetical order:</p> <p>“<i>Effective thermal resistance</i> (RSI<sub>E</sub> value) means the inverse of the <i>overall thermal transmittance</i>. The RSI<sub>E</sub> value shall be calculated,</p> <p>(a) for <i>opaque building assemblies</i>, according to Sentence 3.1.1.5.(5) and Article 3.1.1.7., and</p> <p>(b) for opaque sections of curtain walls, according to Sentence 3.1.1.5.(6).”;</p> <p>“<i>Linear thermal transmittance</i> (<math>\Psi</math>) means the rate, in W/(m×K), at which heat is transferred per unit of length through a <i>building</i> assembly resulting from a steady-state temperature difference. (See Note A-1.4.1.2.(1).)”;  <hr/> </p> <p>“<i>Point thermal transmittance</i> (<math>\chi</math>) means the rate, in W/K, of heat transfer by point penetration through a <i>building</i> assembly that is subject to a steady-state temperature difference. (See Note A-1.4.1.2.(1).)”.  <hr/> </p>
--	--

	Strike out the following defined terms in Sentence (1):  “ <i>Gross lighted area</i> ”;  “ <i>Partition</i> ”.
1.4.2.1.	Insert the following symbols and other abbreviations in alphabetical order in Sentence (1):  “HDD..... heating degree-days under 18°C”; “ILE..... installed <i>interior lighting</i> energy”; “ILEA..... <i>interior lighting</i> energy allowance”.
<b>Division A Part 1 Schedule A</b>	
A-1.1.1.1.(2)	Strike out the Note.
	Add the following Note:  “ <b>A-1.1.1.2. Building Parameters.</b> The construction and design parameters used to establish compliance with this Code must represent the anticipated operating conditions of the building. The rentable areas that were not defined when preparing the plans and specifications and constructing the building are not exempted from the requirements of this Code.”.
A-1.2.1.1.(1)(b)	Replace ““alternative solution.”” in the Note concerning “ <b>Code Compliance via Alternative Solutions</b> ” by the following:  ““alternative solution” and be approved by the Régie du bâtiment du Québec according to the conditions it determines in accordance with section 127 of the Building Act (chapter B-1.1) or, in the case of buildings or equipment on which the Board has no jurisdiction, by the authority having jurisdiction.”;  Strike out the following at the end of the Note concerning “ <b>Code Compliance via Alternative Solutions</b> ”:  “, i.e. the consequence remaining once the applicable acceptable solutions in Division B have been implemented represents the residual consequence deemed to be acceptable by the broad base of Canadians who have taken part in the consensus process used to develop the Code”.
A-1.4.1.2.(1)	Insert the following after the Note concerning the defined term “ <b>Gross lighted area</b> ”:

**“Thermal Block**

Where multiple control zones have windows on more than one facade of the building, they may be considered a thermal block only under certain conditions. Grouping zones that have fenestration in a single thermal block is permitted only where the fenestration has a similar azimuth, that is, where the elements of fenestration have an azimuth that differs less than 45°. It is also possible that multiple azimuths of a same zone have an exterior fenestration, such as an office in the northeastern corner of an office tower. In that case, only one thermal block could be formed with all the offices of the intermediate stores of the northeastern corner.”;

Strike out the Note concerning the defined term **“Interior Lighting”**.

Add the following at the end of the Note concerning the defined term **“Overall Thermal Transmittance (U-value)”**:

“The unit of the Celsius temperature scale is the degree Celsius (symbol °C), which has the same magnitude as the Kelvin (abbreviation K). Kelvin units and degrees Celsius are equivalent and a temperature interval in degrees Celsius has the same numerical value as a temperature interval in Kelvin.”;

Insert the following after the Note concerning the defined term **“Overall Thermal Transmittance (U-value)”**:

**“Annual Energy Consumption**

Fuel consumption is generally calculated by the programs in terms of volume. In such a case, the consumption must be converted in terms of energy.

**Exterior Lighting**

Exterior lighting includes in particular lighting of exterior advertising signage and exterior parking areas.

**Linear Thermal Transmittance**

The coefficient makes it possible to express the influence of the linear thermal bridging over the total heat losses of part of the envelope of a building.

**Point Thermal Transmittance**

The coefficient makes it possible to express the influence of a point thermal bridging over the total heat losses of part of the envelope of a building.

Insert the following after the Note concerning the defined term **“Building Envelope Application”**:

**“Conditioned space**

The term “unconditioned space” is sometimes used in the NECB. Although that term is not defined in the NECB, where it is used in the NECB and its appended notes, its meaning is the opposite of the defined term “conditioned space”, namely: any space inside a building that is neither heated nor cooled.

	The same applies to the term “space-conditioning system”, which is not defined in the NECB. Where that term is used in the NECB and its appended notes, it refers to any heating or cooling system.”.
<b>Division B Part 1</b>	
<b>1.1.2.1.</b>	Replace Clauses (1)(a) to (1)(c) by the following: “a) the prescriptive or trade-off requirements stated in Parts 3 to 7, or b) the performance requirements stated in Part 8.”.
<b>1.1.4.2.</b>	Replace Clauses (1)(b) to (1)(d) by the following: “b) “HRAI Digest”, and c) Hydronics Institute Manuals.”.
<b>1.2.1.2.</b>	Strike out Sentence (2).
<b>1.3.1.2.</b>	Replace the documents concerned by the following in Table 1.3.1.2.: “AAMA 501.5-07 Test Method for Thermal Cycling of Exterior Walls 3.1.1.8.(3)”;  “AHRI 1061 (SI)-2013 Performance Rating of Air-to-Air Exchangers for Energy Recovery Ventilation Equipment 5.2.10.1.(5) 5.2.10.4.(2)(b)”;  “ASHRAE 2013 ASHRAE Handbook – Fundamentals 3.1.1.5.(4) A-3.1.1.5.(5)(a) A-3.1.1.5.(5)(b), (6)(c) and (7)(a)

	<p>A-3.3.1.3.(2) A-8.4.3.3.(7)”;</p> <p>“ASHRAE/IES 90.1-2013 User’s Manual 8.4.4.6.(4) A-6.2.3.1.(1) A-8.4.4.6.(4)”;</p> <p>“ASHRAE ANSI/ASHRAE 140-2011 Standard Method of Test for the Evaluation of Building Energy Analysis Computer Programs 8.4.2.2.(1) A-8.4.2.2.(1)”;</p> <p>“ASHRAE RP-1365-2011 Thermal Performance of Building Envelope Details for Mid- and High-Rise Buildings A-3.1.1.5.(5)(b), (6)(c) and (7)(a) A-3.3.1.3.(2)”;</p> <p>“ASTM C1363-11 Standard Test Method for Thermal Performance of Building Materials and Envelope Assemblies by Means of a Hot Box Apparatus 3.1.1.5.(4) 3.1.1.5.(5) 3.1.1.5.(7)”;</p> <p>“ASTM E283-04 Standard Test Method for Determining Rate of Air Leakage Through Exterior Windows, Curtain Walls, and Doors Under Specified Pressure Differences Across the Specimen 3.1.1.8.(3)</p>
--	---



<p>3.1.1.8.(4)”;</p> <p>“CCBFC NRCC-CONST-56435E National Building Code of Canada 2020 1.1.1.3.(1)<sup>(3)</sup> 1.1.1.3.(2)<sup>(3)</sup> 1.4.1.2.(1)<sup>(3)</sup> A-3.2.1.1.(1)<sup>(3)</sup> 3.1.1.5.(1) A-3.2.3.1.(3) 5.2.1.1.(1) 5.2.2.1.(1) 5.2.2.8.(2) 5.2.5.1.(1) 5.2.8.9.(4) 5.2.8.9.(5) 5.2.10.2.(2) A-5.2.2.8.(2) A-5.2.8.4.(1) A-5.2.10.4.(1) 8.4.3.6.(1) 8.4.4.17.(4) 8.4.4.17.(5)”;</p> <p>“CCBFC NRCC-CONST-56436E National Plumbing Code of Canada 2020 A-3.2.1.1.(1)<sup>(3)</sup> A-5.2.10.4.(1) 6.2.1.1.(1)”;</p> <p>“CSA AAMA/WDMA/CSA 101/I.S.2/A440-17 North American Fenestration Standard/Specification for Windows, Doors, and Skylights 3.1.1.8.(2)</p>
--

	<p>3.1.1.8.(4)”;</p> <p>“CSA CAN/CSA-A440.2-19/A440.3-19 Fenestration Energy Performance/User Guide to CSA A440.2-19, Fenestration Energy Performance 3.1.1.5.(3) 3.1.1.5.(6) A-3.1.1.6.(1)”;</p> <p>“CSA CAN/CSA-C439-09 Rating the Performance of Heat/Energy-Recovery Ventilators 5.2.10.1.(5)(b) 5.2.10.4.(2)(a) A-5.2.10.4.(2)(a)”;</p> <p>“HVI HVI Publication 911 Certified Home Ventilating Products Directory 5.2.10.4.(2)(a);</p> <p>“IES ANSI/IES RP-28-07 Lighting and the Visual Environment for Senior Living Table 4.2.1.6. Table 8.4.3.4.-A Table A-8.4.3.8.(1)-B”;</p> <p>“ISO 14683:2007 Thermal bridges in building construction – Linear thermal transmittance – Simplified methods and default values A-3.1.1.5.(5)(b), (6)(c) and (7)(a)”;</p> <p>“NFRC 100-2010</p>
--	--

<p>Procedure for Determining Fenestration Product U-factors 3.1.1.5.(3) 3.1.1.5.(6)”;</p> <p>“NRCan SOR/2016-311 Energy Efficiency Regulations, 2016 Table 5.2.12.1.-A Table 5.2.12.1.-B Table 5.2.12.1.-C Table 5.2.12.1.-D Table 5.2.12.1.-E Table 5.2.12.1.-G Table 5.2.12.1.-I Table 5.2.12.1.-K Table 5.2.12.1.-N Table 5.2.12.1.-O A-5.2.12.1.(1) and 6.2.2.1.(1) Table 6.2.2.1.”;</p> <p>“NRCan S.C. 1992, c. 36 Energy Efficiency Act A-5.2.12.1.(1) and 6.2.2.1.(1)”;</p> <p>“SMACNA ANSI/SMACNA 006-2006 HVAC Duct Construction Standards – Metal and Flexible 5.2.2.3.(1) A-5.2.2.1.(1) A-5.2.2.3.(1)”;</p> <p>“ULC CAN/ULC-S742-11 Standard for Air Barrier Assemblies – Specification 3.1.1.8.(1) A-3.1.1.8.(1)</p>
--

	<p>A-3.2.4.3.(1) and (2)”;</p> <hr/> <p>Insert the following documents in Table 1.3.1.2., in order of the organizations:</p> <p>“ASTM E2357-18 Standard Test Method for Determining Air Leakage of Air Barrier Assemblies 3.1.1.8.(1) A-3.1.1.8.(1)”;</p> <p>“CSA A440S1-19 Canadian supplement to AAMA/WDMA/CSA 101/I.S.2/A440-17, North American Fenestration Standard (NAFS)/Specification for Windows, Doors and Skylights 3.1.1.8.(2) 3.1.1.8.(4)”;</p> <p>“ISO 6946:2007 Building components and building elements – Thermal resistance and thermal transmittance – Calculation method A-3.1.1.5.(5)(a)”;</p> <p>“ISO 10211:2017 Thermal bridges in building construction – Heat flows and surface temperatures – Detailed calculations A-3.1.1.5.(5)(b), (6)(c) and (7)(a)”;</p> <p>“UL UL 181A-2013 Closure Systems for Use with Rigid Air Ducts 5.2.2.3.(5)”;</p> <p>“UL UL 181B-2013 Closure Systems for Use with Flexible Air Ducts and Air Connectors 5.2.2.3.(5)”;</p>
--	---

	<p>Strike out the following documents in Table 1.3.1.2.:</p> <p>“ASHRAE 2011 ASHRAE Handbook – HVAC Applications A-6.2.4.1.(1)”;</p> <p>“ASHRAE ANSI/ASHRAE 62.1-2016 Ventilation for Acceptable Indoor Air Quality A-5.2.3.4.(1)”;</p> <p>“ASHRAE ANSI/ASHRAE 84-2013 Method of Testing Air-to-Air Heat/Energy Exchangers 5.2.10.1.(5)”;</p> <p>“ASHRAE/IES ANSI/ASHRAE/IES 90.1-2013 Energy Standard for Buildings Except Low-Rise Residential Buildings A-Table 3.2.2.2. A-5.2.3.4.(2)”;</p>
--	---

<p>“ASME/CSA ASME A112.18.1-2018/CSA B125.1-18 Plumbing Supply Fittings 6.2.6.1.(1) 6.2.6.2.(1)”;</p> <p>“ASTM E779-10 Standard Test Method for Determining Air Leakage Rate by Fan Pressurization 8.4.2.9.(2)”;</p> <p>“ASTM E3158-18 Standard Test Method for Measuring the Air Leakage Rate of a Large or Multizone Building A-3.2.4.2.(1)”;</p> <p>“BC Hydro 2014 Building Envelope Thermal Bridging Guide A-3.1.1.5.(5)(a)”;</p> <p>“CSA C22.1-18 Canadian Electrical Code, Part I A-7.2.1.1.”;</p> <p>“CSA C390-10 Test Methods, Marking Requirements, and Energy Efficiency Levels for Three-Phase Induction Motors 7.2.4.1.(1)”;</p> <p>“CSA C802.1-13 Minimum Efficiency Values for Liquid-Filled Distribution Transformers 7.2.3.1.(1)”;</p>
--

	<p>“CSA C802.2-18 Test Method and Minimum Efficiency Values for Dry-Type Transformers 7.2.3.1.(1)”;</p> <p>“CSA CAN/CSA-C802.3-15 Minimum Efficiency Values for Power Transformers 7.2.3.1.(1)”;</p> <p>“CSA C828-13 Thermostats Used with Individual Room Electric Space Heating Devices 5.2.8.6.(4)”;</p> <p>“CSA C873.4-14 Building Energy Estimation Methodology – Part 4 – Energy Consumption for Lighting 4.3.1.3.(1) 4.3.1.3.(2) 4.3.1.3.(3) 4.3.1.3.(4) 4.3.1.3. 5)”;</p> <p>“DASMA ANSI/DASMA 105-2017 Test Method for Thermal Transmittance and Air Infiltration of Garage Doors 3.2.4.3.(8)”;</p> <p>“IES HB-10-11 The Lighting Handbook, 10th Edition A-Table 4.3.2.8.”;</p> <p>“ISO</p>
--	--

	<p>13790:2008 Energy performance of buildings - Calculation of energy use for space heating and cooling 1.1.4.2.(1);</p> <p>“TIAC 2013 Mechanical Insulation Best Practices Guide A-5.2.2.5.(8) and 5.2.5.3.(7)”;</p> <p>“ULC CAN/ULC-S741-08 Standard for Air Barrier Materials – Specification 3.2.4.3.(2)”.</p>
<b>1.3.2.1.</b>	<p>Insert the following abbreviations, in alphabetical order, in Sentence (1):</p> <p>“BRE            Building Research Establishment (<a href="http://www.bregroup.com">www.bregroup.com</a>)”;</p> <p>“UL             Underwriters Laboratory (<a href="http://www.ul.com">www.ul.com</a>)”.</p>

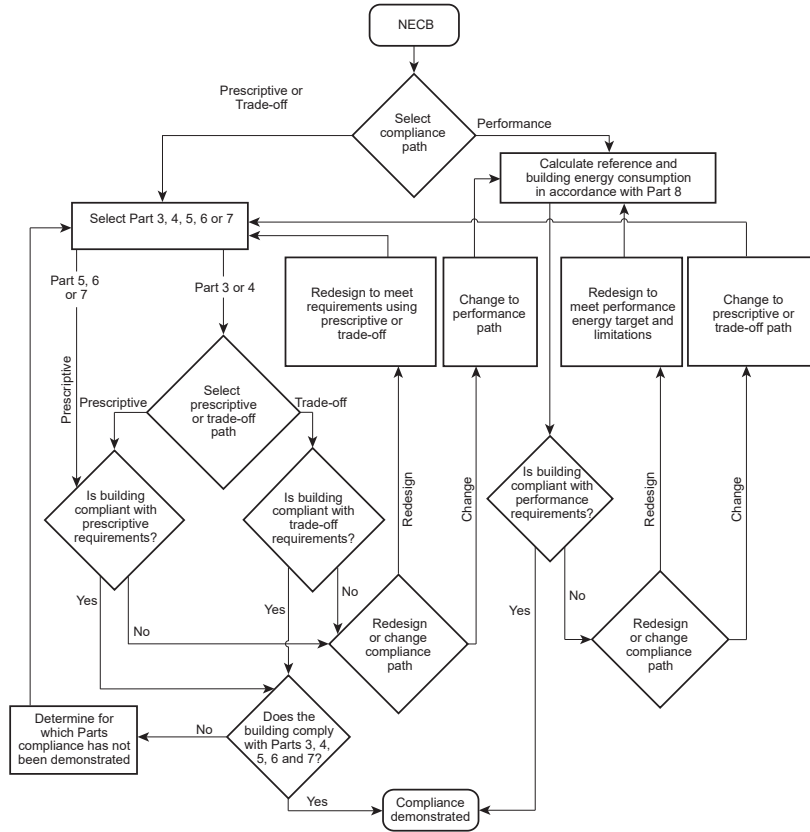


**Division B  
Part 1  
Schedule A**

Replace Figure A-1.1.2.1. by the following:

“

**A-1.1.2.1.**



**Figure A-1.1.2.1.  
Decision flow chart for Code compliance”;**

Strike out “and/or vary the fenestration and door area” after “more components of the building envelope” in the Note concerning “Trade-off Path”.

<p><b>Division B</b> <b>Part 3</b></p>	
<p><b>3.1.1.2.</b></p>	<p>Insert “(See Note A-3.1.1.2.(1)(b).)” at the end of Sentence (1)(b).</p>
<p><b>3.1.1.5.</b></p>	<p>Replace Sentence (5) by the following:</p> <p><b>5)</b> The <i>effective thermal resistance</i> characteristics of <i>building</i> assemblies other than <i>fenestration</i>, doors and opaque sections of curtain walls shall be determined in accordance with</p> <ul style="list-style-type: none"> <li>a) a simplified calculation method that takes into account the specific parameters of <i>building</i> assemblies, including <ul style="list-style-type: none"> <li>i) a discontinuity at the expanses of insulation, and</li> <li>ii) the thermal conductivity difference between the materials contributing to the discontinuity</li> </ul> <p>(see Note A-3.1.1.5.(5)(a)),</p> </li> <li>b) the heat transfer digital simulations (see Note A-3.1.1.5.(5)(b), (6)(c) and (7)(a)), or</li> <li>c) laboratory tests performed in accordance with ASTM C 1363, “Standard Test Method for Thermal Performance of Building Materials and Envelope Assemblies by Means of a Hot Box Apparatus,” using an indoor air temperature of <math>21\pm 1^{\circ}\text{C}</math> and an outdoor air temperature of <math>-18\pm 1^{\circ}\text{C}</math>.”</li> </ul> <p><b>6)</b> The <i>effective thermal resistance</i> of the opaque sections of curtain walls shall be determined in accordance with</p> <ul style="list-style-type: none"> <li>a) CAN/CSA-A440.2/A440.3, “Fenestration Energy Performance/User Guide to CSA A440.2-19, Fenestration Energy Performance,”</li> <li>b) NFRC 100, “Procedure for Determining Fenestration Product U-factors,” or</li> <li>c) the heat transfer digital simulations (see Note A-3.1.1.5.(5)(b), (6)(c) and (7)(a)).</li> </ul> <p><b>7)</b> The <i>linear thermal transmittance</i> and the <i>point thermal transmittance</i> shall be determined from</p> <ul style="list-style-type: none"> <li>a) the heat transfer digital simulations (see Note A-3.1.1.5.(5)(b), (6)(c) and (7)(a)), or</li> <li>b) laboratory tests performed in accordance with ASTM C 1363, “Standard Test Method for Thermal Performance of Building Materials and Envelope Assemblies by Means of a Hot Box Apparatus,” using an indoor air temperature of <math>21\pm 1^{\circ}\text{C}</math> and an outdoor air temperature of <math>-18\pm 1^{\circ}\text{C}</math>.”</li> </ul>
<p><b>3.1.1.6.</b></p>	<p>Replace the heading of the Article by the following:</p> <p><b>“3.1.1.6. Characteristics and Calculation of Surface Areas”;</b></p> <hr/> <p>Replace Sentences (3) and (4) by the following:</p>

	<p><b>3)</b> In the calculation of allowable door and <i>fenestration</i> area, excluding <i>skylight</i> areas, the gross wall area shall be calculated as the sum of the areas of all above-ground wall assemblies including <i>fenestration</i> and doors, but not including parapets, projected fins, ornamentation and appendages.</p> <p><b>4)</b> In the calculation of allowable door and <i>fenestration</i> area in <i>additions</i>, compliance shall be based on the <i>addition</i> considered independently.”;</p> <hr/> <p>Add the following Sentences:</p> <p><b>6)</b> <i>Opaque building assemblies</i> areas shall be calculated along the plane of the insulation using dimensions measured to the exterior walls of adjacent <i>building assemblies</i>, and include the area of the intersection surfaces of the interior <i>building assemblies</i>. (See Note A-3.1.1.6.(1).)</p> <p><b>7)</b> Wall assemblies inclined less than 60° from the horizontal shall be considered as roof assemblies, and roof assemblies inclined 60° or more from the horizontal shall be considered as wall assemblies.</p> <p><b>8)</b> <i>Fenestration</i> and door areas integrated to curtain walls shall be calculated from the axis of any mullion separating the <i>fenestration</i> or doors from the opaque sections of curtain walls.”.</p>
3.1.1.7.	<p>Replace the Article by the following:</p> <p><b>“3.1.1.7. Calculation of Effective Thermal Resistance</b></p> <p><b>1)</b> The calculation of the <i>effective thermal resistance</i> of <i>opaque building assemblies</i> shall account for the specific thermal resistance of</p> <ol style="list-style-type: none"> <li>a) continuous members, such as a concrete slab,</li> <li>b) repetitive structural members, such as studs and joists, jambs and resilient bars, and</li> <li>c) ancillary structural members, such as lintels, sills and plates.</li> </ol> <p>(See Note A-3.1.1.7.(1).)</p> <p><b>2)</b> In calculating the <i>effective thermal resistance</i> of <i>opaque building assemblies</i>, the thermal bridging effect of major structural members, such as columns and spandrel beams, that are parallel to the plane of the <i>building envelope</i> and partly penetrate that <i>building envelope</i> assembly need not be taken into account, provided they do not reduce the <i>effective thermal resistance</i> at the projected area at less than half the value required by Section 3.2. (See Note A-3.1.1.7.(2).)</p> <p><b>3)</b> In calculating the <i>effective thermal resistance</i> of <i>opaque building assemblies</i>, the following elements need not be taken into account when they must partially or completely penetrate the <i>building envelope</i> to perform their intended function and when they comply with the requirements of Article 3.2.1.2.:</p> <ol style="list-style-type: none"> <li>a) pipes,</li> <li>b) ducts,</li> <li>c) equipment with through-the-wall venting,</li> <li>d) equipment of an HVAC system,</li> <li>e) minor ties and anchors, and any other similar member, necessary to the structure of the envelope,</li> </ol>

	<p>f) linear anchoring devices, such as shelf angles for masonry, and</p> <p>g) major structural penetrations, such as balcony slabs, beams, girders, columns, ornamentation and appendages.</p> <p>(See Note A-3.1.1.7.(3).)</p> <p><b>4)</b> Where a component of the <i>building envelope</i> is protected by an unconditioned enclosed space, such as a sun porch, enclosed veranda or vestibule, the enclosure may be considered to have an <i>effective thermal resistance</i> of 0.16 m<sup>2</sup>·K/W. (See Note A-3.1.1.7.(4).)</p> <p><b>5)</b> In calculating the <i>effective thermal resistance</i> of an <i>opaque building assembly</i>, the effect of overlapping expanses of insulation, on either side of a <i>building assembly</i>, does not have to be taken into account where they comply with the requirements of Article 3.2.1.2.</p> <p><b>6)</b> In calculating the <i>effective thermal resistance</i> of an <i>opaque building assembly</i>, the effect of the transitions between the constructive systems of the <i>building envelope</i>, such as joints between walls and <i>fenestration</i>, does not have to be taken into account where they comply with the requirements of Article 3.2.1.2.</p> <p><b>7)</b> For the purposes of this Article, wall assemblies shall be considered to include all related structural framing and perimeter areas of intersecting interior walls.</p> <p><b>8)</b> For the purposes of this Article, floor assemblies shall be considered to include all related structural framing.</p> <p><b>9)</b> For the purposes of this Article, roof assemblies shall be considered to include all related structural framing.”.</p>
	<p>Add the following Article:</p> <p><b>“3.1.1.8. Air Leakage in Building Assemblies</b></p> <p><b>1)</b> <i>Air barrier assemblies</i> in <i>opaque building assemblies</i> excluding the opaque sections of curtain walls shall be assessed in accordance with</p> <p>a) CAN/ULC-S742, “Standard for Air Barrier Assemblies – Specification,” or</p> <p>b) ASTM E 2357, “Standard Test Method for Determining Air Leakage of Air Barrier Assemblies,” provided that</p> <p>i) the <i>building</i> is erected in an area where it will not be submitted to extended wind pressures having a probability of 1 out of 50 to be exceeded during one year by more than 0.65 kPa, and</p> <p>ii) the <i>air barrier assembly</i> is installed on the warm side of the thermal insulation of the <i>opaque building assembly</i>.</p> <p>(See Note A-3.1.1.8.(1).)</p> <p><b>2)</b> The air leakage rates of the <i>fenestration</i> excluding the glazed sections of curtain walls shall be assessed in accordance with</p> <p>a) AAMA/WDMA/CSA 101/I.S.2/A440-11, “NAFS – North American Fenestration Standard/Specification for windows, doors, and skylights,” and</p> <p>b) CSA A440S1, “Canadian Supplement to AAMA/WDMA/CSA 101/I.S.2/A440-17, NAFS – North American Fenestration Standard/Specification for windows, doors, and skylights.”</p>

	<p><b>3)</b> Air leakage rates of curtain walls forming part of the <i>building envelope</i> shall be assessed in accordance with ASTM E 283, “Standard Test Method for Determining Rate of Air Leakage Through Exterior Windows, Curtain Walls, and Doors Under Specified Pressure Differences Across the Specimen,” when the specimen is prepared in accordance with Clause 6 of AAMA 501.5, “Test Method for Thermal Cycling of Exterior Walls.”</p> <p><b>4)</b> Air leakage rates of doors forming part of the <i>building envelope</i> shall be assessed in accordance with</p> <p>a) ASTM E 283, “Standard Test Method for Determining Rate of Air Leakage Through Exterior Windows, Curtain Walls, and Doors Under Specified Pressure Differences Across the Specimen,” or</p> <p>b) the following standards:</p> <p>i) AAMA/WDMA/CSA 101/I.S.2/A440, “NAFS – North American Fenestration Standard/Specification for windows, doors, and skylights,” and</p> <p>ii) CSA A440S1, “Canadian Supplement to AAMA/WDMA/CSA 101/I.S.2/A440-17, NAFS – North American Fenestration Standard/Specification for windows, doors, and skylights.””.</p>
3.2.1.1.	<p>Replace “increasing the <i>overall thermal transmittance</i>” in Sentence (1) by “reducing the thermal resistance”.</p> <hr/> <p>Replace “the <i>overall thermal transmittance</i>” in Sentence (2) by “the thermal resistance”.</p>
3.2.1.2.	<p>Replace the Article by the following:</p> <p><b>“3.2.1.2. Continuity of Insulation</b></p> <p><b>1)</b> Except as provided in Sentences (2) to (7) and (9), interior <i>building</i> assemblies, including wall assemblies and major structural members that are embedded along exterior walls that partly penetrate the <i>building envelope</i></p> <p>a) shall not break the continuity of the insulation, and</p> <p>b) shall have an <i>effective thermal resistance</i> at their projected area equal to at least the resistance required for the <i>building envelope</i>.</p> <p>(See Note A-3.2.1.2.(1).)</p> <p><b>2)</b> The following members need not be taken into account to comply with Sentence (1):</p> <p>a) repetitive structural members, such as studs and joists, jambs and resilient bars,</p> <p>b) ancillary structural members, such as lintels, sills and plates, and</p> <p>c) minor penetrations of the envelope, such as ties.</p> <p>(See Note A-3.2.1.2.(2).)</p> <p><b>3)</b> Except as provided in Sentences (4), (9) and (10), where an interior wall, <i>foundation</i> wall, <i>firewall</i>, party wall, structural member, ornamentation or</p>

	<p>appendage penetrates the <i>building envelope</i> and breaks the continuity of its insulation, it shall</p> <p>a) be insulated</p> <p style="padding-left: 20px;">i) on its faces exposed to air inward or outward from the <i>building envelope</i> for a distance equal to 4 times its uninsulated thickness, and</p> <p style="padding-left: 20px;">ii) so that the <i>effective thermal resistance</i> of the penetrating member is not, for the distance prescribed by Subclause (i), less than that required for the penetrated component, or</p> <p>b) be insulated in continuity with the insulation of the penetrated component so that the <i>effective thermal resistance</i> at that location is equal to at least half the resistance required for the penetrated component.</p> <p>(See Note A-3.2.1.2.(3).)</p> <p><b>4)</b> Where a structural slab penetrates the <i>building envelope</i> and breaks the continuity of the insulation, the slab shall be insulated</p> <p>a) in accordance with the requirements of Sentence (3), or</p> <p>b) with materials having a thermal resistance of at least</p> <p style="padding-left: 20px;">i) 1.76 m<sup>2</sup>×K/W installed on the axis of the expanse of insulation of the penetrated wall for a distance of at least 2/3 of the penetration area, and</p> <p style="padding-left: 20px;">ii) 0.09 m<sup>2</sup>×K/W installed above and under the slab inward for a distance equal to at least 4 times the thickness of the slab.</p> <p>(See Note A-3.2.1.2.(4).)</p> <p><b>5)</b> Linear anchoring devices, shelf angles for masonry and other similar devices that penetrate the insulation of a component of the <i>building envelope</i> shall include intermittent transverse supports so that only the latter penetrate the insulation. (See Note A-3.2.1.2.(5).)</p> <p><b>6)</b> Joints between <i>building</i> assemblies of the <i>building envelope</i>, such as expansion or construction joints and joints between walls and doors or <i>fenestration</i>, shall be insulated</p> <p>a) in a manner that provides continuity of insulation across such joints, and</p> <p>b) in a manner that the <i>effective thermal resistance</i> at the location of those joints is equal to at least half of the lowest of the values required for the contiguous <i>building</i> assemblies.</p> <p>(See Note A-3.2.1.2.(6).)</p> <p><b>7)</b> Except as provided in Clause (9)(e), where 2 expanses of insulation are separated by a member of the <i>building envelope</i> and do not intersect, those expanses of insulation shall overlap for a distance equal to at least 4 times the thickness of the assembly separating them. (See Note A-3.2.1.2.(7).)</p> <p><b>8)</b> To comply with Sentence (7), hollow-core masonry walls shall be filled with grout, mortar or insulation at the location coinciding with the limits of the overlapped expanses of insulation. (See Note A-3.2.1.2.(8).)</p> <p><b>9)</b> The continuity of the insulation may be broken</p> <p>a) between a <i>foundation</i> wall and a floor slab in contact with the ground where the <i>foundation</i> wall is insulated from the exterior,</p>
--	--

	<p>b) the horizontal part of a <i>foundation</i> wall supporting an exterior screen-wall where it is insulated from the exterior,</p> <p>c) at minor transitions between the constructive systems of the <i>building envelope</i> that must break the continuity of the insulation to perform their intended function, such as backing necessary for fastening flashing at the intersection of parapets and roofs (see Note A-3.2.1.2.(9)(c)),</p> <p>d) where ducts or devices penetrate expanses of insulation of the <i>building envelope</i>, provided that the insulation is installed to follow closely the perimeter of those elements, or</p> <p>e) where the 2 expanses of insulation may not be extended for the distance required by Sentence (7), provided that the <i>effective thermal resistance</i> of the member of the <i>building envelope</i> that makes contact between the two insulation layers is equal to at least half the minimum value required.</p> <p><b>10)</b> A thermal bridging breaker part of a point penetration of the <i>building envelope</i> need not be insulated in accordance with the requirements of Sentence (3) where all the components of the point penetration have a <i>point thermal transmittance</i> of not more than 0.5 W/K.”.</p>
3.2.1.3.	<p>Replace the Article by the following:</p> <p><b>“3.2.1.3. Spaces Conditioned to Different Temperatures</b></p> <p><b>1)</b> The <i>effective thermal resistance</i>, <math>RSI_{E1}</math>, in <math>m^2 \times K/W</math>, of <i>building</i> assemblies separating <i>conditioned spaces</i> that are intended to be heated or cooled to temperatures that differ by more than 10°C shall be equal to at least the value obtained with the following equation:</p> $RSI_{E1} = [(t_2 - t_1) \cdot RSI_E] / 43$ <p>where</p> <p><math>t_2</math> = indoor design temperature of the warmer <i>conditioned space</i>, in °C,</p> <p><math>t_1</math> = indoor design temperature of the colder <i>conditioned space</i>, in °C, and</p> <p><math>RSI_E</math> = <i>effective thermal resistance</i> of 3.60 <math>m^2 \times K/W</math> for a wall and 5.46 <math>m^2 \times K/W</math> for a floor.</p> <p>(See Note A-3.2.1.3.(1).)</p> <p><b>2)</b> The <i>building</i> assemblies covered in Articles 3.2.2.2., 3.2.2.3., 3.2.2.4. and 3.2.3.1. insulating a heated but not cooled space whose heating setpoint is less than 18°C, shall have an <i>effective thermal resistance</i>, <math>RSI_{E1}</math>, in <math>m^2 \times K/W</math>, equal to at least the value obtained with the following equation:</p> $RSI_{E1} = [(t_1 - t_0) \cdot RSI_E] / (18 - t_0)$ <p>where</p> <p><math>t_1</math> = heating setpoint in winter months, in °C,</p> <p><math>t_0</math> = outdoor 2.5% January heating design temperature according to the location of the <i>building</i> determined in accordance with Sentence 1.1.4.1.(1), in °C, and</p> <p><math>RSI_E</math> = <i>effective thermal resistance</i> required in Tables 3.2.2.2., 3.2.2.3., 3.2.2.4. and 3.2.3.1., in <math>m^2 \times K/W</math>.</p> <p>(See Note A-3.2.1.3.(2).)”.</p>

3.2.1.4.	<p>Replace the Article by the following:</p> <p><b>“3.2.1.4. Allowable Fenestration and Door Area</b></p> <p>1) The total area of doors and <i>fenestration</i>, excluding the <i>skylight</i> area, shall correspond to not more than 40% of the gross wall area determined in accordance with Article 3.1.1.6.</p> <p>2) The total <i>skylight</i> area shall correspond to not more than 3% of the gross roof area as determined in Article 3.1.1.6.”.</p>																																									
3.2.2.1.	<p>Replace Clauses (3)(e) to (3)(g) by the following:</p> <p>“e) opens directly from a <i>dwelling unit</i>, or</p> <p>f) opens directly from a retail space less than 200 m<sup>2</sup> in <i>floor surface area</i> or from a space less than 150 m<sup>2</sup> in <i>floor surface area</i> for other uses.”.</p>																																									
3.2.2.2.	<p>Replace the Article by the following:</p> <p><b>“3.2.2.2. Thermal Characteristics of Above-ground Opaque Building Assemblies</b></p> <p>1) Except as provided in Sentences (2), (4), (5) and (6) and Article 3.2.1.3., the <i>effective thermal resistance</i> of above-ground <i>opaque building assemblies</i> shall be equal to at least that shown in Table 3.2.2.2. for the <i>building</i> or part thereof enclosed by the <i>opaque building assembly</i>, for the applicable heating-degree-day category taken at 18°C. (See Note A-3.2.2.2.(1).)</p> <p style="text-align: center;"><b>Table 3.2.2.2.</b> <b>Effective Thermal Resistance of Above-ground Opaque Building Assemblies</b> Forming Part of Sentences 3.2.2.2.(1), (5) and (6)</p> <table border="1" data-bbox="368 996 1183 1324"> <thead> <tr> <th rowspan="2" style="text-align: center;">Above-ground Opaque Building Assembly</th> <th colspan="6" style="text-align: center;">Heating Degree-Days under 18°C of <i>Building Location</i>,<sup>(1)</sup> in Celsius Degree-Days</th> </tr> <tr> <th style="text-align: center;">Zone 4: &lt; 3000</th> <th style="text-align: center;">Zone 5: 3000 to 3999</th> <th style="text-align: center;">Zone 6: 4000 to 4999</th> <th style="text-align: center;">Zone 7A: 5000 to 5999</th> <th style="text-align: center;">Zone 7B: 6000 to 6999</th> <th style="text-align: center;">Zone 8: ≥ 7000</th> </tr> </thead> <tbody> <tr> <td></td> <td colspan="6" style="text-align: center;">Minimum <i>Effective Thermal Resistance</i>, RSI<sub>E</sub>, in m<sup>2</sup>×K/W</td> </tr> <tr> <td style="text-align: center;">Walls</td> <td style="text-align: center;">3.60</td> <td style="text-align: center;">3.60</td> <td style="text-align: center;">3.60</td> <td style="text-align: center;">3.60</td> <td style="text-align: center;">4.05</td> <td style="text-align: center;">4.05</td> </tr> <tr> <td style="text-align: center;">Roofs</td> <td style="text-align: center;">5.46</td> <td style="text-align: center;">5.46</td> <td style="text-align: center;">5.46</td> <td style="text-align: center;">5.46</td> <td style="text-align: center;">6.17</td> <td style="text-align: center;">6.17</td> </tr> <tr> <td style="text-align: center;">Floors</td> <td style="text-align: center;">5.46</td> <td style="text-align: center;">5.46</td> <td style="text-align: center;">5.46</td> <td style="text-align: center;">5.46</td> <td style="text-align: center;">6.17</td> <td style="text-align: center;">6.17</td> </tr> </tbody> </table> <p><b>Notes to Table 3.2.2.2.:</b></p> <p>(1) See Sentence 1.1.4.1.(1).</p> <p>2) The <i>effective thermal resistance</i> of portions of a <i>foundation</i> wall that are above ground of which less than 50% of the area is exposed to exterior air shall be equal to at least that shown in Table 3.2.3.1. for walls in contact with the ground. (See Note A-3.2.2.2.(2) and (3).)</p> <p>3) The percentage of <i>foundation</i> walls that are above ground described in Sentence (2) shall be assessed independently for</p> <p>a) each of the walls,</p>	Above-ground Opaque Building Assembly	Heating Degree-Days under 18°C of <i>Building Location</i> , <sup>(1)</sup> in Celsius Degree-Days						Zone 4: < 3000	Zone 5: 3000 to 3999	Zone 6: 4000 to 4999	Zone 7A: 5000 to 5999	Zone 7B: 6000 to 6999	Zone 8: ≥ 7000		Minimum <i>Effective Thermal Resistance</i> , RSI <sub>E</sub> , in m <sup>2</sup> ×K/W						Walls	3.60	3.60	3.60	3.60	4.05	4.05	Roofs	5.46	5.46	5.46	5.46	6.17	6.17	Floors	5.46	5.46	5.46	5.46	6.17	6.17
Above-ground Opaque Building Assembly	Heating Degree-Days under 18°C of <i>Building Location</i> , <sup>(1)</sup> in Celsius Degree-Days																																									
	Zone 4: < 3000	Zone 5: 3000 to 3999	Zone 6: 4000 to 4999	Zone 7A: 5000 to 5999	Zone 7B: 6000 to 6999	Zone 8: ≥ 7000																																				
	Minimum <i>Effective Thermal Resistance</i> , RSI <sub>E</sub> , in m <sup>2</sup> ×K/W																																									
Walls	3.60	3.60	3.60	3.60	4.05	4.05																																				
Roofs	5.46	5.46	5.46	5.46	6.17	6.17																																				
Floors	5.46	5.46	5.46	5.46	6.17	6.17																																				



	<p>b) each of the <i>storeys</i>, and</p> <p>c) each constructive system.</p> <p>(See Note A-3.2.2.2.(2) and (3).)</p> <p><b>4)</b> Where radiant heating cables or heating or cooling pipes or membranes are integrated to above-ground <i>opaque building assemblies</i>, the minimum <i>effective thermal resistance</i> provided for in Sentence (1) for the <i>opaque building assemblies</i> shall be increased by 25%. (See Note A-3.2.2.2.(4).)</p> <p><b>5)</b> The <i>effective thermal resistance</i> required for a flat roof may be reduced by not more than 20% at its lowest point when drainage slopes are created by the insulation materials, provided that the value of the average <i>effective thermal resistance</i> for the roof is at least equal to the value shown in Table 3.2.2.2 for a roof. (See Note A-3.2.2.2.(5).)</p> <p><b>6)</b> The <i>effective thermal resistance</i> required for a roof with an attic space may be reduced for a distance of not more than 1200 mm measured from the outside face of the wall when the slope of the roof with an attic space and the necessary clearance for the ventilation so require, provided that it is equal to at least the value shown in Table 3.2.2.2. for an above-ground wall. (See Note A-3.2.2.2.(6).)”.</p>																																	
3.2.2.3.	<p>Replace “Sentences (3) and 3.2.1.3.(1)” in Sentence (2) by “Article 3.2.1.3.”;</p> <hr/> <p>Replace Sentence (3) by the following:</p> <p><b>“3)</b> The <i>overall thermal transmittance of fenestration</i> shown in Table 3.2.2.3. shall be reduced by at least 10% in the case of an <i>addition</i></p> <p>a) whose <i>floor surface area</i> is not more than 200 m<sup>2</sup>, and</p> <p>b) whose opening percentage exceeds the values prescribed in Sentence 3.2.1.4.(1).”;</p> <hr/> <p>Replace Table 3.2.2.3. by the following:</p> <p style="text-align: center;"><b>“Table 3.2.2.3.</b> <b>Overall Thermal Transmittance of Fenestration</b> Forming Part of Sentences 3.2.2.3.(2) and (3)</p> <table border="1" data-bbox="438 1229 1256 1551"> <thead> <tr> <th rowspan="3">Component</th> <th colspan="6">Heating Degree-Days under 18°C of <i>Building Location</i>,<sup>(1)</sup> in Celsius Degree-Days</th> </tr> <tr> <th>Zone 4: &lt; 3000</th> <th>Zone 5: 3000 to 3999</th> <th>Zone 6: 4000 to 4999</th> <th>Zone 7A: 5000 to 5999</th> <th>Zone 7B: 6000 to 6999</th> <th>Zone 8: ≥ 7000</th> </tr> <tr> <th colspan="6">Maximum Overall Thermal Transmittance, in W/(m<sup>2</sup>×K)</th> </tr> </thead> <tbody> <tr> <td><i>Fenestration</i> except <i>skylights</i></td> <td>2.00</td> <td>2.00</td> <td>2.00</td> <td>2.00</td> <td>1.60</td> <td>1.60</td> </tr> <tr> <td><i>Skylights</i></td> <td>2.85</td> <td>2.85</td> <td>2.85</td> <td>2.85</td> <td>2.70</td> <td>2.70</td> </tr> </tbody> </table> <p><b>Notes to Table 3.2.2.3.:</b></p> <p><sup>(1)</sup> See Sentence 1.1.4.1.(1).”.</p>	Component	Heating Degree-Days under 18°C of <i>Building Location</i> , <sup>(1)</sup> in Celsius Degree-Days						Zone 4: < 3000	Zone 5: 3000 to 3999	Zone 6: 4000 to 4999	Zone 7A: 5000 to 5999	Zone 7B: 6000 to 6999	Zone 8: ≥ 7000	Maximum Overall Thermal Transmittance, in W/(m <sup>2</sup> ×K)						<i>Fenestration</i> except <i>skylights</i>	2.00	2.00	2.00	2.00	1.60	1.60	<i>Skylights</i>	2.85	2.85	2.85	2.85	2.70	2.70
Component	Heating Degree-Days under 18°C of <i>Building Location</i> , <sup>(1)</sup> in Celsius Degree-Days																																	
	Zone 4: < 3000		Zone 5: 3000 to 3999	Zone 6: 4000 to 4999	Zone 7A: 5000 to 5999	Zone 7B: 6000 to 6999	Zone 8: ≥ 7000																											
	Maximum Overall Thermal Transmittance, in W/(m <sup>2</sup> ×K)																																	
<i>Fenestration</i> except <i>skylights</i>	2.00	2.00	2.00	2.00	1.60	1.60																												
<i>Skylights</i>	2.85	2.85	2.85	2.85	2.70	2.70																												

	<p>Replace “Except as provided in Sentences (2), (3), (5) and 3.2.1.3.(1)” in Sentence (1) by “Except as provided in Sentences (2) to (5) and Article 3.2.1.3.”;</p> <hr/> <p>Replace Sentences (2) and (3) by the following:</p> <p>“<b>2)</b> Except as provided in Sentences (3) and (5), the <i>overall thermal transmittance</i> of doors shown in Table 3.2.2.4. shall be reduced by at least 10% in the case of an <i>addition</i></p> <p>a) whose <i>floor surface area</i> is not more than 200 m<sup>2</sup>, and</p> <p>b) whose opening percentage exceeds the values prescribed in Sentence 3.2.1.4.(1).</p> <p><b>3)</b> The following doors need not comply with Sentence (1) or (2) where their total area is not more than 2% of the gross wall area calculated in accordance with Article 3.1.1.6.:</p> <p>a) automatic sliding glass doors,</p> <p>b) revolving doors,</p> <p>c) fire shutters, and</p> <p>d) other types of doors having an <i>overall thermal transmittance</i> of not more than 4.4 W/(m<sup>2</sup>×K).”;</p> <hr/> <p><b>3.2.2.4.</b> Replace Table 3.2.2.4. by the following:</p> <p style="text-align: center;"><b>“Table 3.2.2.4.</b> <b>Overall Thermal Transmittance of Doors</b> Forming Part of Sentences 3.2.2.4.(1) and (2)</p> <table border="1" data-bbox="365 964 1183 1304"> <thead> <tr> <th rowspan="3">Component</th> <th colspan="6">Heating Degree-Days under 18°C of <i>Building Location</i>,<sup>(1)</sup> in Celsius Degree-Days</th> </tr> <tr> <th>Zone 4: &lt; 3000</th> <th>Zone 5: 3000 to 3999</th> <th>Zone 6: 4000 to 4999</th> <th>Zone 7A: 5000 to 5999</th> <th>Zone 7B: 6000 to 6999</th> <th>Zone 8: ≥ 7000</th> </tr> <tr> <th colspan="6">Maximum <i>Overall Thermal Transmittance</i>, in W/(m<sup>2</sup>×K)</th> </tr> </thead> <tbody> <tr> <td>Glazed doors</td> <td>2.00</td> <td>2.00</td> <td>2.00</td> <td>2.00</td> <td>1.60</td> <td>1.60</td> </tr> <tr> <td>Doors without glazing</td> <td>0.90</td> <td>0.90</td> <td>0.90</td> <td>0.90</td> <td>0.80</td> <td>0.80</td> </tr> </tbody> </table> <p><b>Notes to Table 3.2.2.4.:</b></p> <p><sup>(1)</sup> See Sentence 1.1.4.1.(1).”;</p> <hr/> <p>Replace Sentence (5) by the following:</p> <p>“<b>5)</b> Storm doors need not comply with Sentence (1) or (2).”.</p>	Component	Heating Degree-Days under 18°C of <i>Building Location</i> , <sup>(1)</sup> in Celsius Degree-Days						Zone 4: < 3000	Zone 5: 3000 to 3999	Zone 6: 4000 to 4999	Zone 7A: 5000 to 5999	Zone 7B: 6000 to 6999	Zone 8: ≥ 7000	Maximum <i>Overall Thermal Transmittance</i> , in W/(m <sup>2</sup> ×K)						Glazed doors	2.00	2.00	2.00	2.00	1.60	1.60	Doors without glazing	0.90	0.90	0.90	0.90	0.80	0.80
Component	Heating Degree-Days under 18°C of <i>Building Location</i> , <sup>(1)</sup> in Celsius Degree-Days																																	
	Zone 4: < 3000		Zone 5: 3000 to 3999	Zone 6: 4000 to 4999	Zone 7A: 5000 to 5999	Zone 7B: 6000 to 6999	Zone 8: ≥ 7000																											
	Maximum <i>Overall Thermal Transmittance</i> , in W/(m <sup>2</sup> ×K)																																	
Glazed doors	2.00	2.00	2.00	2.00	1.60	1.60																												
Doors without glazing	0.90	0.90	0.90	0.90	0.80	0.80																												
<b>3.2.3.1.</b>	Replace Sentence (1) by the following:																																	

	<p>“1) Except as provided in Sentence (2) and Article 3.2.1.3., the <i>effective thermal resistance</i> of walls or portions thereof that are below the exterior ground level and are part of the <i>building envelope</i> shall not be less than that shown in Table 3.2.3.1. for the applicable heating-degree-day category taken at 18°C.</p> <p style="text-align: center;"><b>Table 3.2.3.1.</b> <b>Effective Thermal Resistance of Building Assemblies in Contact with the Ground</b> Forming Part of Sentences 3.2.2.2.(2), 3.2.3.1.(1) and 3.2.3.2.(1)</p> <table border="1" data-bbox="430 390 1249 672"> <thead> <tr> <th rowspan="3">Assembly in Contact with the Ground</th> <th colspan="6">Heating Degree-Days under 18°C of <i>Building Location</i>,<sup>(1)</sup> in Celsius Degree-Days</th> </tr> <tr> <th>Zone 4: &lt; 3000</th> <th>Zone 5: 3000 to 3999</th> <th>Zone 6: 4000 to 4999</th> <th>Zone 7A: 5000 to 5999</th> <th>Zone 7B: 6000 to 6999</th> <th>Zone 8: ≥ 7000</th> </tr> <tr> <th colspan="6">Minimum <i>Effective Thermal Resistance</i>, RSI<sub>E</sub>, in m<sup>2</sup>·K/W</th> </tr> </thead> <tbody> <tr> <td>Walls</td> <td>2.64</td> <td>2.64</td> <td>2.64</td> <td>2.64</td> <td>2.64</td> <td>2.64</td> </tr> <tr> <td>Roofs</td> <td>2.64</td> <td>2.64</td> <td>2.64</td> <td>2.64</td> <td>2.64</td> <td>2.64</td> </tr> </tbody> </table> <p><b>Notes to Table 3.2.3.1.:</b> <sup>(1)</sup> See Sentence 1.1.4.1.(1).</p> <hr/> <p>Strike out Sentence (2);</p> <hr/> <p>Replace “the wall shall have an <i>overall thermal transmittance</i> no greater than 80% of that required by Sentence (1)” in Sentence (4) by “the minimum <i>effective thermal resistance</i> provided for in Sentence (1) shall be increased by at least 25%”;</p> <hr/> <p>Replace Sentence (5) by the following: “5) The <i>effective thermal resistance</i> of the vertical portion of a slab-on-ground shall be the same as that required for walls in contact with the ground over the full height of the slab. (See Note A-3.2.3.1.(5)).”.</p>	Assembly in Contact with the Ground	Heating Degree-Days under 18°C of <i>Building Location</i> , <sup>(1)</sup> in Celsius Degree-Days						Zone 4: < 3000	Zone 5: 3000 to 3999	Zone 6: 4000 to 4999	Zone 7A: 5000 to 5999	Zone 7B: 6000 to 6999	Zone 8: ≥ 7000	Minimum <i>Effective Thermal Resistance</i> , RSI <sub>E</sub> , in m <sup>2</sup> ·K/W						Walls	2.64	2.64	2.64	2.64	2.64	2.64	Roofs	2.64	2.64	2.64	2.64	2.64	2.64
Assembly in Contact with the Ground	Heating Degree-Days under 18°C of <i>Building Location</i> , <sup>(1)</sup> in Celsius Degree-Days																																	
	Zone 4: < 3000		Zone 5: 3000 to 3999	Zone 6: 4000 to 4999	Zone 7A: 5000 to 5999	Zone 7B: 6000 to 6999	Zone 8: ≥ 7000																											
	Minimum <i>Effective Thermal Resistance</i> , RSI <sub>E</sub> , in m <sup>2</sup> ·K/W																																	
Walls	2.64	2.64	2.64	2.64	2.64	2.64																												
Roofs	2.64	2.64	2.64	2.64	2.64	2.64																												
3.2.3.2.	<p>Replace Sentence (1) by the following: “1) The <i>effective thermal resistance</i> of roofs in contact with the ground that are part of the <i>building envelope</i> and are less than 2.4 m below the exterior ground level shall be equal to at least the values shown in Table 3.2.3.1. for the heating-degree-day category taken at 18°C. (See Note A-3.2.3.2.(1)).”;</p> <hr/> <p>Strike out Sentence (2).</p>																																	
3.2.3.3.	<p>Replace the Article by the following: “3.2.3.3. <b>Thermal Characteristics of Floors in Contact with the Ground</b> (See Note A-3.2.3.3.)</p>																																	

1) For the purposes of this Article, “floor” also means the unfinished surface of a crawl space, where it is *conditioned space*.

2) Floors separating *conditioned space* from the ground shall be insulated with material having a thermal resistance equal to at least the values shown in in Table 3.2.3.3.-A or 3.2.3.3.-B, as the case may be.

**Table 3.2.3.3.-A**  
**Insulation of Floors in Contact with the Ground for any Occupancy except Dwelling Units**  
Forming Part of Sentences 3.2.3.3.(2) and (3)

Floors	Insulation Material	Intersection of the <i>Foundation</i> Wall with the Floor-on-ground
	Minimum Thermal Resistance, RSI, in m <sup>2</sup> ×K/W	
Floors of a slab-on-ground that does not have integrated heating ducts or cables or heating or cooling pipes	1.76 installed at the perimeter of the floor over a width of 1.2 m	n/a
Floors less than 0.6 m under contiguous ground level that does not have integrated heating ducts or cables or heating or cooling pipes	0.88 installed over the full area or 1.32 installed at the perimeter of the floor-on-ground over a width of at least 1.2 m	0.88
Floors-on-ground that have integrated heating ducts or cables or heating or cooling pipes	1.76 installed over the full area	1.32
Floors of a slab-on-ground that have integrated heating ducts or cables or heating or cooling pipes		n/a

**Table 3.2.3.3.-B**  
**Insulation of Floors in Contact with the Ground for Dwelling Units**  
Forming Part of Sentences 3.2.3.3.(2) and (3)

Floors	Insulation Material	Intersection of the <i>Foundation</i> Wall with the Floor-on-ground
	Minimum Thermal Resistance, RSI, in m <sup>2</sup> ×K/W	
Floors of a slab-on-ground that does not have integrated heating ducts or cables or heating or cooling pipes	1.32 installed over the full area	n/a
Floors at not more than 0.6 m under contiguous ground level that do not have integrated heating ducts or cables or heating or cooling pipes		1.32
Floors at more than 0.6 m under contiguous ground level that do not have integrated heating ducts or cables or heating or cooling pipes	0.88 installed over the full area, or 1.32 installed at the perimeter of the floor-on-ground over a width of at least 1.2 m	0.7
Floors of a slab-on-ground that have integrated heating ducts or cables or heating or cooling pipes	1.76 installed over the full area	n/a

	<table border="1" data-bbox="430 184 1249 270"> <tr> <td data-bbox="430 184 703 270">Floors-on-ground that have integrated heating ducts or cables or heating or cooling pipes</td> <td data-bbox="703 184 975 270"></td> <td data-bbox="975 184 1249 270">1.32</td> </tr> </table> <p data-bbox="430 283 1268 363"><b>3)</b> The thermal resistance of the insulation material between the <i>foundation</i> wall and the floor-on-ground shall be equal to at least the values shown in Table 3.2.3.3.-A or 3.2.3.3.-B, except</p> <p data-bbox="430 378 1268 458">a) where the insulation is installed on the exterior of the <i>foundation</i> wall and extends at least 2.4 m down from ground level or to the lower portion of the wall, or</p> <p data-bbox="430 473 1268 525">b) where the <i>foundation</i> wall and the floor slab are insulated from the inside and the insulation between the wall and the slab is continuous.”.</p>	Floors-on-ground that have integrated heating ducts or cables or heating or cooling pipes		1.32
Floors-on-ground that have integrated heating ducts or cables or heating or cooling pipes		1.32		
<b>3.2.4.1.</b>	Replace the portion after “by complying with” in Sentence (1) by “Article 3.2.4.3.”.			
<b>3.2.4.2.</b>	Strike out the Article.			
<b>3.2.4.3.</b>	<p data-bbox="430 775 904 802">Replace Sentences (1) to (9) by the following:</p> <p data-bbox="430 817 1268 892"><b>1)</b> <i>Air barrier assemblies</i> shall have an air leakage rate not greater than 0.2 L/(s×m<sup>2</sup>) at a pressure differential of 75 Pa and determined in accordance with Article 3.1.1.8.</p> <p data-bbox="430 906 1078 933"><b>2)</b> <i>Air barrier assemblies</i> shall conform to Sentence 3.1.1.8.(1).</p> <p data-bbox="430 947 1268 1023"><b>3)</b> Metal and glass curtain walls that act as environmental separators shall have an air leakage rate not greater than 0.2 L/(s×m<sup>2</sup>), determined in accordance with Article 3.1.1.8.(3), at a pressure differential of 75 Pa.</p> <p data-bbox="430 1037 1268 1112"><b>4)</b> Fixed windows and <i>skylights</i> that act as environmental separators shall have an air leakage rate not greater than 0.2 L/(s×m<sup>2</sup>) when tested in accordance with Sentence 3.1.1.8.(2), at a pressure differential of 75 Pa.</p> <p data-bbox="430 1127 1268 1202"><b>5)</b> Operable windows and <i>skylights</i> that act as environmental separators shall have an air leakage rate not greater than 0.5 L/(s×m<sup>2</sup>) when tested in accordance with Sentence 3.1.1.8.(2), at a pressure differential of 75 Pa.</p> <p data-bbox="430 1216 1268 1292"><b>6)</b> Except as provided in Sentences (7) to (9), doors that act as environmental separators shall have an air leakage rate not greater than 0.5 L/(s×m<sup>2</sup>) when tested in accordance with Sentence 3.1.1.8.(4), at a pressure differential of 75 Pa.</p> <p data-bbox="430 1306 1268 1435"><b>7)</b> Revolving doors and automatic commercial sliding doors, including their respective fixed sections, that act as environmental separators are permitted to have an air leakage rate not greater than 5.0 L/(s×m<sup>2</sup>) when tested as a complete assembly in accordance with Sentence 3.1.1.8.(4), at a pressure differential of 75 Pa.</p> <p data-bbox="430 1449 1268 1560"><b>8)</b> Overhead doors that act as environmental separators are permitted to have an air leakage rate not greater than 5.0 L/(s×m<sup>2</sup>) when tested as a complete assembly at a pressure differential of 75 Pa in accordance with Sentence 3.1.1.8.(4).</p> <p data-bbox="430 1575 1268 1632"><b>9)</b> Main entry exterior doors that act as environmental separators are permitted to have an air leakage rate not greater than 5.0 L/(s×m<sup>2</sup>) when tested as a complete</p>			

	assembly in accordance with Sentence 3.1.1.8.(4), at a pressure differential of 75 Pa, provided that the total area of such doors does not exceed 2% of the gross wall area calculated in accordance with Article 3.1.1.6. (See Note A-3.2.4.3.(9)).”.
<b>3.3.1.</b>	Replace the heading of the Subsection by the following: “ <b>3.3.1. General</b> ”.
<b>3.3.1.1.</b>	Replace the Article by the following: “ <b>3.3.1.1. Application</b> <b>1)</b> Subject to the limitations stated in Article 3.3.1.2., where the <i>building envelope</i> does not comply with the requirements of Section 3.2. or 3.4., it shall comply with this Section. <b>2)</b> This Section does not apply to <i>building assemblies</i> of the <i>building envelope</i> separating <i>conditioned spaces</i> intended to be conditioned to temperatures differing by more than 10°C at design conditions. <b>3)</b> For the purposes of this Section, “reference <i>building</i> ” refers to a <i>building</i> whose envelope complies with the requirements of Section 3.2.”.
<b>3.3.1.2.</b>	Replace the Article by the following: “ <b>3.3.1.2. Limitations</b> (See Note A-3.3.1.2.) <b>1)</b> The method of trade-off paths described in this Section may only take into consideration the energy performance of above-ground <i>building assemblies</i> of the <i>building envelope</i> covered in Sentences 3.2.1.2.(3), (4), (6), (7) and (10), 3.2.2.2.(1), 3.2.2.3.(2) and 3.2.2.4.(1). <b>2)</b> The <i>building envelope</i> shall comply with the requirements of Section 3.2, except the provisions listed in Sentence (1). <b>3)</b> Except as provided in Sentence 3.3.1.3.(2), performances that can be characterized in accordance with Articles 3.1.1.5. and 3.1.1.6. shall be taken into consideration in the trade-off path for a) the minimum energy performance of above-ground <i>building assembly</i> of the reference <i>building envelope</i> covered in Sentence (1), and b) the lower or higher performance of <i>building assemblies</i> of the proposed <i>building</i> covered in Sentence (1). <b>4)</b> The trade-off path shall apply individually to <i>building assemblies</i> of spaces whose heating setpoint is less than 18°C and to those whose heating setpoint is 18°C or more.”.
	Add the following Article: “ <b>3.3.1.3. Compliance</b> <b>1)</b> Except as provided in Sentence (2), compliance with this Section shall be determined using the equation that follows to demonstrate that the sum of the areas of all above-ground <i>building assemblies</i> of the proposed <i>building</i> divided

by their *effective thermal resistance* is not more than it would be if all above-ground assemblies complied with Section 3.2.:

$$\sum_{i=1}^n \frac{A_i}{RSI_{Eip}} \leq \sum_{i=1}^n \frac{A_i}{RSI_{Eir}}$$

where

$n$  = total number of above-ground assemblies,

$A_i$  = area of above-ground assembly  $i$  of the *building* calculated in accordance with the requirements of Article 3.1.1.6., in  $m^2$ ,

$RSI_{Eip}$  = *effective thermal resistance* of above-ground assembly  $i$  of the proposed *building*, in  $(m^2 \times K)/W$ , and

$RSI_{Eir}$  = *effective thermal resistance* of above-ground assembly  $i$  of the reference *building*, in  $(m^2 \times K)/W$ .

(See Note A-3.3.1.3.(1).)

**2)** Except as provided in Sentence (3), where a requirement in Sentences 3.2.1.2.(1) to (7) and (10) is not complied with, the *effective thermal resistance* of above-ground *opaque building assemblies* of the *building envelope* shall be derated using the equation that follows to take into account thermal bridging:

$$RSI_{EDi} = \frac{1}{\frac{\sum_{j=1}^m (\Psi_j \times L_j) + \sum_{k=1}^n (\chi_k \times N_k)}{A_i} + \frac{1}{RSI_{Ei}}}$$

where

$RSI_{EDi}$  = derated *effective thermal resistance* of *opaque building assembly*  $i$  of the proposed or reference *building*, in  $(m^2 \times K)/W$ ,

$\Psi_j$  = *linear thermal transmittance* of the type  $j$  intersection calculated in accordance with Sentence 3.1.1.5.(7), in  $W/(m \times K)$ ,

$L_j$  = length of the type  $j$  intersection, in  $m$ ,

$m$  = total number of types of intersections,

$\chi_k$  = *point thermal transmittance* of the type  $k$  penetration calculated in accordance with Sentence 3.1.1.5.(7), in  $W/K$ ,

$N_k$  = number of type  $k$  point penetrations,

$n$  = total number of types of penetrations,

$A_i$  = area of *opaque building assembly*  $i$ , calculated in accordance with Article 3.1.1.6., in  $m^2$ , and

$RSI_{Ei}$  = *effective thermal resistance* of the non-derated *opaque building assembly*, calculated in accordance with any of Sentences 3.1.1.5.(5) and (6), in  $(m^2 \times K)/W$ .

(See Note A-3.3.1.3.(2).)

**3)** The values in Tables 3.3.1.3.-A and 3.3.1.3.-B

a) may be used for the applicable penetrations or intersections of the proposed *building* that do not comply with Sentences 3.2.1.2.(1) to (7) and (10), and

b) shall be used for the penetrations and intersections of the reference *building* that are referred to in Clause (a).

(See Note A-3.3.1.3.(3).)

**Table 3.3.1.3.-A**  
**Default Linear Thermal Transmittance of Certain Intersections**  
 Forming Part of Sentence 3.3.1.3.(3)

Intersection	Maximum <i>Linear Thermal Transmittance</i> , $\Psi$ , in W/(m <sup>2</sup> ×K) Intersection of the reference <i>building</i>	Maximum <i>Linear Thermal Transmittance</i> <sup>(1)</sup> , $\Psi$ , in W/(m <sup>2</sup> ×K) Intersection of the proposed <i>building</i> that does not comply with the prescriptive requirements
Wall/roof	0.325	0.800
Wall/intermediate floor	0.300	0.850
Wall/projection <sup>(1)</sup>	0.500	1.000
Wall/ <i>foundation</i>	0.450	0.850
Wall/opening or wall/wall, minor <sup>(2)</sup>	0.200	0.500
Wall/wall, major <sup>(3)</sup>	0.450	0.850

**Notes to Table 3.3.1.3.-A:**

- (1) Projections include linear penetrations that fully go through or partially penetrate the building assembly, extending on the exterior side of the building assembly (e.g. a balcony).
- (2) Minor intersections are intersections that generally result in moderate thermal loss.
- (3) Major intersections are intersections that may result in more significant thermal loss.

**Table 3.3.1.3.-B**  
**Point Thermal Transmittance of Penetrations**  
 Forming Part of Sentence 3.3.1.3.(3)

	<i>Point Thermal Transmittance</i> , X, in W/K Penetration of the reference <i>building</i>	<i>Point Thermal Transmittance</i> , X, in W/K Penetration of the proposed <i>building</i> that does not comply with the prescriptive requirements
Any penetration	0.5	1.0

**4)** Where the *effective thermal resistance* of the opaque section of curtain walls has not been determined in accordance with Sentence 3.1.1.5.(6), the values that follow shall be used in the proposed *building*:

- a)  $0.35 \text{ (m}^2 \times \text{K)}/W$ , where the opaque section of curtain walls does not have an insulation material, or
- b)  $0.88 \text{ (m}^2 \times \text{K)}/W$ , where the opaque section of curtain walls has an insulation material.”.



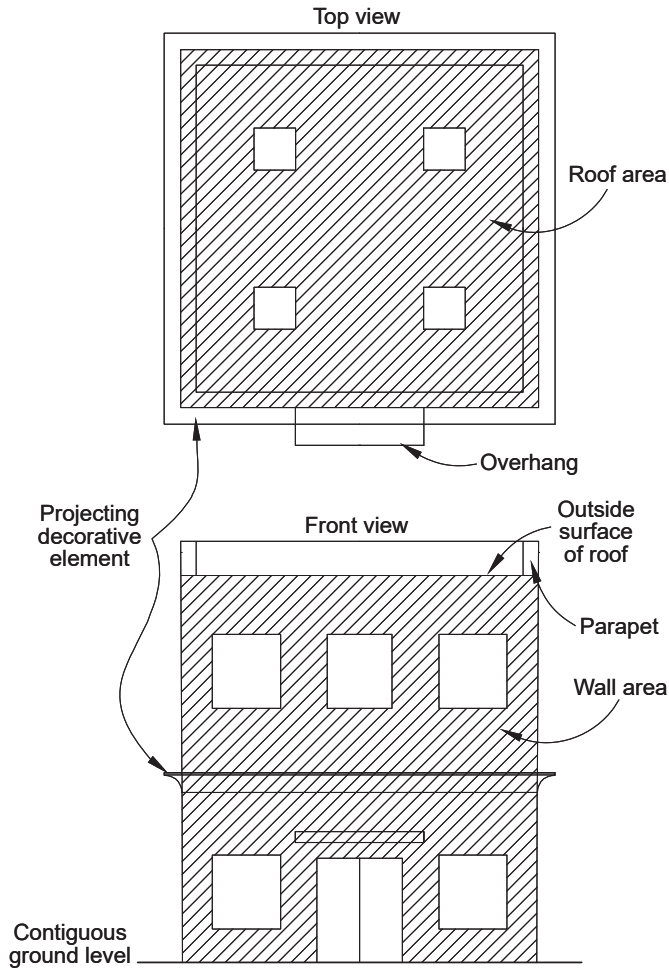
3.4.1.2.	<p>Replace the Article by the following:</p> <p><b>“3.4.1.2. Limitations</b> (See Note A-3.4.1.2.)</p> <p>1) The performance path described in this Section may only take into consideration the energy performance of the <i>building</i> assemblies of the <i>building envelope</i> covered</p> <p>a) in Articles 3.2.1.2. to 3.2.1.4. and 3.2.2.2 to 3.2.2.4., and</p> <p>b) except as provided in Sentence 8.4.3.3.(7), in Subsection 3.2.3.</p> <p>2) The <i>building</i> assemblies of the <i>building envelope</i> that are not covered in Sentence (1) shall comply with the requirements of Section 3.2.”.</p>
3.5.1.1.	<p>Replace the heading of the appropriate Article in Table 3.5.1.1. by the following:</p> <p><b>“3.3.1.2. Limitations”;</b></p> <hr/> <p>Replace respectively, in numerical order, the headings, objectives and functional statements in Table 3.5.1.1. by the following:</p> <p><b>“3.1.1.7. Calculation of Effective Thermal Resistance</b></p> <p>(1) [F92-OE1.1]</p> <p>(7) [F92-OE1.1]</p> <p>(8) [F92-OE1.1]</p> <p>(9) [F92-OE1.1]”;</p> <p><b>“3.2.1.2. Continuity of Insulation</b></p> <p>(1) [F92-OE1.1]</p> <p>(3) [F92-OE1.1]</p> <p>(4) [F92-OE1.1]</p> <p>(5) [F92-OE1.1]</p> <p>(6) [F92-OE1.1]</p> <p>(7) [F92-OE1.1]</p> <p>(8) [F92-OE1.1]</p> <p>(10) [F92-OE1.1]”;</p> <p><b>“3.2.1.3. Spaces Conditioned to Different Temperatures</b></p> <p>(1) [F92-OE1.1]</p> <p>(2) [F92-OE1.1]”;</p> <p><b>“3.2.2.2. Thermal Characteristics of Above-ground Opaque Building Assemblies</b></p> <p>(1) [F92-OE1.1]</p> <p>(2) [F92-OE1.1]</p> <p>(4) [F92,F95-OE1.1]”;</p>

<p><b>“3.2.3.1. Thermal Characteristics of Walls in Contact with the Ground</b></p> <p>(1) [F92-OE1.1]</p> <p>(3) [F92-OE1.1]</p> <p>(4) [F92,F95-OE1.1]</p> <p>(5) [F92-OE1.1]”;</p> <p><b>“3.2.3.2. Thermal Characteristics of Roofs in Contact with the Ground</b></p> <p>(1) [F92-OE1.1]”;</p> <p><b>“3.2.3.3. Thermal Characteristics of Floors in Contact with the Ground</b></p> <p>(2) [F92-OE1.1]</p> <p>(3) [F92-OE1.1]”;</p> <p><b>“3.3.1.1. Application</b></p> <p>(2) [F92-OE1.1]”;</p> <p><b>“3.4.1.2. Limitations</b></p> <p>(1) [F90,F92-OE1.1]</p> <p>(2) [F92-OE1.1]”;</p> <hr/> <p>Insert respectively in Table 3.5.1.1, in numerical order, the following objectives and functional statements:</p> <p><b>“3.1.1.5. Thermal Characteristics of Building Assemblies</b></p> <p>(6) [F92-OE1.1]</p> <p>(7) [F92-OE1.1]”;</p> <hr/> <p>Insert in Table 3.5.1.1., in numerical order, the following Articles, objectives and functional statements:</p> <p><b>“3.1.1.8. Air Leakage in Building Assemblies</b></p> <p>(1) [F90-OE1.1]</p> <p>(2) [F90-OE1.1]</p> <p>(3) [F90-OE1.1]</p> <p>(4) [F90-OE1.1]”;</p> <p><b>“3.3.1.3. Compliance</b></p> <p>(1) [F92-OE1.1]</p> <p>(2) [F92-OE1.1]</p> <p>(4) [F92-OE1.1]”;</p> <hr/> <p>Strike out the following objectives and functional statements in Table 3.5.1.1.:</p> <p><b>“3.2.4.2. Opaque Building Assemblies</b></p> <p>(1) [F90-OE1.1]</p>
--

	(2) [F90-OE1.1]”.
<b>Division B Part 3 Schedule A</b>	
	<p>Add the following Note:</p> <p><b>“A-3.1.1.2.(1)(b) Building with Low Heat Requirement.</b> The exemption provided for in Clause 3.1.1.2.(1)(b) could apply, for example, to buildings in which permanent processes produce at all times sufficient heat so that no other heating source of a capacity of more than 10 W/m<sup>2</sup> is necessary to ensure comfort for the occupants during the whole year.”.</p>
<b>A-3.1.1.5.(5)(a)</b>	<p>Replace the Note by the following:</p> <p><b>“A-3.1.1.5.(5)(a) Calculation of the Effective Thermal Resistance of Opaque Building Assemblies using Simplified Calculation Methods.</b> The recognized simplified calculation methods are those from standard organizations such as ASHRAE, ISO et Codes Canada. The method for calculating isothermal planes described in the “ASHRAE Handbook – Fundamentals” may in particular be used for calculating the effective thermal resistance of assemblies that have a discontinuity in insulation layers. To implement that simplified calculation method, the material creating the discontinuity in the insulating layer must have a thermal conductivity slightly different from that of the insulating layer, as is the case for assemblies with wood frames. That method could not apply to a metal frame assembly because the difference in thermal conductivity between the frame and the insulation is too high.</p> <p>The simplified calculation method described in ISO 6946, “Building components and building elements -- Thermal resistance and thermal transmittance -- Calculation methods” for an assembly composed of homogeneous and heterogeneous layers may also be used for calculating the effective thermal resistance of assemblies that have a discontinuity in insulation layers. To implement that simplified calculation method, the material creating the discontinuity in the insulating layer must have a thermal conductivity slightly different from that of the insulating layer. Where the main frame of the assembly is composed of metal posts, the calculation method must be adapted. Weighing coefficients must be applied based on the configuration of the main frame. The adapted methods described in Note A-9.36.2.4.(1) of the NBC or in “BRE Digest 465” are examples of calculation rules using weighing coefficients that may be applied to that type of assembly. That adapted solution for calculating the effective thermal resistance applies only for simple metal frames, that is, where there is absence of double frame and horizontal, vertical or point resilient bars, or where there is absence of any other complex assembly of a similar nature that may affect heat flow, in which case the digital simulation of the heat transfer or a laboratory test is used to determine the effective thermal resistance of those assemblies.”.</p>
	<p>Add the following Note:</p>

	<p><b>“A-3.1.1.5.(5)(b), (6)(c) and (7)(a) Digital Simulation of Heat Transfer.</b> The “ASHRAE Handbook – Fundamentals” refers to the approach developed as part of research project ASHRAE RP-1365, “Thermal Performance of Building Envelope Details for Mid- and High-Rise Buildings” (Morrison Hershfield), for calculating thermal characteristics of building assemblies.</p> <p>The thermal characteristics of building assemblies determined according to such an approach involve the implementation of digital simulation tools that allow to obtain, using a finite element analysis, the distribution of heat under steady state in a building assembly. The thermal characteristics such as linear and point thermal transmittance or the effective thermal resistance of a building assembly may be determined with that type of simulation.”.</p> <p>ISO 14683 “Thermal bridges in building construction – Linear thermal transmittance – Simplified methods and default values”, ISO 10211 “Thermal bridges in building construction – Heat flows and surface temperatures – Detailed calculations”, the “Building Envelope Thermal Bridging Guide” by Morrison Hershfield, and research project report ASHRAE RP-1365, “Thermal Performance of Building Envelope Details for Mid- and High-Rise Buildings”, are also acceptable sources of information for calculating the effective thermal resistance of certain specific building assemblies and the incidence of thermal bridges.”.</p>
<b>A-3.1.1.6.(1)</b>	<p>Insert the following Sentences after the first Sentence of the Note:</p> <p>“Garage doors are included in the calculation of the door and fenestration area of a building.</p> <p>The opaque sections (spandrel panels) of curtain walls are part of the opaque building assembly. That component of curtain walls shall be taken into account in the calculation of the area of opaque building assemblies and not in the calculation of the fenestration and door area.”.</p>
	<p>Add the following Note:</p> <p><b>“A-3.1.1.6.(6) Calculation of the Area of Opaque Building Assemblies.</b> Parapets, projected fins, ornamentation, appendages, and fenestration and doors, are excluded from the area of opaque building assemblies. The area of an opaque building assembly in contact with the ground shall be calculated from the exterior ground level to the bottom surface of the slab-on-ground.</p>

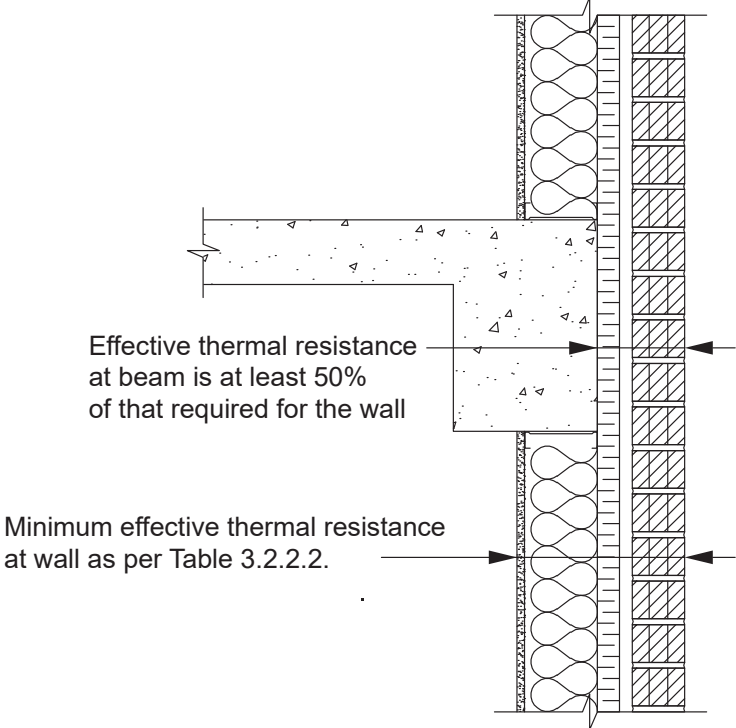
Figure A-3.1.1.6.(6) illustrates the calculation of the area of opaque building assemblies according to the requirements of Sentence 3.1.1.6.(6).



**Figure A-3.1.1.6.(6)**  
**Calculation of the Area of Opaque Building Assemblies”.**

<p><b>A-3.1.1.7.(1)(b)</b></p>	<p>Strike out the Note.</p>
<p><b>A-3.1.1.7.(1)(d)</b></p>	<p>Strike out the Note.</p>

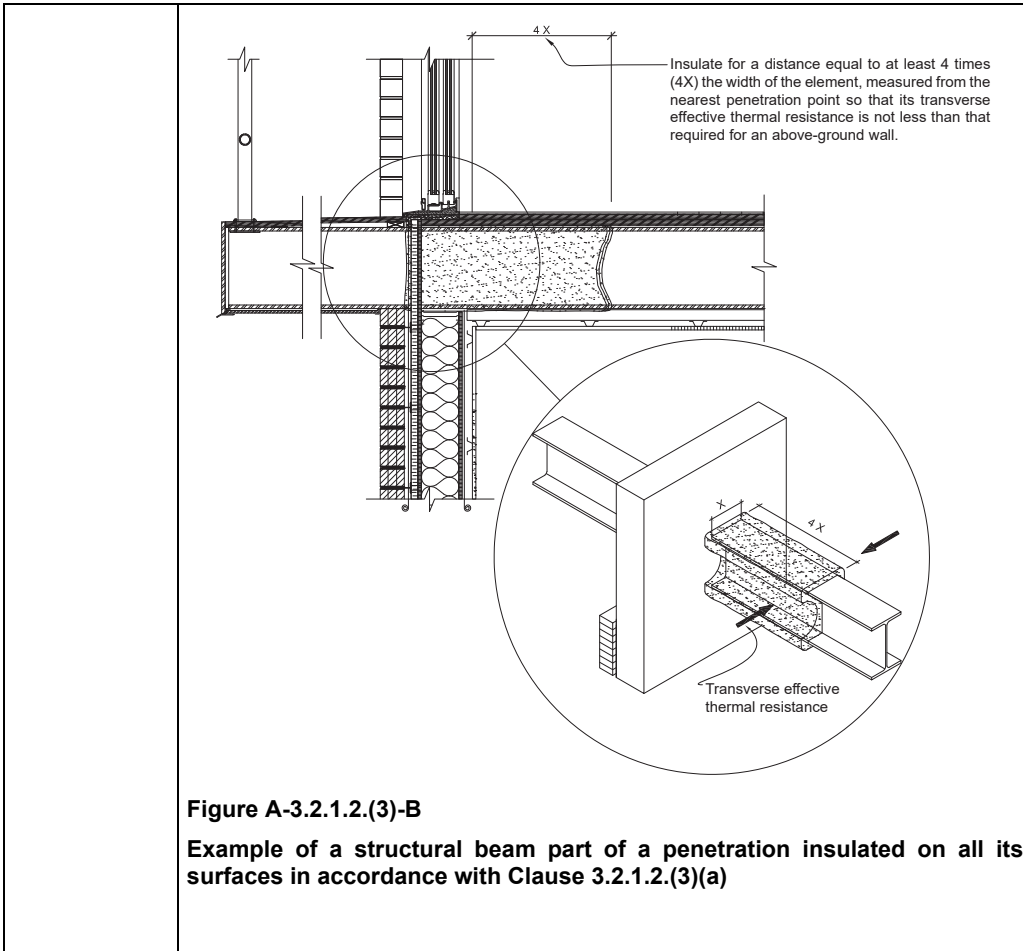
	<p>Add the following Note:</p> <p><b>“A-3.1.1.7.(1) Calculation of the Effective Thermal Resistance of Opaque Building Assemblies of the Building Envelope.</b> For calculating the effective thermal resistance, Part 3 requires that the contribution of all continuous components of the envelope such as the insulation, siding and sheathing, of all repetitive structural members, such as columns, studs and resilient bars, and all secondary structural members such as lintels, sills and plates, be taken into account. Members that break the building envelope, such as beams, studs, joists and balconies, also have an effect on overall effective thermal resistance, but are excluded from the calculations of the effective thermal resistance, except as provided in Article 3.1.1.7. and Section 3.3. Those elements are the subject of prescriptive requirements detailed in Article 3.2.1.2.”.</p>
--	--

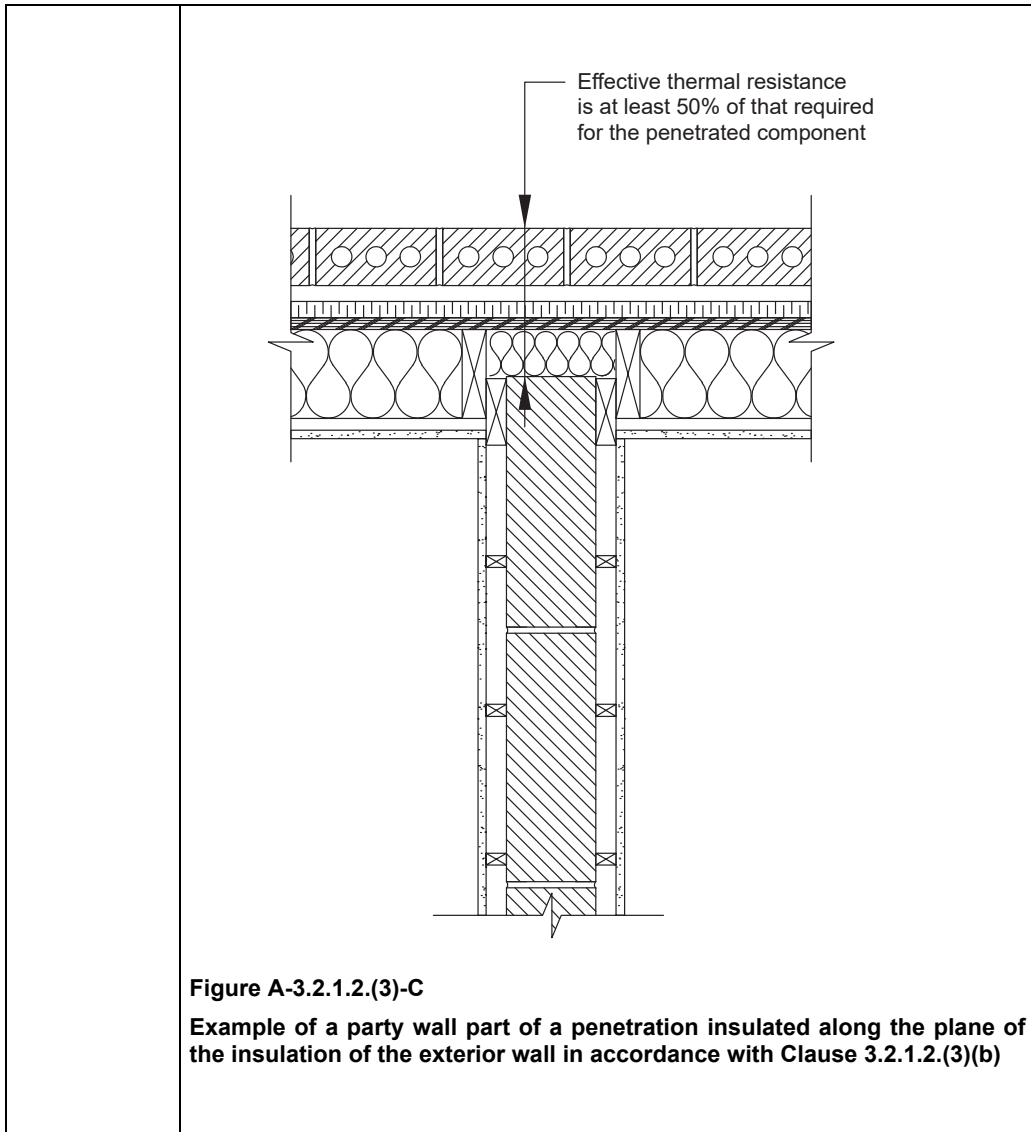
<p><b>A-3.1.1.7.(2)</b></p>	<p>Replace the Note by the following:</p> <p><b>“A-3.1.1.7.(2) Continuity of Insulation at Beams and Columns.</b> The effective thermal resistance at spandrel beams may be reduced compared to what is required for walls penetrated by beams without any penalty, provided that the resulting effective thermal resistance across the building envelope at the spandrel beam is not less than half the required effective thermal resistance for the wall (see Figure A-3.1.1.7.(2)). A similar approach may be used for columns in exterior walls.</p>  <p>Effective thermal resistance at beam is at least 50% of that required for the wall</p> <p>Minimum effective thermal resistance at wall as per Table 3.2.2.2.</p> <p><b>Figure A-3.1.1.7.(2)</b> <b>Continuity of insulation at beams.”</b></p>
	<p>Add the following Note:</p> <p><b>“A-3.1.1.7.(3) Penetrations of the Building Envelope.</b> The minor ties and anchors necessary for the assembly of the envelope, such as screws, bolts and masonry anchors, may be excluded from the calculation of the effective thermal resistance for demonstrating compliance. Other partial or complete discontinuities of insulation listed in Sentence 3.1.1.7.(3) need not be part of the calculation of the effective thermal resistance of the opaque building assembly affected where the penetrations comply with the requirements of Article 3.2.1.2.</p>

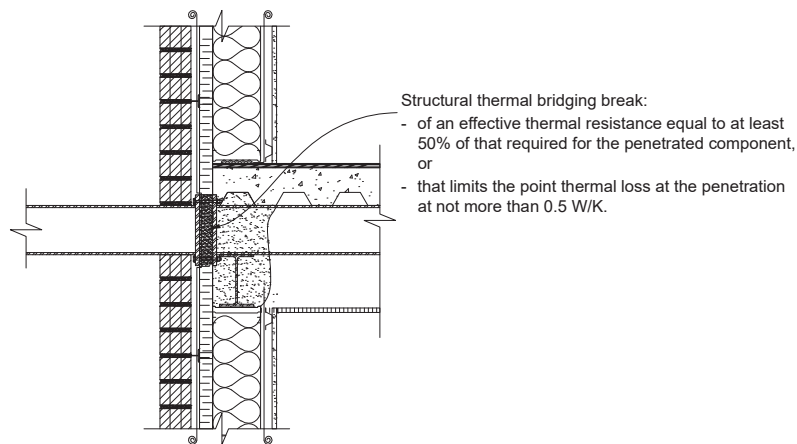
	<p><b>Permafrost</b></p> <p>Penetrations caused by metal pilings supporting the buildings constructed in permafrost regions need not be part of the calculation of the effective thermal resistance of the opaque building assembly where the penetrations comply with the requirements of Article 3.2.1.2.”.</p>
<b>A-3.1.1.7.(4)</b>	<p>Replace the Note by the following:</p> <p><b>“A-3.1.1.7.(4) Effect of an Unconditioned Space.</b> The effective thermal resistance required in Sentence 3.1.1.7.(4), which is equivalent to that of a layer of glass, is intended to provide an easy credit under the prescriptive path for any unconditioned space that may be protecting a component of the building envelope.</p> <p>The value given does not take into account the construction of the enclosure surrounding the unconditioned space; the construction of this enclosure being uncontrolled by this Code, too many variables, such as its size or airtightness, may negate any higher credit that could be allowed. There may be simulation tools under the performance path that can provide a better assessment of the effect of an unheated space, which may be used to advantage when an unheated space is designed to provide significantly better protection than the assumed worst-case scenario. Vented spaces, such as attic and roof spaces or crawl spaces, are considered to be part of the exterior space; therefore, Sentence 3.1.1.7.(4) does not apply when calculating the effective thermal resistance of building envelope components.”.</p>
	<p>Add the following Note:</p> <p><b>“A-3.1.1.8.(1) Air Barrier Assembly Testing.</b> Air barrier assemblies of the envelope of a building are subject to structural loading induced by mechanical systems, wind pressure and stack effect. Those assemblies may also be affected by physical degradation resulting from thermal or structural movement throughout time.</p> <p>The limits of the tests to be conducted in accordance with CAN/ULC-S742, “Air Barrier Assemblies – Specification,” and ASTM E 2357, “Standard Test Method for Determining Air Leakage of Air Barrier Assemblies,” are indicated in the test procedures to which they refer.”.</p>
<b>A-3.2.1.1.(1)</b>	<p>Strike out “vegetative roofing systems,” in the Note.</p>
	<p>Add the following Note:</p> <p><b>“A-3.2.1.2.(1) Continuity of Insulation.</b> Sentence 3.2.1.2.(1) applies to building components such as wall assemblies, chimneys, fireplaces, and columns and beams that are embedded along exterior walls, but not to stud framing and ends of joists. Studs and joists in frame construction are not considered to break the continuity of the insulation. The Sentence also applies to components of mechanical and electrical systems in walls, roofs or floors.”.</p>



<p><b>A-3.2.1.2.(2)</b></p>	<p>Replace the Note by the following:</p> <p><b>“A-3.2.1.2.(2) Structural Members and Minor Penetrations.</b> Sentence 3.2.1.2.(2) takes into account the fact that repetitive structural members are already included in the method for calculating effective thermal resistance of building assemblies as described in Article 3.1.1.7.</p>
	<p>Add the following Notes:</p> <p><b>“A-3.2.1.2.(3) Break in the Continuity of Insulation.</b> Where they penetrate the envelope, interior walls, foundation walls, firewalls, party walls, structural members such as slabs, ornamentations and other appendages are an important source of heat losses and have a significant impact on the overall thermal performance of the building envelope.</p> <p>Figures A-3.2.1.2.(3)-A, A-3.2.1.2.(3)-B, A-3.2.1.2.(3)-C and A-3.2.1.2.(3)-D illustrate ways to comply with the requirements of Sentence 3.2.1.2.(3).</p> <p>The effective thermal resistance of the assembly is at least that required for an above-ground wall.</p> <p><b>Figure A-3.2.1.2.(3)-A</b></p> <p><b>Example of a firewall part of a penetration insulated on both of its sides in accordance with 3.2.1.2.(3)(a)</b></p>







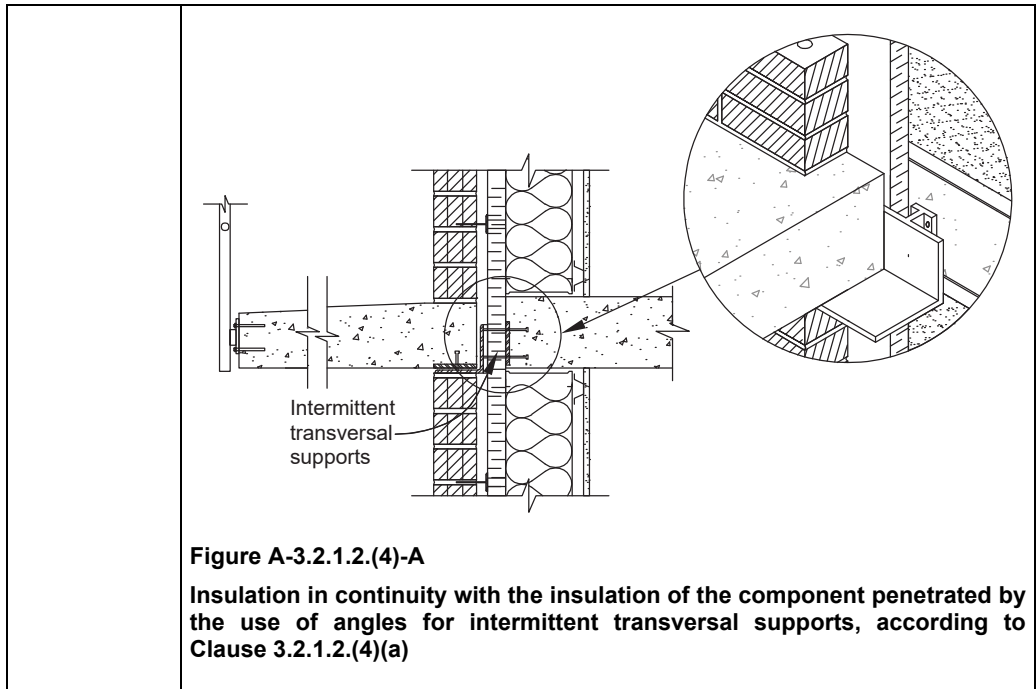
**Figure A-3.2.1.2.(3)-D**

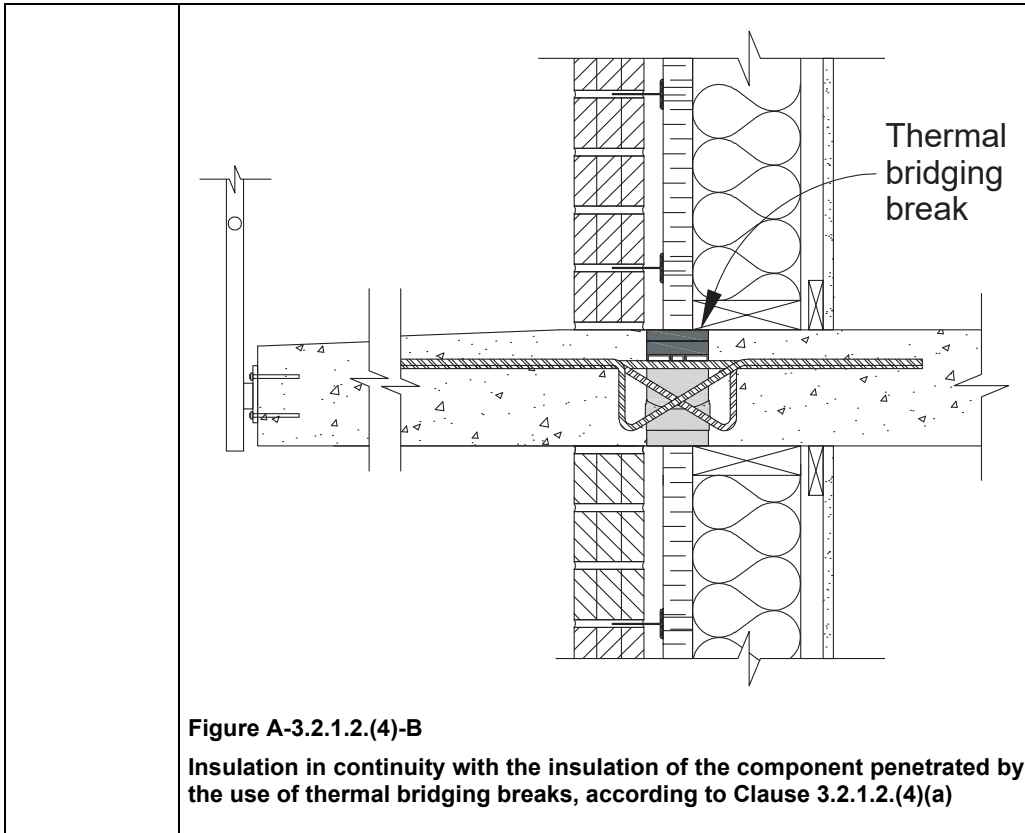
**Example of a structural beam part of a penetration insulated along the plane of the insulation of the exterior wall in accordance with Clauses 3.2.1.2.(3)(b) and 3.2.1.2.(10)**

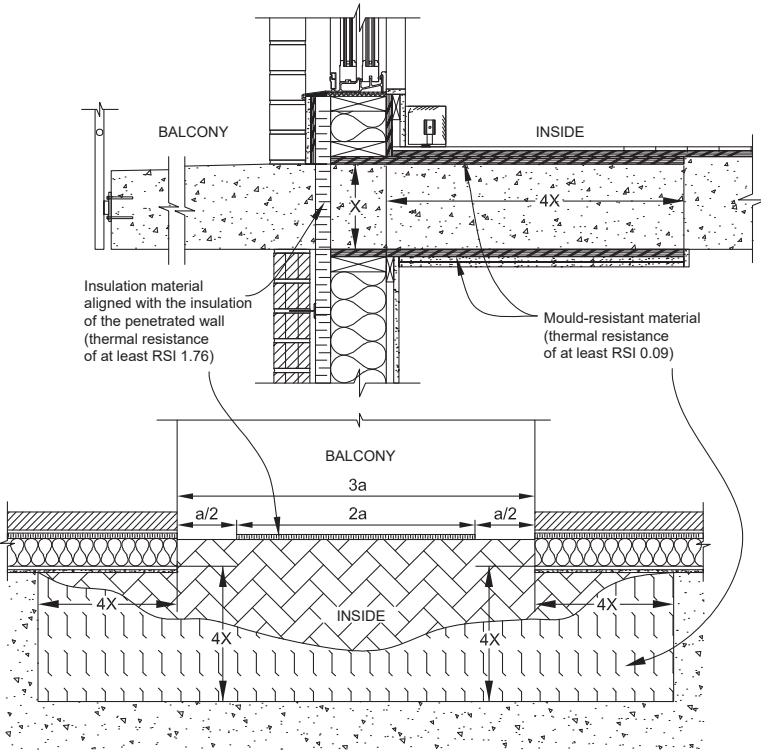
**A-3.2.1.2.(4) Insulation of a Concrete Slab.** Sentence 3.2.1.2.(4) is intended to limit heat loss at the level of concrete structural slabs that are often extended outward to become balconies. That heat loss results in an excessive energy consumption and may also be the source of discomfort for occupants. Figures A-3.2.1.2.(4)-A, A-3.2.1.2.(4)-B and A-3.2.1.2.(4)-C show ways to comply with the requirements of Sentence 3.2.1.2.(4).

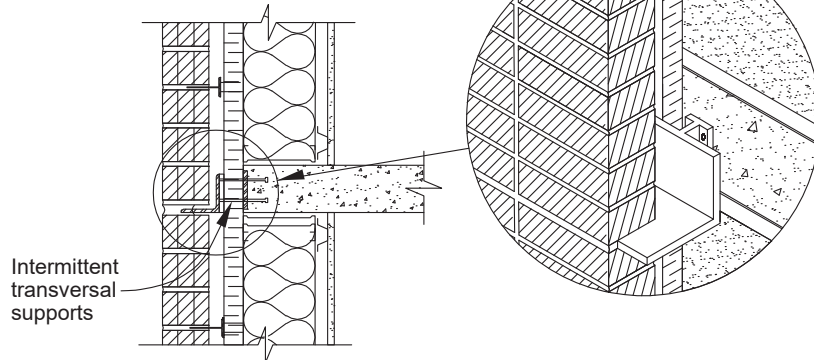
The effective thermal resistance of the structural thermal bridging breaker excludes metal reinforcing members.

Where the assembly complies with the requirements of Clause 3.2.1.2.(4)(b), the insulation material under and above the slab should be mould resistant.





	 <p><b>Figure A-3.2.1.2.(4)-C</b>  <b>Insulation of a balcony slab over two thirds of its surface, according to Clause 3.2.1.2.(4)(b)</b></p>
	<p><b>A-3.2.1.2.(5) Intermittent Transversal Supports.</b> Sentence 3.2.1.2.(5) is intended to reduce the contact surface between anchoring devices and structural members to limit heat loss at the level of those elements. Figure A-3.2.1.2.(5) shows how to comply with the requirements of Sentence 3.2.1.2.(5). It should be noted that Sentence 3.2.1.2.(3) provides for requirements concerning the insulation of the slab.</p>



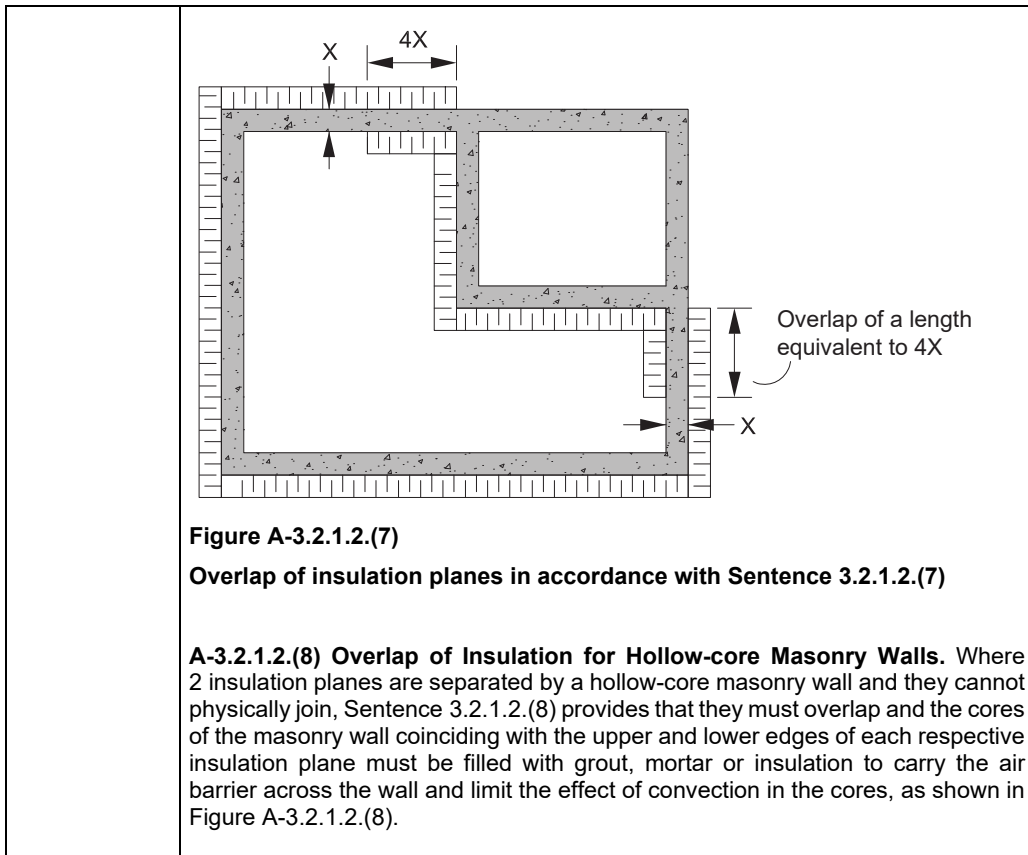
**Figure A-3.2.1.2.(5)**

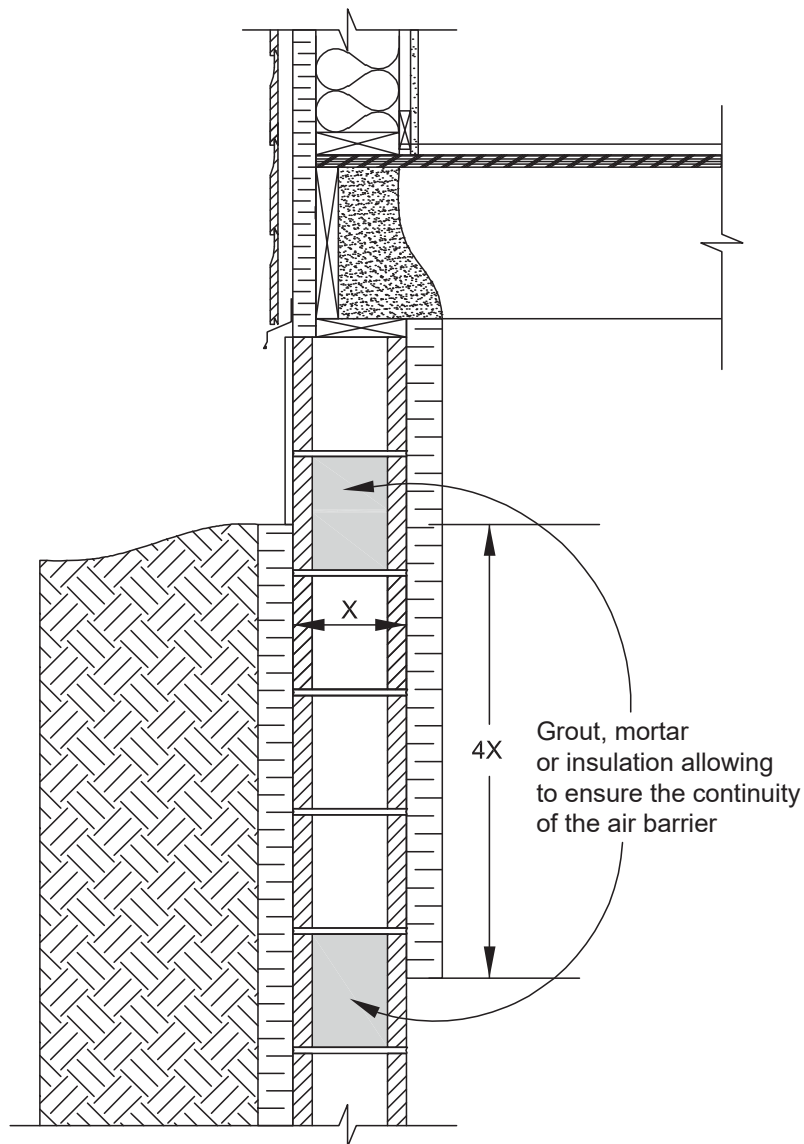
**Shelf angle attached to intermittent transversal supports**

**A-3.2.1.2.(6) Continuity of Insulation Where Components Meet.** Sentence 3.2.1.2.(6) calls for continuity of the insulation at the intersection of two components of the building envelope, such as a wall with another wall or a roof, or a wall with a window. This means that there should be no gap in the insulation between the two components. An obvious application is insulating the space between a window or door frame and the rough framing members. However, structural members, such as studs and top plates, do not have to be taken into account, as provided in Sentences 3.1.1.7.(1) and 3.2.1.2.(2).”

**A-3.2.1.2.(7) Insulation Overlap.** Where the break in insulation is due to the perpendicular interposition of a member of the envelope relative to another, Sentence 3.2.1.2.(7) requires that the overlap be carried out to extend the path of least thermal resistance from the inside out or toward an unconditioned adjacent space, as illustrated in Figure A-3.2.1.2.(7).



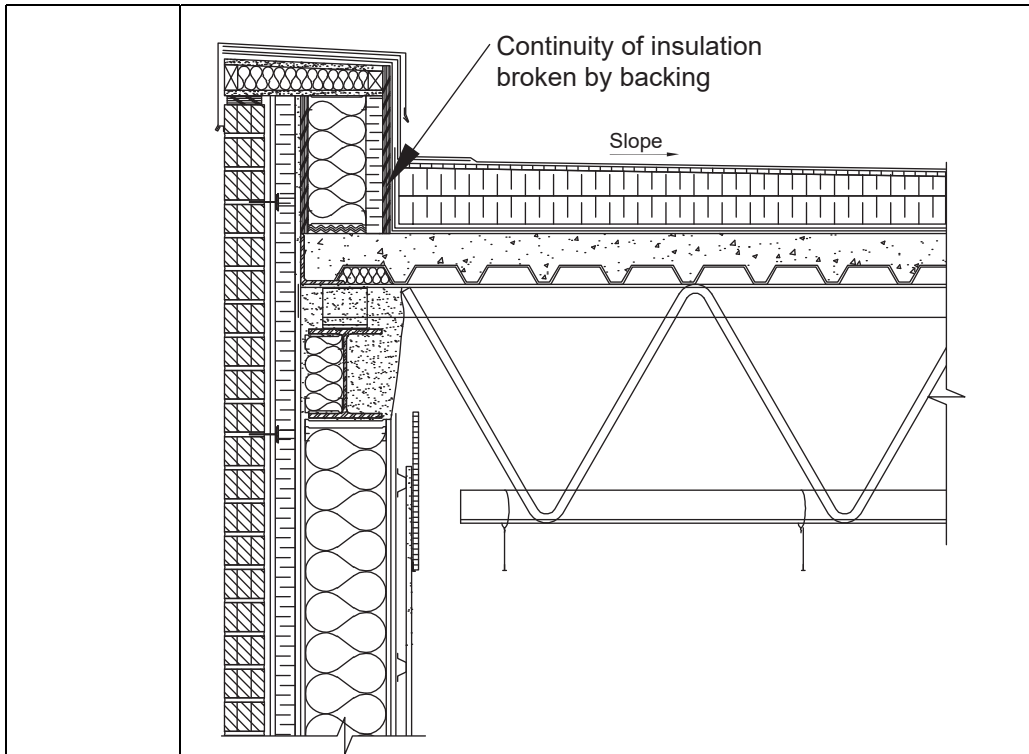




**Figure A-3.2.1.2.(8)**

**Overlap of insulation planes for hollow-core masonry walls**

**A-3.2.1.2.(9)(c) Continuity of Insulation at the Level of Parapets.** The continuity of insulation may be broken at minor transitions between constructive systems, such as backing necessary to attach the membrane, tie rods and flashings. Figure A-3.2.1.2.(9)(c) shows an example where insulation is broken by backing.



**Figure A-3.2.1.2.(9)(c)**

**Example of continuity of insulation at the level of the parapet broken by backing”.**

**A-3.2.1.3.(1)**

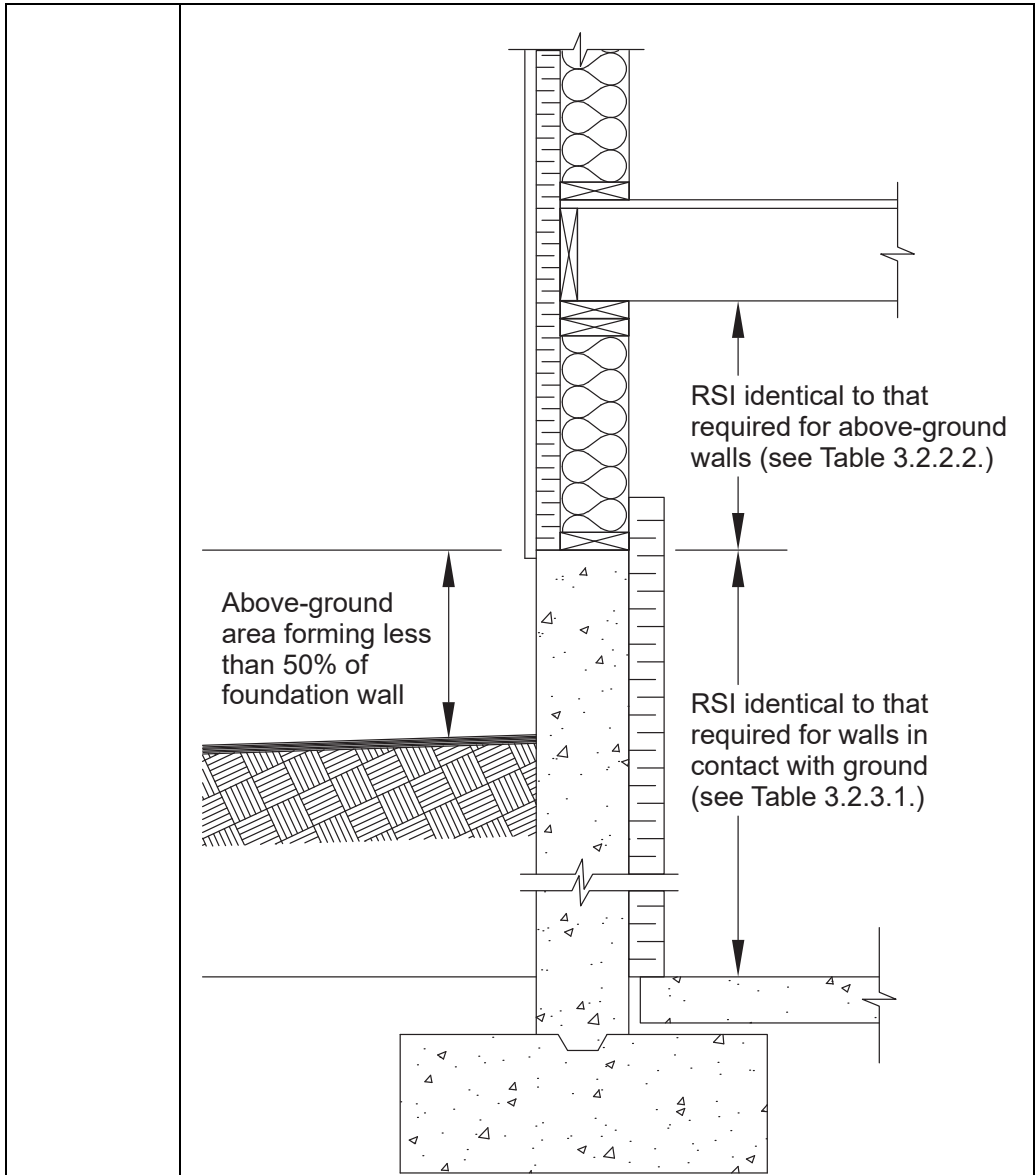
Replace the Note by the following:

**“A-3.2.1.3.(1) Spaces Heated or Cooled to Different Temperatures.** This requirement applies, for example, to walls or floors that separate a space heated to a normal comfort temperature from another space maintained at a significantly lower temperature. This would be the case, for example, of a wall between an office block and an attached warehouse that is heated just to keep it above freezing.

The value of the effective thermal resistance of building assemblies separating 2 spaces at different temperatures varies on the basis of the temperature difference between the spaces and does not depend on the location of the building. That effective thermal resistance is calculated from a reference value corresponding to the effective thermal resistance of building assemblies for less than 6000 degree-days of heating at 18°C.

This requirement also applies to doors, windows and *skylights*.”.

	<p>Add the following Note:</p> <p><b>“A-3.2.1.3.(2) Semi-Heated Spaces.</b> The Sentence applies to building assemblies of the envelope separating spaces heated to keep them above freezing. Given that setpoint, heat losses are reduced in winter. The heating setpoint is the temperature determined for the design of the heating system, and the outdoor heating design temperature is the 2.5% January design temperature according to the location of the building. The Sentence does not apply to spaces that must be conditioned to an indoor temperature of less than 18°C, such as a refrigerated warehouse.</p> <p>This requirement also applies to doors, windows and <i>skylights</i>.”</p>
<b>A-3.2.1.4.(1)</b>	Strike out the Note.
<b>A-3.2.2.2.(1)</b>	<p>Replace the Note by the following:</p> <p><b>“A-3.2.2.2.(1) Thermal Characteristics of Opaque Above-ground Building Assemblies.</b> The effective thermal resistance required for above-ground walls also applies to opaque sections of curtain walls and to the above-ground portion of foundation walls, except as provided in Sentence 3.2.2.2.(2).</p> <p>If no RSI value may be obtained for a material or assembly according to the requirements of Article 3.1.1.5., then no RSI value may be allocated to the material or assembly concerned. A high sun reflectance index of a roof covering does not allow the reduction of the effective thermal resistance required for the roof.”</p>
<b>A-Table 3.2.2.2.</b>	Strike out the Note.
	<p>Add the following Note:</p> <p><b>“A-3.2.2.2.(2) and (3) Insulation of an Exterior Wall.</b> The percentage of the exposed surface of the foundation walls must be established by considering each wall located in a same plane and for each storey. Where the foundation walls comprise various constructive systems, the percentage of the exposed surface is considered separately for each system. The entire above-ground surface of a foundation wall exposed to air over more than 50% of its surface will be insulated as an above-ground wall and the portion below ground level will be insulated as a wall in contact with the ground. Figure A-3.2.2.2.(2) and (3) shows an example of the application of Sentence (2).</p>



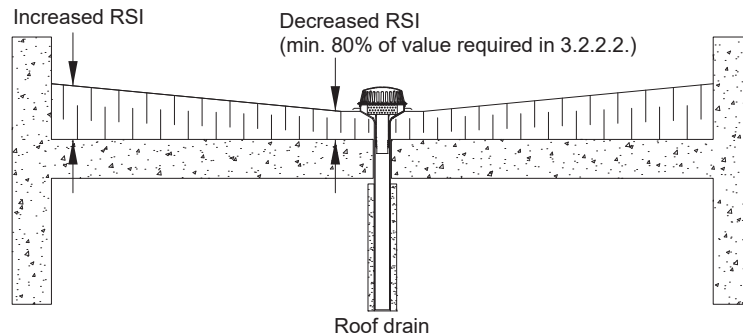
**Figure A-3.2.2.2.(2) and (3)**  
**Insulation of a foundation wall having less than 50% of the surface exposed to outdoor air".**

**A-3.2.2.2.(4)** Replace the Note by the following:  
**"A-3.2.2.2.(4) Thermal Characteristics of Above-ground Opaque Building Assemblies with Embedded Radiant Heating or Cooling.** Sentence 3.2.2.2.(4) applies in particular to overhanging floors and to insulated walls and top-storey

ceilings under a roof or unheated attic space. The requirement also applies to floors above a crawl space, where it is kept at a temperature that differs by more than 10°C. The minimum thermal resistance of a floor, wall or ceiling containing radiant heating cables or heating or cooling pipes or membranes is increased to minimize heat losses due to the increased temperature difference between the interior and exterior surfaces.”.

Add the following Notes:

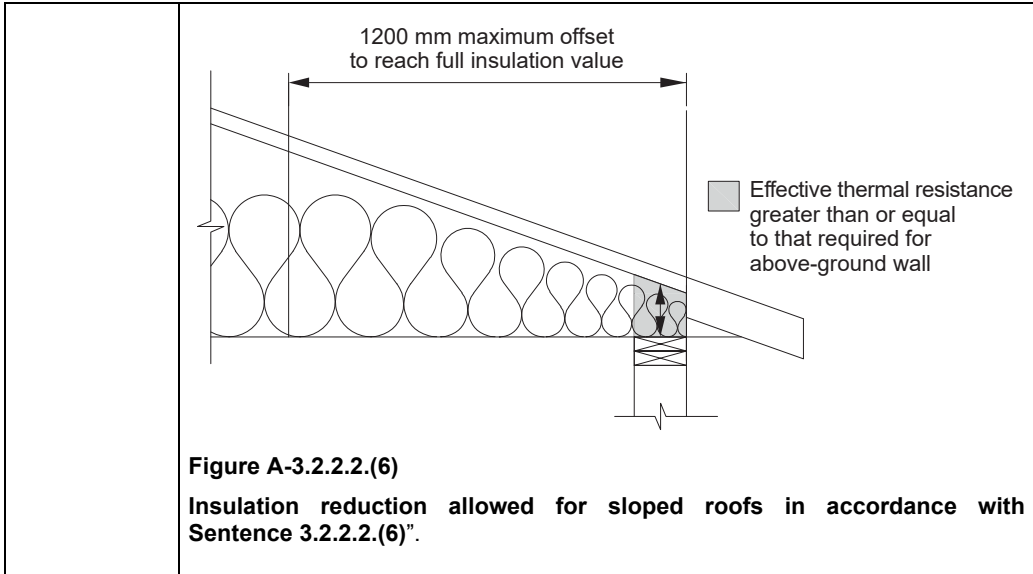
**“A-3.2.2.2.(5) Effective Thermal Resistance of a Flat Roof.** Sentence 3.2.2.2.(5) allows the reduction of the effective thermal resistance around the drain of a roof provided that the dimension of the roof and the slope are sufficient to offset heat losses incurred in the portion that does not comply with the requirements of Article 3.2.2.2. Figure A-3.2.2.2.(5) illustrates the application.



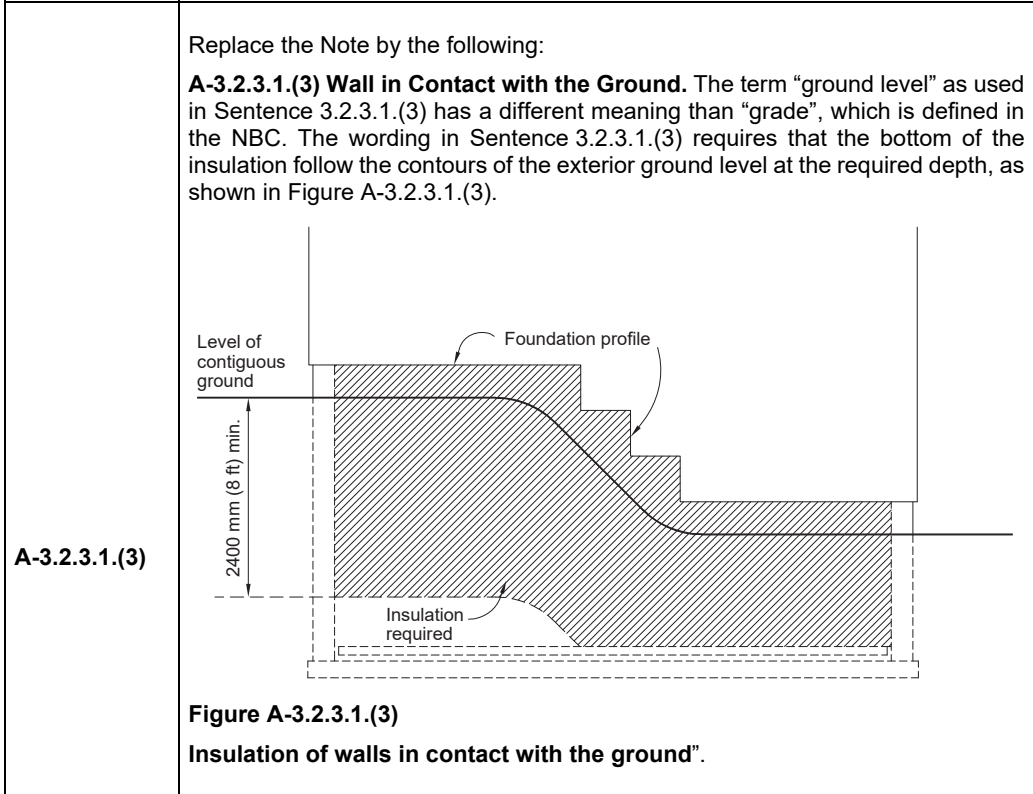
**Figure A-3.2.2.2.(5)**

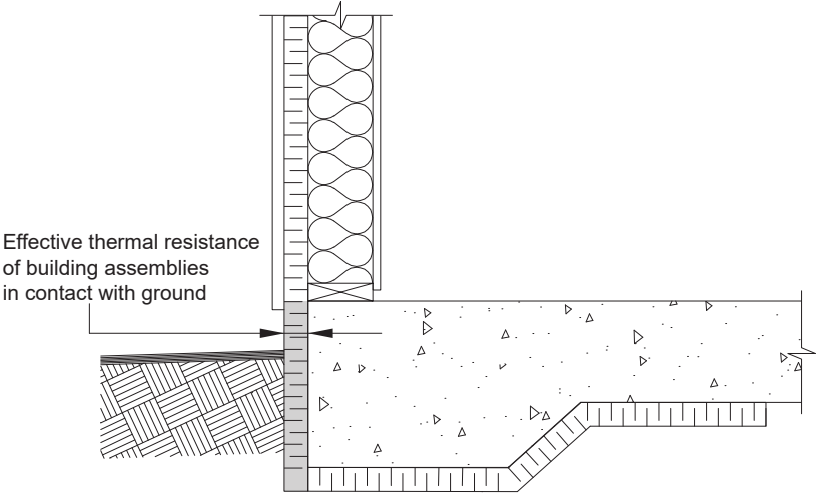
**Reduction of the sloped insulation on a flat roof in accordance with Sentence 3.2.2.2.(5)**

**A-3.2.2.2.(6) Effective Thermal Resistance Near the Eaves.** The values of the effective thermal resistance required for roofs with attic spaces are greater than those required for walls. The reduction allowed in Sentence 3.2.2.2.(6) assumes that the thickness of the insulation will be increased on the basis of the increase of the slope of the roof with an attic space until the space is sufficient to contain the full thickness of the insulation. Figure A-3.2.2.2.(6) illustrates the reduction allowed in that Article.

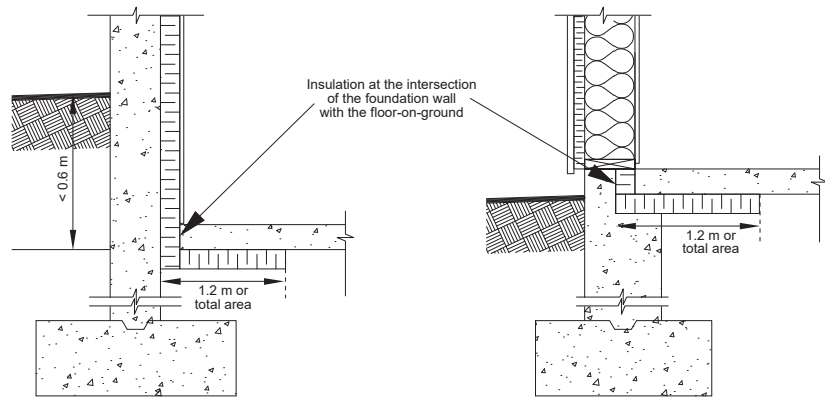


**A-3.2.2.4.(5)** Strike out the Note.



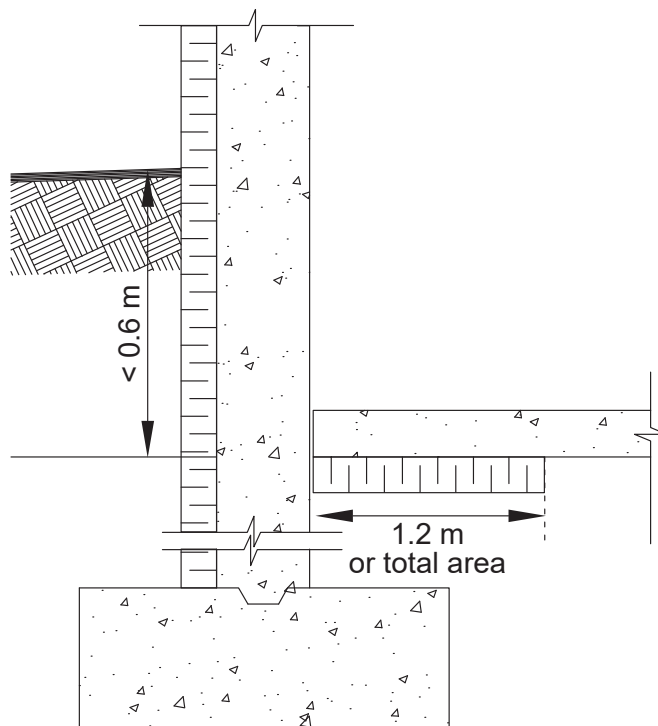
	<p>Add the following Note:</p> <p><b>“A-3.2.3.1.(5) Slab-on-Ground.</b> Sentence 3.2.3.1.(5) requires that the vertical section of a slab-on-ground be insulated over its entire height just like a wall in contact with the ground in accordance with the requirements of Sentence 3.2.3.1.(1), as shown in Figure A-3.2.3.1.(5).</p>  <p><b>Figure A-3.2.3.1.(5)</b> <b>Vertical insulation of a slab-on-ground according to Sentence 3.2.3.1.(5)”. </b></p>
<p><b>A-3.2.3.2.(1)</b></p>	<p>Replace the word “grade” wherever it appears by “ground level”;</p> <hr/> <p>Strike out the last sentence of the Note.</p>
<p><b>A-3.2.3.3.</b></p>	<p>Replace the Note by the following:</p> <p><b>“A-3.2.3.3. Floors in Contact with the Ground.</b> Article 3.2.3.3. is also intended to include “floors” of heated or cooled crawl spaces even when there is no actual constructed “floor”.</p> <p>The value of the most astringent thermal resistance determines that of the insulation material to be installed over the entire floor surface where the ground level adjacent to a floor-on-ground is variable according to the faces of an immovable. In the case of a building whose floor-on-ground is constructed in tiers, it is possible to apply the requirements of Article 3.2.3.3. to each tier. Consideration should be given to insulating the entire floor at sites where the soil is highly conductive or where there is a permanently high water table. Figures A-3.2.3.3.-A, A-3.2.3.3.-B, A-3.2.3.3.-C and A-3.2.3.3.-D illustrate the requirements in insulation for various types of floors-on-ground where these are less than 0.6 m below grade.</p>





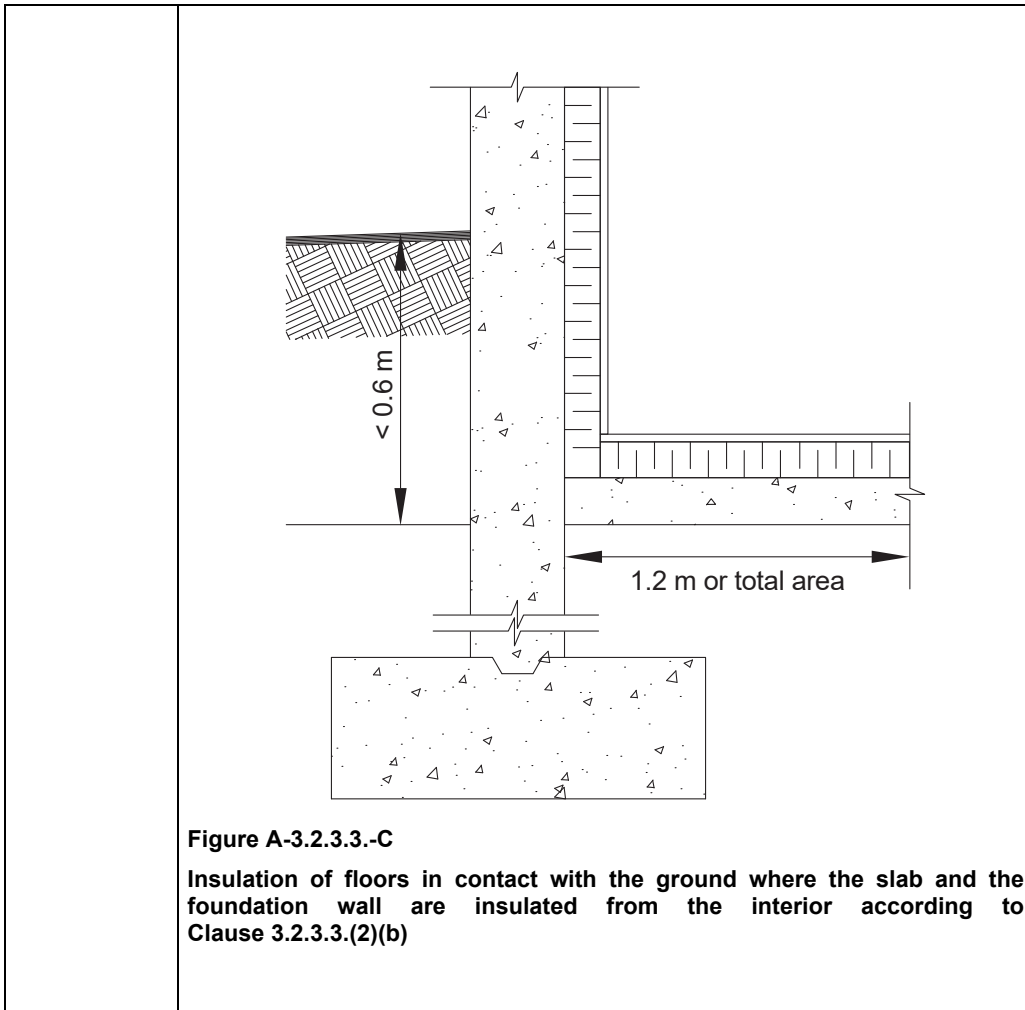
**Figure A-3.2.3.3.-A**

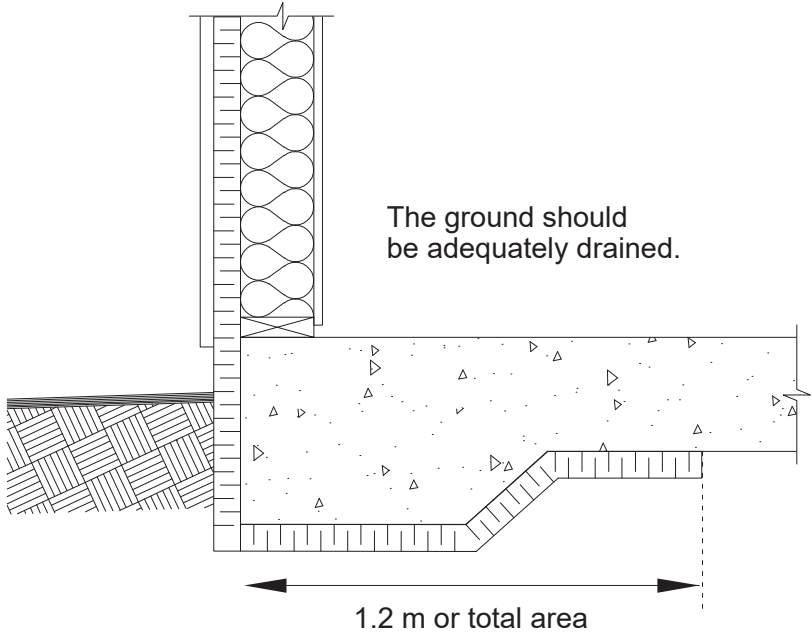
**Insulation of floors in contact with the ground – example of insulation under the slab and at the intersection of the foundation wall with the floor-on-ground according to Sentence 3.2.3.3.(1)**



**Figure A-3.2.3.3.-B**

**Insulation of floors in contact with the ground where the foundations are insulated from the exterior according to Clause 3.2.3.3.(2)(a)**



	 <p>The ground should be adequately drained.</p> <p>1.2 m or total area</p> <p><b>Figure A-3.2.3.3.-D</b>  <b>Insulation of floors in contact with the ground for a slab-on-ground with integrated footings according to Sentence 3.2.3.3.(3)</b></p>
A-3.2.4.2.(1)	Strike out the Note.
A-3.2.4.3.(1) and (2)	Strike out the Note.
	<p>Add the following Note:</p> <p><b>“A-3.2.4.3.(9) Vestibule doors.</b> Main entry doors that are part of a complete air barrier system, such as interior and exterior doors of a vestibule, may be tested as an entire assembly.”</p>
A-3.3.1.1.(6)	Strike out the Note.
	<p>Add the following Notes:</p> <p><b>“A-3.3.1.2. Limitations.</b> The trade-off path described in Section 3.3. allows the designer to offset the non-compliance with the prescriptive requirements of certain above-ground building assemblies of the building envelope by considering the</p>

enhanced performance, i.e. higher than the prescriptive requirements, of other above-ground building assemblies of the envelope. For example, on the basis of the demonstration required in Section 3.3., it would be possible for a designer to offset the lower energy performance of a structural glazing by enhancing the energy performance of other windows of the building above the prescriptive requirements of Section 3.2. Simpler than the building energy performance compliance path detailed in Part 8, the trade-off path is limited to certain components of the building envelope.

**A-3.3.1.3.(1) Trade-off.** The trade-off path is based on the comparison of the steady-state energy performance of above-ground building assemblies of the proposed building envelope, i.e. the building as in the plans and specifications, with that of a reference building: an identical building except its envelope, completely in conformity with the prescriptive requirements of Section 3.2. The area of each above-ground building assembly ( $A_i$ ), including doors and fenestration, must be identical for the reference building and the proposed building. For opaque building assemblies of buildings that do not comply with the prescriptive requirements respecting the continuity of the insulation specified in Sentences 3.2.1.2.(1) to (7) and (10), the effective thermal resistance must be derated in accordance with Sentence (2).

**A-3.3.1.3.(2) Derating of the Effective Thermal Resistance.** The “derated” effective thermal resistance of opaque building assemblies of the envelope is generated from their effective thermal resistance calculated in accordance with Article 3.1.1.5. It must be derated to account for additional energy losses at the site of intersections and point penetrations of the envelope that do not comply with the continuity of insulation requirements in Sentences 3.2.1.2.(3) to (7) and (10). The intersections most often encountered in buildings are those of opaque building assemblies with parapets, foundations, intermediate floors and projections (such as cantilevered balconies).

Whereas the prescriptive requirements of those intersections or penetrations are descriptive in nature (see Sentences 3.2.1.2.(3) to (7) and (10)), the trade-off requires to quantify heat losses in relation to those intersections and penetrations where the prescriptive requirements are not complied with.

The derating of the effective thermal resistance of opaque building assemblies may be considered only if it is possible to characterize the parameters of the equation in Sentence 3.3.1.3.(2), whose values may be lower or higher than the prescriptive requirements, from recognized paths, in particular those in Articles 3.1.1.5. and 3.1.1.6.

The linear thermal transmittance of an intersection and the point thermal transmittance of a penetration may be obtained, for example, from laboratory tests or generated using digital heat transfer simulations (see the digital simulations in the research project of ASHRAE RP-1365, “Thermal Performance of Building Envelope Details for Mid- and High-Rise Buildings” provided as a reference in the “ASHRAE Handbook – Fundamentals” or the “Building Envelope Thermal Bridging Guide” by Morrison Hershfield). Point penetrations of the envelope and the wall/roof, wall/foundation, wall/projection and wall/intermediate floor intersections of the reference building must be characterized by the default values in Table 3.3.1.3.(3)-A and 3.3.1.3.-B.

	<p><b>A-3.3.1.3.(3) Linear Thermal Transmittance and Point Thermal Transmittance by Default of Certain Intersections and Penetrations of the Reference Building.</b> Where the derating of the effective thermal resistance of opaque building assemblies is required, in accordance with the requirement in Clause 3.3.1.3.(2), the method of trade-offs allows the application of the coefficients provided for in Tables 3.3.1.3-A and 3.3.1.3.-B.</p> <p><b>A-3.4.1.2. Limitations.</b> The performance path allows to offset the non-compliance with the prescriptive requirements of the building assemblies of the envelope considered in Sentence 3.4.1.2.(1) by improving the performance of the lighting systems, the HVAC systems, service water heating systems and building assemblies of the envelope considered in Sentence 3.4.1.2.(1). As with the trade-off path, the performance exchanges with the building assemblies of the envelope may only be considered if it is possible to characterize the thermal performance of those assemblies in accordance with Articles 3.1.1.5. and 3.1.1.6.</p> <p>The performance path offers the designer more flexibility than the trade-off path since it allows performance exchanges between the various systems of the building. Quantification of exchanges, to be carried out to demonstrate compliance of the building by the performance path, is performed using a building energy model that is described and standardized in Part 8. Contrary to the trade-off path, the performance path allows consideration of a fenestration area greater than 40%, and heat exchanges of building assemblies in contact with the ground, except as provided in Sentence 8.4.3.3.(7) (See Note A-8.4.3.3.(7)).”.</p>
<p><b>Division B Part 4</b></p>	
<p><b>4.1.1.2.</b></p>	<p>Replace Sentence (2) by the following:</p> <p>“2) This Part does not apply to the following lighting systems:</p> <p>a) emergency lighting that is automatically off during normal hours of <i>building</i> operation, and</p> <p>b) lighting within <i>dwelling units</i> (see Note A-4.1.1.2.(2)(b)).”.</p>
<p><b>4.2.1.3.</b></p>	<p>Replace the Article by the following:</p> <p>“<b>4.2.1.3. Limits to Installed Interior Lighting Power</b></p> <p>(See Note A-4.2.1.3.)</p> <p>1) Each space of the <i>building</i> shall appear in a space assembly considered in Sentence (3), except where the <i>building</i> has only one space, in which case the space is deemed to comply with Clauses (2)(a) and (2)(b).</p> <p>2) The space assembly considered in Sentence (3) shall</p> <p>a) be composed of more than one space,</p> <p>b) be composed of adjacent or superposed spaces, and</p> <p>c) except as provided in Sentence (4), correspond to a function in Table 4.2.1.5.</p>

	<p><b>3)</b> Except as provided in Sentence (6), the <i>installed interior lighting power</i> calculated in Article 4.2.1.4. for a space assembly shall not exceed the <i>interior lighting power allowance</i> for that assembly, calculated in accordance with one of the following methods:</p> <ul style="list-style-type: none"> <li>a) the <i>building area</i> method described in Article 4.2.1.5., or</li> <li>b) the <i>space-by-space</i> method described in Article 4.2.1.6.</li> </ul> <p><b>4)</b> The <i>interior lighting power allowance</i> of the <i>building</i> shall be calculated using the <i>space-by-space</i> method described in Article 4.2.1.6. in the following cases:</p> <ul style="list-style-type: none"> <li>a) where the space assembly considered in Sentence (1) corresponds to a function different than those in Table 4.2.1.5., or</li> <li>b) where a space cannot be included in a space assembly in conformity with Sentence (2).</li> </ul> <p><b>5)</b> The <i>installed interior lighting power</i> of a space may exceed the <i>interior lighting power allowance</i> of that space, the transfer of power between spaces of the same assembly being permitted. (See Note A-4.2.1.3.(5).)</p> <p><b>6)</b> Where a <i>building</i> has several space assemblies, the <i>installed interior lighting power</i> of a space assembly may exceed the <i>interior lighting power allowance</i> of that space assembly, the transfer of power between space assemblies being permitted on the following conditions:</p> <ul style="list-style-type: none"> <li>a) only one of the methods described in Sentence (3) is used for all the spaces considered,</li> <li>b) one of the following conditions is met: <ul style="list-style-type: none"> <li>i) electrical inputs for all the spaces considered are connected to the same electric meter, or</li> <li>ii) all the spaces considered are intended to be occupied by the same occupant, and</li> </ul> </li> <li>c) except as provided in Sentence 4.2.1.6.(8), the <i>interior lighting power allowance</i> for all the spaces considered is not exceeded.</li> </ul> <p>(See Note A-4.2.1.3.(6).)”.</p>
4.2.1.4.	<p>Add “(See Note A-4.2.1.4.)” after “<b>4.2.1.4. Determination of the Installed Interior Lighting Power</b>”;</p> <hr/> <p>Replace “Except as provided in Sentences (4) and (5)” in Sentence (1) by “Except as provided in Sentence (4)”;</p> <hr/> <p>Strike out “by ceiling-height <i>partitions</i>” in Clause (4)(g);</p> <hr/> <p>Replace Clause (4)(k) by the following:</p> <p>“k) lighting of devices that are for sale or for educational demonstration systems (see Note A-4.2.1.4.(4)(k)),”;</p> <hr/>

	<p>Replace Clauses (4)(o) and (4)(p) by the following:</p> <p>“o) mirror lighting in dressing rooms,  p) accent lighting in religious pulpit and choir areas,  q) lighting for covered vehicle entrances and <i>exits</i> from <i>storage garages</i>, and  r) lighting of work areas integrated to the furniture.”;</p> <hr/> <p>Strike out Sentence (5).</p>																										
4.2.1.5.	<p>Replace the Article by the following:</p> <p><b>“4.2.1.5. Calculation of Interior Lighting Power Allowance Using the Building Area Method</b></p> <p>(See Note A-4.2.1.5.)</p> <p><b>1)</b> Calculation of the <i>interior lighting power allowance</i> for the space assembly described in Sentence 4.2.1.3.(2) using the <i>building area</i> method shall be carried out as follows:</p> <p>a) the <i>floor surface area</i> shall be determined for that space assembly,  b) the lighting power density (LPD) allowed for the <i>floor surface area</i> determined in accordance with Clause (a) shall be determined from Table 4.2.1.5. for the specific function, and  c) the <i>interior lighting power allowance</i> of the space assembly shall be calculated by multiplying the <i>floor surface area</i> determined in Clause (a) by the allowed LPD determined in Clause (b).</p> <p style="text-align: center;"><b>Table 4.2.1.5.</b>  <b>Lighting Power Density (LPD) Allowed According to the Function for Use with the Building Area Method</b></p> <p style="text-align: center;">Forming Part of Sentences 4.2.1.3.(2) to (4) and 4.2.1.5.(1)</p> <table border="1" data-bbox="452 1076 1241 1645"> <thead> <tr> <th style="text-align: center;">Function</th> <th style="text-align: center;">Lighting Power Density, W/m<sup>2</sup></th> </tr> </thead> <tbody> <tr> <td>Automobile facility</td> <td style="text-align: center;">8.6</td> </tr> <tr> <td>Convention centre</td> <td style="text-align: center;">10.9</td> </tr> <tr> <td>Courthouse</td> <td style="text-align: center;">10.9</td> </tr> <tr> <td>Dining:</td> <td></td> </tr> <tr> <td style="padding-left: 20px;">bar lounge/leisure</td> <td style="text-align: center;">10.9</td> </tr> <tr> <td style="padding-left: 20px;">cafeteria/fast food</td> <td style="text-align: center;">9.7</td> </tr> <tr> <td style="padding-left: 20px;">family</td> <td style="text-align: center;">10.2</td> </tr> <tr> <td>Dormitory</td> <td style="text-align: center;">6.1</td> </tr> <tr> <td>Exercise centre</td> <td style="text-align: center;">9.0</td> </tr> <tr> <td>Fire station</td> <td style="text-align: center;">7.2</td> </tr> <tr> <td>Gymnasium</td> <td style="text-align: center;">10.1</td> </tr> <tr> <td>Health care clinic</td> <td style="text-align: center;">9.7</td> </tr> </tbody> </table>	Function	Lighting Power Density, W/m <sup>2</sup>	Automobile facility	8.6	Convention centre	10.9	Courthouse	10.9	Dining:		bar lounge/leisure	10.9	cafeteria/fast food	9.7	family	10.2	Dormitory	6.1	Exercise centre	9.0	Fire station	7.2	Gymnasium	10.1	Health care clinic	9.7
Function	Lighting Power Density, W/m <sup>2</sup>																										
Automobile facility	8.6																										
Convention centre	10.9																										
Courthouse	10.9																										
Dining:																											
bar lounge/leisure	10.9																										
cafeteria/fast food	9.7																										
family	10.2																										
Dormitory	6.1																										
Exercise centre	9.0																										
Fire station	7.2																										
Gymnasium	10.1																										
Health care clinic	9.7																										

	<table border="1"> <tbody> <tr> <td>Hospital</td> <td>11.3</td> </tr> <tr> <td>Hotel/motel</td> <td>9.4</td> </tr> <tr> <td>Library</td> <td>12.8</td> </tr> <tr> <td>Manufacturing facility</td> <td>12.6</td> </tr> <tr> <td>Motion picture <i>theatre</i></td> <td>8.2</td> </tr> <tr> <td>Multi-unit residential <i>building</i></td> <td>5.5</td> </tr> <tr> <td>Museum</td> <td>11.0</td> </tr> <tr> <td>Office</td> <td>8.8</td> </tr> <tr> <td>Penitentiary</td> <td>8.7</td> </tr> <tr> <td>Performing arts <i>theatre</i></td> <td>14.9</td> </tr> <tr> <td>Police station</td> <td>9.4</td> </tr> <tr> <td>Post office</td> <td>9.4</td> </tr> <tr> <td>Religious <i>building</i></td> <td>10.8</td> </tr> <tr> <td>Retail area</td> <td>13.5</td> </tr> <tr> <td>School/university</td> <td>9.4</td> </tr> <tr> <td>Sports arena</td> <td>9.8</td> </tr> <tr> <td><i>Storage garage</i></td> <td>2.3</td> </tr> <tr> <td>Town hall</td> <td>9.6</td> </tr> <tr> <td>Transportation facility</td> <td>7.5</td> </tr> <tr> <td>Warehouse</td> <td>7.1</td> </tr> <tr> <td>Workshop</td> <td>12.8</td> </tr> </tbody> </table>	Hospital	11.3	Hotel/motel	9.4	Library	12.8	Manufacturing facility	12.6	Motion picture <i>theatre</i>	8.2	Multi-unit residential <i>building</i>	5.5	Museum	11.0	Office	8.8	Penitentiary	8.7	Performing arts <i>theatre</i>	14.9	Police station	9.4	Post office	9.4	Religious <i>building</i>	10.8	Retail area	13.5	School/university	9.4	Sports arena	9.8	<i>Storage garage</i>	2.3	Town hall	9.6	Transportation facility	7.5	Warehouse	7.1	Workshop	12.8
Hospital	11.3																																										
Hotel/motel	9.4																																										
Library	12.8																																										
Manufacturing facility	12.6																																										
Motion picture <i>theatre</i>	8.2																																										
Multi-unit residential <i>building</i>	5.5																																										
Museum	11.0																																										
Office	8.8																																										
Penitentiary	8.7																																										
Performing arts <i>theatre</i>	14.9																																										
Police station	9.4																																										
Post office	9.4																																										
Religious <i>building</i>	10.8																																										
Retail area	13.5																																										
School/university	9.4																																										
Sports arena	9.8																																										
<i>Storage garage</i>	2.3																																										
Town hall	9.6																																										
Transportation facility	7.5																																										
Warehouse	7.1																																										
Workshop	12.8																																										
	”.																																										
<b>4.2.1.6.</b>	<p>Replace Sentence (1) by the following:</p> <p>“<b>1)</b> The <i>interior lighting power allowance</i> using the space-by-space method shall be determined as follows:</p> <ol style="list-style-type: none"> <li>the <i>floor surface area</i> of each space of the assembly shall be determined,</li> <li>the allowed lighting power density (LPD) for each space shall be determined using Table 4.2.1.6. for the exact space type or a space type that most closely represents the proposed use of each space,</li> <li>the <i>interior lighting power allowance</i> for each space shall be calculated by multiplying the <i>floor surface area</i> determined in Clause (a) by the allowed LPD determined in Clause (b), and</li> </ol>																																										



	<p>d) the <i>interior lighting power allowance</i> of the <i>building</i> shall be calculated by summing the <i>interior lighting power allowance</i> for each space determined in Clause (c).</p> <p><b>2)</b> Where the use of a space corresponds to more than one type provided for in Table 4.2.1.6., not dividing the space is permitted provided that the type described in Table 4.2.1.6. represents a <i>floor surface area</i> of</p> <p>a) less than 20% of the space, for a space having a <i>floor surface area</i> of not more than 1500 m<sup>2</sup>, or</p> <p>b) less than 300 m<sup>2</sup>, for a space having a <i>floor surface area</i> of more than 1500 m<sup>2</sup>.</p> <p><b>3)</b> Increasing by 20% the <i>interior lighting power allowance</i> of a space other than an atrium, calculated in accordance with Clause (1)(c), is permitted where the space adjustment factor, AF, calculated using the following equation, is greater than the value referred to in Table 4.2.1.6.:</p> $AF = 2.5 \times (H_1 - H_2) \times L / S$ <p>where</p> <p>H<sub>1</sub> = height of luminaires in relation to the floor, in m,</p> <p>H<sub>2</sub> = height of work surface in relation to the floor, in m,</p> <p>L = perimeter of the <i>floor surface area</i> of the space, in m, and</p> <p>S = <i>floor surface area</i> of the space, in m<sup>2</sup>.</p> <p>(See Note A-4.2.1.6.(3).)</p> <p><b>4)</b> Increasing by 20% the <i>interior lighting power allowance</i> of a corridor or transition area is permitted where the width of the space is less than 2.4 m. (See Note A-4.2.1.6.(4).)</p> <p><b>5)</b> Where lighting of a portion of a space is controlled by the type of control listed in Table 4.2.1.6. separately from the <i>general lighting</i> of the space, increasing the <i>interior lighting power allowance</i> of that portion of space by additional power, P<sub>additional</sub>, in W, calculated using the following equation, is permitted:</p> $P_{\text{additional}} = IILP_{\text{portion}} \times PI_{\text{LPD}}$ <p>where</p> <p>IILP<sub>portion</sub> = <i>installed interior lighting power</i> of the portion of the space concerned, in W, and</p> <p>PI<sub>LPD</sub> = percentage of increase of allowed LPD indicated in Table 4.2.1.6.</p> <p>(See Note A-4.2.1.6.(5).)</p> <p><b>6)</b> Where decorative lighting or lighting for displaying works of art or artefacts is controlled separately from the <i>general lighting</i> of the space, increasing the <i>interior lighting power allowance</i> of that portion of space by 10.8 W/m<sup>2</sup> is permitted. (See Note A-4.2.1.6.(6).)</p> <p><b>7)</b> Where lighting for displaying items for sale is controlled separately from the <i>general lighting</i> of the space, increasing the <i>interior lighting power allowance</i> of that portion of space by additional power P<sub>additional</sub>, in W, calculated using the following equation, is permitted:</p> $P_{\text{additional}} = 1000 \text{ W} + (A_1 \times 27 \text{ W/m}^2) + (A_2 \times 15 \text{ W/m}^2) + (A_3 \times 6.5 \text{ W/m}^2)$
--	---

	<p>where</p> <p><math>A_1</math> = areas reserved for displaying jewelry or crockery, including a traffic area having a width of not more than 900 mm, in m<sup>2</sup>,</p> <p><math>A_2</math> = areas reserved for displaying furniture, clothing, cosmetics or works of art for sale, including a traffic area having a width of not more than 900 mm, in m<sup>2</sup>, and</p> <p><math>A_3</math> = areas reserved for displaying any other item for sale, including a traffic area having a width of not more than 900 mm, in m<sup>2</sup>.</p> <p>(See Note A-4.2.1.6.(7).)</p> <p><b>8)</b> Except for the additional power listed in Sentences (6) and (7), the transfer of unused additional power listed in this Article to increase the <i>interior lighting power allowance</i> of another space in accordance with Sentence 4.2.1.3.(6) is permitted.”;</p> <hr/> <p>Replace Table 4.2.1.6. by the following:</p>
--	--

<sup>14</sup>Table 4.2.1.6. Allowed Lighting Power Density (LPD) for Use with the Space-by-Space Method, Adjustment Factor (AF) and Allowed Additional Lighting Power Density Forming Part of Sentences 4.2.1.6.(1), (2) and (3), and 4.2.2.1.(2), (10), (12) and (14)

Space Type	Lighting Power Density (LPD), W/m <sup>2</sup>	Adjustment Factor (AF)	Percentage of Increase of Allowed LPD (P <sub>LPD</sub> ) <sup>(2)</sup>	Type of Lighting Control <sup>(1)</sup>						
				Manual (see 4.2.2.1.(3))	Restricted to Manual ON (see 4.2.2.1.(6))	Restricted to Partial Automatic ON <sup>(8)</sup> (see 4.2.2.1.(8))	Bi-Level (see 4.2.2.1.(9))	Automatic Partial OFF (see 4.2.2.1.(10))	Automatic Full OFF <sup>(9)</sup> (see 4.2.2.1.(12))	Scheduled Shut-off (see 4.2.2.1.(14))
<b>Common Space Types<sup>(5)</sup></b>										
Atrium										
< 6 m in height	1.06 per m (height)	n/a	10% where C2	X	A	A	—	—	B	B
≥ 6 m and ≤ 12 m in height	1.06 per m (height)	n/a	10% where C2	X	A	A	X	—	B	B
> 12 m in height	4.3 + 0.71 per m (height)	n/a	10% where C2	X	A	A	X	—	B	B
Audience seating area—permanent										
for auditorium	6.8	6	n/a	X	A	A	X	—	B	B
for convention centre	8.9	4	n/a	X	A	A	X	—	B	B
for gymnasium	7.0	6	n/a	X	A	A	X	—	B	B
for motion picture theatre	12.3	4	n/a	X	A	A	X	—	B	B
for penitentiary	3.0	4	n/a	X	A	A	—	—	B	B
for performing arts theatre	26.2	8	n/a	X	A	A	X	—	B	B
for religious building	16.5	4	n/a	X	A	A	X	—	B	B
for sports arena	4.6	4	n/a	X	A	A	—	—	B	B
other	4.6	4	n/a	X	A	A	—	—	B	B

Space Type	Lighting Power Density (LPD), W/m <sup>2</sup>	Adjustment Factor (AF)	Percentage of Increase of Allowed LPD (PL <sub>inc</sub> ) <sup>(2)</sup>	Type of Lighting Control <sup>(1)</sup>						Scheduled Shut-off (see 4.2.2.1 (14))
				Manual (see 4.2.2.1 (3))	Restricted to Manual ON (see 4.2.2.1 (6))	Restricted to Partial Automatic ON <sup>(3)</sup> (see 4.2.2.1 (8))	Bi-Level (see 4.2.2.1 (9))	Automatic Partial OFF (see 4.2.2.1 (10))	Automatic Full OFF <sup>(6)</sup> (see 4.2.2.1 (12))	
Banking activity area and offices	10.9	6	n/a	X	A	A	X	—	B	B
Classroom/Lecture hall/Training room										
for penitentiary	14.5	4	10% where C1 or C2	X	A	A	X	—	X	—
other	13.4	4	10% where C1 or C2	X	A	A	X	—	X	—
Conference/Meeting/Multi-purpose room	13.3	6	10% where C1 or C2	X	A	A	X	—	X	—
Confinement cell	8.8	6	n/a	X	A	A	X	—	B	B
Copy/Print room	7.8	6	n/a	X	A	A	X	—	X	—
Corridor and transition area										
for hospital	10.7	Width < 2.4 m (see 4.2.1.6.(4))	10% where C2	X	—	—	—	B	B	B
for manufacturing facility	4.4	Width < 2.4 m (see 4.2.1.6.(4))	10% where C2	X	—	—	—	—	B	B
for space designed to ANSI/IES RP-28, "Lighting and the Visual Environment for Senior Living" (and used primarily by residents)	9.9	Width < 2.4 m (see 4.2.1.6.(4))	10% where C2	X	—	—	—	X	B	B
other	7.1	Width < 2.4 m (see 4.2.1.6.(4))	10% where C2	X	—	—	—	X	B	B
Courtroom	18.6	6	10% where C1 or C2	X	A	A	X	—	B	B

Space Type	Lighting Power Density (LPD), W/m <sup>2</sup>	Adjustment Factor (AF)	Percentage of Increase of Allowed LPD (P <sub>Linc</sub> ) <sup>(2)</sup>	Type of Lighting Control <sup>(1)</sup>						Scheduled Shut-off (see 4.2.2.1.(14))
				Manual (see 4.2.2.1.(3))	Restricted to Manual ON (see 4.2.2.1.(6))	Restricted to Partial Automatic ON <sup>(3)</sup> (see 4.2.2.1.(8))	Bi-Level (see 4.2.2.1.(9))	Automatic Partial OFF (see 4.2.2.1.(10))	Automatic Full OFF <sup>(4)</sup> (see 4.2.2.1.(12))	
Dining area for bar lounge/leisure dining	11.6	4	10% where C2	X	A	A	X	-	B	B
for cafe/tea/fast food dining	7.0	4	10% where C2	X	A	A	X	-	B	B
for family dining	9.6	4	10% where C2	X	A	A	X	-	B	B
for penitentiary	10.3	6	10% where C2	X	A	A	X	-	B	B
for spaces designed to ANS/IES RP-28, "Lighting and the Visual Environment for Senior Living" (and used primarily by residents)	28.5	4	10% where C2	X	A	A	X	-	B	B
other	7.0	4	10% where C2	X	A	A	X	-	B	B
Dressing/Fitting room for performing arts – <i>theatre</i>	6.6	6	n/a	X	A	A	X	-	X	-
Electrical or mechanical room	4.6	6	124% <sup>(6)</sup>	X	-	-	-	-	-	-
Emergency vehicle garage	6.1	4	10% where C2	X	A	A	-	-	B	B
Food preparation area	13.1	6	n/a	X	A	A	X	-	B	B
Guest room	5.1	6	n/a	See Sentence 4.2.2.6.(2)						
Laboratory for classroom	15.5	6	n/a	X	A	A	X	X	B	B
other	19.5	6	n/a	X	A	A	X	-	B	B

Space Type	Lighting Power Density (LPD), W/m <sup>2</sup>	Adjustment Factor (AF)	Percentage of Increase of Allowed LPD (P <sub>(L,ns)</sub> ) <sup>(1)</sup>	Type of Lighting Control <sup>(1)</sup>						Scheduled Shut-off (see 4.2.2.1.(14))
				Manual (see 4.2.2.1.(3))	Restricted to Manual ON (see 4.2.2.1.(6))	Restricted to Partial Automatic ON <sup>(3)</sup> (see 4.2.2.1.(8))	Bi-Level (see 4.2.2.1.(9))	Automatic Partial OFF (see 4.2.2.1.(10))	Automatic Full OFF <sup>(4)</sup> (see 4.2.2.1.(12))	
Laundry/washing area	6.5	4	n/a	X	A	A	X	-	B	B
Loading dock — interior	5.1	6	n/a	X	A	A	-	-	B	B
Lobby										
for elevator	7.0	6	10% where C2	X	-	-	-	-	B	B
for hotel	11.5	4	10% where C2	X	-	-	-	-	B	B
for motion picture <i>theatre</i>	6.4	4	10% where C2	X	-	-	-	-	B	B
for performing arts <i>theatre</i>	21.6	6	10% where C2	X	-	-	-	X	B	B
for space designed to ANS/IES RP-28: "Lighting and the Visual Environment for Senior Living" (and used primarily by residents)	19.4	4	10% where C2	X	-	-	-	X	B	B
other	9.7	4	10% where C2	X	-	-	-	X	B	B
Locker room	8.1	6	n/a	X	A	A	X	-	X	-
Lounge or break room										
for health care facility	10.0	6	n/a	X	A	A	X	-	X	-
other	7.9	4	n/a	X	A	A	X	-	X	-

Space Type	Lighting Power Density (LPD), W/m <sup>2</sup>	Adjustment Factor (AF)	Percentage of Increase of Allowed LPD (P <sub>L,LPD</sub> ) <sup>(1)</sup>	Type of Lighting Control <sup>(1)</sup>						Scheduled Shut-Off (see 4.2.2.1.(14))	
				Manual (see 4.2.2.1.(3))	Restricted to Manual ON (see 4.2.2.1.(6))	Restricted to Partial Automatic ON <sup>(3)</sup> (see 4.2.2.1.(6))	Bi-Level (see 4.2.2.1.(9))	Automatic Partial OFF (see 4.2.2.1.(10))	Automatic Full OFF <sup>(4)</sup> (see 4.2.2.1.(12))		
Office											
open plan	10.6	4	5% where C1 or C2 25% where C3 30% where C4	X	A	A	X	-	B	B	
enclosed, ≤ 25 m <sup>2</sup>	12.0	8	5% where C1 or C2	X	A	A	X	-	X	-	
enclosed, > 25 m <sup>2</sup>	12.0	8	5% where C1 or C2	X	A	A	X	-	B	B	
Pharmacy area	18.1	6	n/a	X	A	A	X	-	B	B	
Sales area	15.5	6	n/a	X	A	A	X	-	B	B	
Seating area	5.9	4	n/a	X	A	A	-	-	B	B	
Computer/Server room	18.4	4	n/a	X	A	A	X	-	B	B	
Stairway, except stairwell	The control and lighting power density requirements shall be the same as those for the space containing the stairway.										
Stairwell	7.4	10	10% where C2	X	-	-	X	X	B	B	
Storage garage – interior	2.1	4	10% where C2	See Article 4.2.2.2.						B	B

Storage room	< 5 m <sup>2</sup>	13.3	6	n/a	X	-	-	-	-	-	B	B
	≥ 5 m <sup>2</sup> and ≤ 100 m <sup>2</sup>	6.8	6	n/a	X	A	A	-	-	-	X	-
	> 100 m <sup>2</sup>	6.8	6	n/a	X	A	A	-	X	-	B	B
Vehicle maintenance area	7.3	4	n/a	X	A	A	A	X	-	-	B	B
Washroom												
for space designed to ANSI/IES RP-28 "Lighting and the Visual Environment for Senior Living" (and used primarily by residents)	13.1	8	n/a	X	-	-	-	-	-	-	X	-
other	10.5	8	n/a	X	-	-	-	-	-	-	X	-
Workshop	17.2	6	n/a	X	A	A	A	X	-	-	B	B
<b>Building-Specific Space Types<sup>(5)</sup></b>												
Convention centre – exhibit space	15.7	4	n/a	X	A	A	A	X	-	-	B	B
Dormitory – living quarters	4.2	8	n/a	X	-	-	-	-	-	-	-	-
Fire station – sleeping quarters	2.4	6	n/a	X	-	-	-	-	-	-	-	-
Gymnasium/Fitness centre												
exercise area	7.8	4	10% where C2	X	A	A	A	X	-	-	B	B
playing area	13.0	4	10% where C2	X	A	A	A	X	-	-	B	B
Health care facility												
exam/treatment room	18.0	8	n/a	X	-	-	-	X	-	-	B	B
imaging room	16.3	6	n/a	X	-	-	-	X	-	-	B	B



		See 'Storage Room' under Common Space Types for applicable control requirements.									
medical supply room	8.0	6	n/a	X	-	-	-	X	-	-	B
nursery	9.5	6	n/a	X	-	-	-	X	-	-	B
nurses' station	7.6	6	n/a	X	-	-	-	X	-	-	B
operating room	26.8	6	n/a	X	-	-	-	X	-	-	B
patient room	6.7	6	n/a	X	-	-	-	X	-	-	B
physical therapy room	9.9	6	n/a	X	-	-	-	X	-	-	B
recovery room	12.4	6	n/a	X	-	-	-	X	-	-	B
Library											
reading area	11.5	4	n/a	X	A	A	A	X	-	-	B
stacks	18.4	4	n/a	X	A	A	A	X	X	X	B
Manufacturing facility											
detailed manufacturing area	13.9	4	n/a	X	A	A	A	X	-	-	B
equipment room	8.0	6	n/a	X	A	A	A	X	-	-	B
extra high bay area (> 15 m floor-to-ceiling)	11.3	4	n/a	X	A	A	A	X	-	-	B
high bay area (7.5 m to 15 m floor-to-ceiling height)	13.3	4	n/a	X	A	A	A	X	-	-	B
low bay area (< 7.5 m floor-to-ceiling height)	12.9	4	n/a	X	A	A	A	X	-	-	B
Museum											
general exhibition area	11.4	6	n/a	X	A	A	A	X	-	-	B
restoration room	11.0	6	n/a	X	A	A	A	X	-	-	B

Post office – sorting area	10.2	4	n/a	X	A	A	X	X		B	B
Religious building											
fellowship hall	6.9	4	n/a	X	A	A	X	X		B	B
worship/pulpit/choir area	16.5	4	n/a	X	A	A	X	X		B	B
Retail facility											
dressing/fitting room	7.7	8	n/a	X	A	A	X	X		X	–
mall concourse	11.9	4	10% where C2	X	A	A	X	X		B	B
Space designed to ANS/IES RP-28, "Lighting and the Visual Environment for Senior Living"											
chapel (used primarily by residents)	23.8	4	n/a	X	A	A	X	X		B	B
recreation room (used primarily by residents)	25.9	6	n/a	X	A	A	X	X		B	B
Sports arena – playing area											
playing area with facilities for more than 5000 spectators	39.7	4	n/a	X	A	A	X	X		B	B
playing area with facilities for more than 2000 spectators and not more than 5000 spectators	25.9	4	n/a	X	A	A	X	X		B	B
playing area with facilities for more than 200 spectators and not more than 2000 spectators	19.4	4	n/a	X	A	A	X	X		B	B

playing area with facilities for less than 200 spectators or without a facility for spectators	13.0	4	n/a	X	A	A	X	-	B	B
<b>Transportation facility</b>										
airport concourse	3.9	4	n/a	X	A	A	-	-	B	B
baggage/carousel area	5.7	4	n/a	X	A	A	-	-	B	B
terminal ticket counter	8.7	4	n/a	X	A	A	X	-	B	B
<b>Warehouse – storage area</b>										
medium to bulky palletized items	6.2	4	n/a	X	A	A	X	X	B	B
small hand-carried items	10.2	6	n/a	X	A	A	X	X	B	B

**Notes to Table 4.2.1.6:**

- (1) Controls C1 to C4 designate the following controls:  
 C1: controls lighting using a manual dimmer;  
 C2: controls lighting using an hourly program for multiple lighting levels;  
 C3: controls lighting using occupant sensors, where the lighting meets the following criteria:  
 a) the lighting at each workstation is manually controlled;  
 b) the lighting at each workstation is automatically controlled;  
 c) the portion of the lighting directed towards the work surface is controlled independently from the portion directed toward the ceiling;  
 d) the lighting directed towards the work surface is turned off automatically by continuous dimming devices in the first 30 min of vacancy; dimming for turning off lighting shall last a minimum of 2 min.  
 e) at the arrival of the occupant, the portion of lighting directed towards the work surface turns on automatically to a first minimum lighting level, then by continuous dimming for at least 30 sec before reaching a preset higher level; and  
 f) the portion of lighting directed towards the ceiling meets the requirements of Sentence 4.2.2.1.(12);
- (2) C4: controls lighting using a C3 control, while permitting manual adjustment of the lighting level by continuous dimming of the lighting directed towards the work station.  
 n/a: not applicable;  
 A: at least one of the lighting controls marked with an "A" must be implemented in this space type;  
 B: at least one of the lighting controls marked with a "B" must be implemented in this space type;  
 X: all lighting controls marked with an "X" must be implemented in this space type; and  
 - (dash): this lighting control is not required to be implemented in this space type.
- (3) Controls meeting the requirements for "Partial Automatic ON" in Sentence 4.2.2.1.(8) also comply with the requirements for "Bi-Level" lighting control in Sentence 4.2.2.1.(9).
- (4) Controls meeting the requirements for "Automatic Full OFF" in Sentence 4.2.2.1.(12) also comply with the requirements for "Automatic Partial OFF" lighting control in Sentence 4.2.2.1.(10).
- (5) In cases where a space type is listed both as a common space type and a building-specific space type, the requirements for the building-specific space type apply. See Note A-Table 4.2.1.6.
- (6) An additional LPD of 5.7 W/m<sup>2</sup> is permitted, provided that the additional lighting is separately controlled from the lighting whose allowed LPD is 4.6 W/m<sup>2</sup>.
- (8)

<b>4.2.2.1.</b>	<p>Replace Sentence (1) by the following:</p> <p><b>"1)</b> Except as provided in Sentence (2), <i>interior lighting</i> control devices shall be installed in accordance with this Article for each space type in the <i>building</i>.”;</p> <hr/> <p>Replace “LPD” in the French text of Sentence (2) by “DPE”;</p> <hr/> <p>Replace Sentences (10) to (23) by the following:</p> <p><b>"10)</b> Except as provided in Sentence (11), the <i>general lighting</i> in spaces requiring controls that are “Automatic Partial OFF” in accordance with Table 4.2.1.6. shall automatically be reduced by 50% or more within 20 min of the space being unoccupied.</p> <p><b>11)</b> <i>General lighting</i> need not be controlled in accordance with Sentence (10) where</p> <ol style="list-style-type: none"> <li>a) the lighting power density for the space is not greater than 8.6 W/m<sup>2</sup>,</li> <li>b) the space is lit by high-intensity discharge (HID) lamps, and</li> <li>c) the power for the <i>general lighting</i> in the space is automatically reduced by 30% or more within 20 min of the space being unoccupied.</li> </ol> <p><b>12)</b> Except as provided in Sentence (13), the lighting in spaces requiring controls that are "Automatic Full OFF" in accordance with Table 4.2.1.6. shall be controlled by automatic control devices that shut off the lighting within 20 min of the space being unoccupied, where each automatic control device controls an area not greater than 500 m<sup>2</sup>.</p> <p><b>13)</b> The following lighting applications need not comply with Sentence (12):</p> <ol style="list-style-type: none"> <li>a) <i>general lighting</i> and task lighting in shop and laboratory classrooms,</li> <li>b) <i>general lighting</i> and task lighting in spaces where automatic shut-off would endanger the safety or security of the <i>building</i> occupants, and</li> <li>c) lighting required to operate continuously due to operational requirements.</li> </ol> <p><b>14)</b> Except as provided in Sentence (17), the lighting in spaces requiring controls that are "Scheduled Shut-off" in accordance with Table 4.2.1.6. shall shut off automatically during periods when the spaces are scheduled to be unoccupied by means of control devices complying with Sentence (15) that are</p> <ol style="list-style-type: none"> <li>a) time-of-day operated to automatically turn the lighting off at programmed times, or</li> <li>b) signals from other automatic control devices or alarm/security systems.</li> </ol> <p><b>15)</b> A control device installed to meet the requirements of Sentence (14) shall</p> <ol style="list-style-type: none"> <li>a) control the lighting for an area of not more than 2500 m<sup>2</sup> on not more than one <i>storey</i>, and</li> <li>b) consider independently the operation during weekdays, weekends and holidays.</li> </ol> <p><b>16)</b> Any manual control device installed to override the “Scheduled Shut-off” control device required in Sentence (14) shall</p> <ol style="list-style-type: none"> <li>a) turn the lighting on for 2 h or less per activation during scheduled “off” periods, and</li> </ol>
-----------------	--

	<p>b) control an area of 500 m<sup>2</sup> or less.</p> <p><b>17)</b> The control in Sentence (14) is not required where it is</p> <p>a) required to operate continuously due to operational requirements,</p> <p>b) located in spaces where patient care is rendered, or</p> <p>c) located in spaces where automatic shut-off would endanger the safety or security of the <i>building</i> occupants.”.</p>
<b>4.2.2.2.</b>	<p>Replace Sentence (2) by the following:</p> <p>“<b>2)</b> Except as provided in Sentence (4), the lighting power in a zone referred to in Sentence (1) shall be controlled by a device that automatically reduces the power of each lighting device of the zone by at least 30% when no activity is detected for 20 min. (See Note A-4.2.2.2.(2).)”;</p> <hr/> <p>Replace Sentence (4) by the following:</p> <p>“<b>4)</b> Daylight transition zones and ramps without parking need not comply with the provisions of Sentences (1) and (2).”;</p> <hr/> <p>Strike out Sentence (5).</p>
<b>4.2.2.3.</b>	Strike out the Article.
<b>4.2.2.4.</b>	Strike out the Article.
<b>4.2.2.5.</b>	Strike out the Article.
<b>4.2.2.6.</b>	Replace “2 W” in Sentence (2) by “5 W”.
<b>4.2.3.1.</b>	<p>Strike out Sentence (2);</p> <hr/> <p>Replace Sentences (3) and (4) by the following:</p> <p>“<b>3)</b> Except as provided in Sentence (6), the installed <i>exterior lighting</i> power for each specific <i>building</i> exterior application listed in Table 4.2.3.1.-C that is to be illuminated shall not be greater than the allowance for the application concerned according to the applicable lighting zone plus any unused power from the basic site allowance listed in Table 4.2.3.1.-B. (See Note A-4.2.3.1.(3).)</p>

4) Except as provided in Sentence (6), the installed *exterior lighting* power for all general *building* exterior applications that are to be illuminated shall not be greater than the sum of the allowances for the applications provided in Table 4.2.3.1.-D according to the applicable lighting zone plus any unused power from the basic site allowance listed in Table 4.2.3.1.-B, the transfer of power between the applications being permitted.”;

Replace Table 4.2.3.1.-B by the following:

**“Table 4.2.3.1.-B  
Basic Site Allowances for Exterior Lighting  
Forming Part of Sentences 4.2.3.1.(3) and (4)**

Basic Site Allowances According to Lighting Zone				
Zone 0	Zone 1	Zone 2	Zone 3	Zone 4
No allowance	500 W	600 W	750 W	1300 W

”;

Replace Table 4.2.3.1.-C by the following:

**“Table 4.2.3.1.-C  
Lighting Power Allowances for Specific Building Exterior Applications  
Forming Part of Sentence 4.2.3.1.(3)**

Exterior Application	Lighting Power Allowances According to Lighting Zone				
	Zone 0	Zone 1	Zone 2	Zone 3	Zone 4
<i>Building facades (façade lighting)</i>	A single luminaire of 60 W or less may be installed for each roadway or parking entry, trail head, and toilet facility, or other locations approved by the <i>authority having jurisdiction</i>	No allowance	1.1 W/m <sup>2</sup> for each illuminated wall or surface, or 8.2 W/m for each illuminated wall or surface length	1.6 W/m <sup>2</sup> for each illuminated wall or surface, or 12.3 W/m for each illuminated wall or surface length	2.2 W/m <sup>2</sup> for each illuminated wall or surface, or 16.4 W/m for each illuminated wall or surface length
Automated teller machines (ATM) and night depositories		270 W per location plus 90 W per additional ATM per location			
Entrances and gatehouse inspection stations at guarded facilities		8.1 W/m <sup>2</sup> of covered and uncovered area			
Loading areas for law enforcement, fire, ambulance and other emergency		5.4 W/m <sup>2</sup> of covered and uncovered area			

service vehicles		
Drive-up windows and doors		400 W per drive-through
Parking near 24-hour retail establishment entrances		800 W per main entry

”;

Replace Table 4.2.3.1.-D by the following:

**“Table 4.2.3.1.-D  
Lighting Power Allowances for General Building Exterior Applications  
Forming Part of Sentence 4.2.3.1.(4)**

Exterior Application	Lighting Power Allowances According to Lighting Zone				
	Zone 0	Zone 1	Zone 2	Zone 3	Zone 4
Uncovered Parking Areas Parking areas and drives	No allowance	0.4 W/m <sup>2</sup>	0.7 W/m <sup>2</sup>	1.1 W/m <sup>2</sup>	1.4 W/m <sup>2</sup>
<i>Building Grounds</i> Walkways less than 3 m wide	No allowance	2.3 W/m	2.3 W/m	2.6 W/m	3.3 W/m
Walkways 3 m wide or greater, plaza areas, special feature areas		1.5 W/m <sup>2</sup>	1.5 W/m <sup>2</sup>	1.7 W/m <sup>2</sup>	2.2 W/m <sup>2</sup>
Stairways		8.1 W/m <sup>2</sup>	11.0 W/m <sup>2</sup>	11.0 W/m <sup>2</sup>	11.0 W/m <sup>2</sup>
Pedestrian tunnels		1.6 W/m <sup>2</sup>	1.6 W/m <sup>2</sup>	2.2 W/m <sup>2</sup>	3.2 W/m <sup>2</sup>
<i>Landscape lighting</i>		0.4 W/m <sup>2</sup>	0.5 W/m <sup>2</sup>	0.5 W/m <sup>2</sup>	0.5 W/m <sup>2</sup>
Exterior Entrances and Exterior Exits Main entries	No allowance	66 W/m of width	66 W/m of width	98 W/m of width	98 W/m of width
Other doors		66 W/m of width	66 W/m of width	66 W/m of width	66 W/m of width
Canopies		2.7 W/m <sup>2</sup>	2.7 W/m <sup>2</sup>	4.3 W/m <sup>2</sup>	4.3 W/m <sup>2</sup>

Sales Canopies Free-standing and attached	No allowance	6.5 W/m <sup>2</sup>	6.5 W/m <sup>2</sup>	8.6 W/m <sup>2</sup>	11.0 W/m <sup>2</sup>
Outdoor Sales Open areas (including vehicle sales lots)		2.7 W/m <sup>2</sup>	2.7 W/m <sup>2</sup>	5.4 W/m <sup>2</sup>	7.5 W/m <sup>2</sup>
Street frontage for vehicle sales lots in addition to "open area" allowance	No allowance	No allowance	33 W/m	33 W/m	98 W/m

”;  
,

---

Replace Sentence (5) by the following:

“**5**) Except as provided in Sentence (6), the installed *exterior lighting* power shall be determined in the same manner as the *installed interior lighting* power in accordance with Sentences 4.2.1.4.(1) to (3).”;

---

Replace “independent control device that complies with the requirements of Subsection 4.2.4.” in Sentence (6) by “autonomous control device”;

---

Replace Clause (6)(a) by the following:

“a) lighting of water fountains or lighting integral to swimming pools”;

---

Strike out “or instrumentation” in Clause (6)(c);

---

Replace Clauses (6)(h) and (6)(i) by the following:

“h) lighting for theme elements in theme/amusement parks,  
i) lighting used to highlight features of art objects, public monuments and designated national or provincial historic sites,  
k) temporary lighting, and  
l) lighting for searchlight.”.

**4.2.4.1.**

Replace the Article by the following:

**“4.2.4.1. Exterior Lighting Controls**

**1)** *Exterior lighting* shall be equipped with automatic shut-off controls based on daylight. (See Note A-4.2.4.1.(1).)



	<p><b>2) Facade lighting and landscape lighting</b> shall be equipped with shut-off controls that shut it off automatically for the period</p> <p>a) beginning not later than midnight or when the <i>building</i> closes, and</p> <p>b) ending no sooner than 6 a.m. or when the <i>building</i> opens.</p> <p><b>3) Exterior lighting, excluding facade lighting and landscape lighting,</b> shall be controlled by a device that automatically reduces the installed lighting power by at least 30% according to one of the following conditions:</p> <p>a) for the period</p> <p>i) beginning not later than midnight or 60 min after the <i>building</i> closes, and</p> <p>ii) ending no sooner than 6 a.m. or when the <i>building</i> opens, or</p> <p>b) during a 15-min period of inactivity.</p> <p><b>4) All lighting schedule controllers</b> shall be equipped with backup provisions to retain programming and the time setting for at least 10 h during a power outage.</p> <p><b>5) The following exterior lighting applications</b> need not comply with the requirements of Sentences (1) to (4):</p> <p>a) <i>exterior lighting</i> for covered vehicle entrances and exits from <i>storage garages</i>, and</p> <p>b) <i>exterior lighting</i> provided for in Clauses 4.2.3.1.(6)(b) to 6(d) and 4.2.3.1.(6)(j) and (6)(k).”.</p>
4.3.1.1.	Replace “lighting controls” in Sentence (1) by “photocontrols”.
4.3.1.2.	<p>Replace Sentence (1) by the following:</p> <p><b>“1) Exterior lighting and exterior lighting</b> controls shall comply with Subsections 4.2.3. and 4.2.4.</p> <p><b>2) Interior lighting</b> controls shall comply with Subsection 4.2.2.”.</p>
4.3.1.3.	<p>Replace the Article by the following:</p> <p><b>“4.3.1.3. Compliance</b></p> <p><b>1) Interior lighting</b> shall be deemed to comply with this Section where the installed <i>interior lighting</i> energy, IILE, in kW×h/a, of the proposed <i>building</i>, calculated in accordance with Subsection 4.3.2., does not exceed the <i>interior lighting</i> energy allowance, ILEA, in kW×h/a, calculated in accordance with Subsection 4.3.3.”.</p>

4.3.2.1.	<p>Replace the Article by the following:</p> <p><b>“4.3.2.1. Determination of Installed Interior Lighting Energy</b></p> <p>1) The installed <i>interior lighting</i> energy, IILE, in kW×h/a, which is the total <i>annual energy consumption</i> of <i>interior lighting</i> in all spaces of the proposed <i>building</i>, shall be calculated using the following equation:</p> $IILE = \sum_{i=1}^N E_{i,proposed}$ <p>where</p> <p>N = total number of spaces in the proposed <i>building</i>, and</p> <p><math>E_{i,proposed}</math> = <i>annual energy consumption</i> of <i>interior lighting</i> in space i, in kW×h/a, calculated in accordance with Sentence (2).</p> <p>2) The <i>annual energy consumption</i> of <i>interior lighting</i> in a space, <math>E_{i,proposed}</math>, in kW×h/a, shall be calculated using the following equation:</p> $E_{i,proposed} = LPD_{i,proposed} \times S_i \times t_i / 1000$ <p>where</p> <p><math>LPD_{i,proposed}</math> = proposed LPD of the lighting in space i, in W/m<sup>2</sup>, determined in accordance with Article 4.3.2.2.,</p> <p><math>S_i</math> = <i>floor surface area</i> of space i, in m<sup>2</sup>, and</p> <p><math>t_i</math> = annual operational time of space i, in h/a, determined in accordance with Article 4.3.2.3.”.</p>
4.3.2.2.	<p>Replace Sentence (1) by the following:</p> <p><b>“1) The lighting power density</b> for a space, <math>LPD_{i,proposed}</math>, in W/m<sup>2</sup>, shall be calculated using the following equation:</p> $LPD_{i,proposed} = \frac{P_i}{S_i}$ <p>where</p> <p><math>P_i</math> = lighting power in space i, in W, and</p> <p><math>S_i</math> = <i>floor surface area</i> of that space, in m<sup>2</sup>.”.</p>
4.3.2.3.	<p>Replace the Article by the following:</p> <p><b>“4.3.2.3. Determination of Operational Times</b></p> <p>1) The annual operational time of each space, <math>t_i</math>, in h/a, shall be determined from the anticipated operating schedules, by taking into consideration holidays and scheduled shut-off or shut-off attributable to <i>occupant sensors</i>.</p> <p>2) Where part of a daylighted space is equipped with at least one photocontrol, the reduction of the annual operational time provided for in Sentence (1) is permitted in that part of the space</p>

	<p>a) from the detailed hourly calculations of daylight and the dynamic response of photocontrols resulting from a digital simulation conducted using specialized tools, or</p> <p>b) by applying the following reduction factors:</p> <ul style="list-style-type: none"> <li>i) 10% for photocontrols with two control levels,</li> <li>ii) 20% for multi-level photocontrols, or</li> <li>iii) 30% for continuous dimming photocontrols.</li> </ul> <p>(See Note A-4.3.2.3.(2)).”</p>
<b>4.3.2.4.</b>	Strike out the Article.
<b>4.3.2.5.</b>	Strike out the Article.
<b>4.3.2.6.</b>	Strike out the Article.
<b>4.3.2.7.</b>	Strike out the Article.
<b>4.3.2.8.</b>	Strike out the Article.
<b>4.3.2.9.</b>	Strike out the Article.
<b>4.3.2.10.</b>	Strike out the Article.
<b>4.3.3.1.</b>	<p>Replace Sentences (1) and (2) by the following:</p> <p>“<b>1)</b> The <i>interior lighting</i> energy allowance, ILEA, in kW·h/a, which is the maximum allowed <i>annual energy consumption</i> of all <i>interior lighting</i> complying with the prescriptive lighting power density determined using the space-by-space method in</p>

	<p>Article 4.2.1.6. and with the prescriptive lighting controls in Subsection 4.2.2., shall be calculated using the following equation:</p> $ILEA = \sum_{i=1}^N E_{i,reference}$ <p>where</p> <p><math>N</math> = total number of spaces in the proposed <i>building</i>, and</p> <p><math>E_{i,reference}</math> = <i>annual energy consumption</i> for lighting in space <math>i</math>, in kW×h/a, calculated in accordance with Sentence (2).</p> <p>2) The <i>annual energy consumption</i> for lighting in a space, <math>E_{i,reference}</math>, in kW×h/a, shall be calculated using the following equation:</p> $E_{i,reference} = LPD_{i,reference} \times S_i \times t_i / 1000$ <p>where</p> <p><math>LPD_{i,reference}</math> = reference LPD of space <math>i</math>, in W/m<sup>2</sup>, determined in accordance with Article 4.2.1.6.,</p> <p><math>S_i</math> = <i>floor surface area</i> of space <math>i</math>, in m<sup>2</sup>, and</p> <p><math>t_i</math> = annual operational time in space <math>i</math>, in h/a, determined in accordance with Article 4.3.2.3.”.</p>
4.3.3.2.	Strike out the Article.
4.3.3.3.	Strike out the Article.
4.3.3.4.	Strike out the Article.
4.3.3.5.	Strike out the Article.
4.3.3.6.	Strike out the Article.
4.3.3.7.	Strike out the Article.
4.3.3.10.	Strike out the Article.

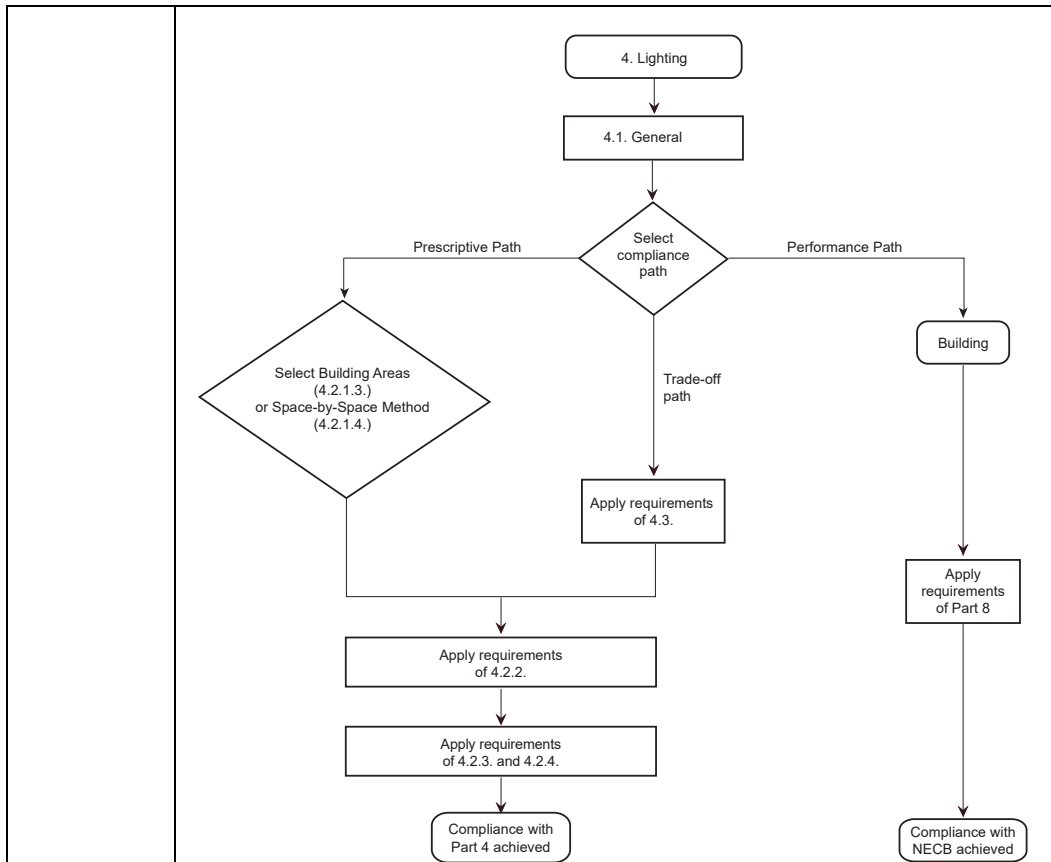
	<p>Add the following Article:</p> <p><b>“4.4.1.2. Limitations</b></p> <p>1) The <i>exterior lighting</i> and the <i>exterior lighting</i> controls shall comply with Subsections 4.2.3. and 4.2.4.</p> <p>2) The <i>interior lighting</i> controls shall comply with Subsection 4.2.2.”.</p> <hr/> <p>Replace the heading of the appropriate Article in Table 4.5.1.1. by the following:</p> <p><b>“4.3.2.3. Determination of Operational Times”;</b></p>
4.5.1.1.	<p>Replace respectively, in Table 4.5.1.1, in numerical order, the headings, the functional statements and objectives of the following Articles by the following:</p> <p><b>“4.2.2.1. Interior Lighting Controls</b></p> <p>(1) [F94-OE1.1]</p> <p>(2) [F94-OE1.1]</p> <p>(3) [F94-OE1.1]</p> <p>(4) [F94-OE1.1]</p> <p>(6) [F94-OE1.1]</p> <p>(8) [F94-OE1.1]</p> <p>(9) [F94-OE1.1]</p> <p>(10) [F94-OE1.1]</p> <p>(12) [F94-OE1.1]</p> <p>(14) [F94-OE1.1]</p> <p>(15) [F94-OE1.1]</p> <p>(16) [F94-OE1.1]”;</p> <p><b>“4.2.4.1. Requirements</b></p> <p>(1) [F94-OE1.1]</p> <p>(2) [F94-OE1.1]</p> <p>(3) [F94-OE1.1]</p> <p>(4) [F94-OE1.1]”;</p> <p><b>“4.3.1.3. Compliance</b></p> <p>(1) [F94-OE1.1]”;</p> <hr/> <p>Strike out the following objectives and functional statements in Table 4.5.1.1.:</p> <p><b>“4.2.1.3. Limits to Installed Interior Lighting Power</b></p> <p>(1) [F94-OE1.1]”;</p> <p><b>“4.2.1.5. Calculation of Interior Lighting Power Allowance Using the Building Area Method</b></p>

	<p>(2) [F94-OE1.1]  (3) [F94-OE1.1]  (4) [F94-OE1.1]  (5) [F94-OE1.1]”;</p> <p><b>“4.2.2.2. Lighting Controls in Storage Garages</b>  (4) [F94-OE1.1]”;</p> <p><b>“4.2.3.1. Exterior Lighting</b>  (2) [F94-OE1.1]”;</p> <hr/> <p>Strike out the following Articles, functional statements and objectives in Table 4.5.1.1.:</p> <p><b>“4.2.2.3. Determination of Primary and Secondary Sidelighted Areas</b>  (1) [F94-OE1.1]  (2) [F94-OE1.1]  (3) [F94-OE1.1]  (4) [F94-OE1.1]  (5) [F94-OE1.1]  (6) [F94-OE1.1]  (7) [F94-OE1.1]  (8) [F94-OE1.1]  (9) [F94-OE1.1]”;</p> <p><b>“4.2.2.4. Determination of Daylighted Area Under Roof Monitors</b>  (1) [F94-OE1.1]  (2) [F94-OE1.1]”;</p> <p><b>“4.2.2.5. Determination of Daylighted Area Under Skylights</b>  (1) [F94-OE1.1]  (2) [F94-OE1.1]”;</p> <p><b>“4.3.2.4. Determination of Non-Daylighted Area</b>  (1) [F94-OE1.1]”;</p> <p><b>“4.3.2.5. Determination of Effective Annual Operational Times</b>  (1) [F94-OE1.1]  (2) [F94-OE1.1]  (3) [F94-OE1.1]”;</p> <p><b>“4.3.2.6. Determination of Operational Times</b>  (1) [F94-OE1.1]  (2) [F94-OE1.1]”;</p>
--	--

	<p><b>“4.3.2.7. Determination of Factor for Daylight Harvesting</b></p> <p>(1) [F94-OE1.1] (4) [F94-OE1.1] (5) [F94-OE1.1]”;</p> <p><b>“4.3.2.8. Determination of the Daylight Supply Factor for Sidelighting</b></p> <p>(1) [F94-OE1.1] (2) [F94-OE1.1] (3) [F94-OE1.1] (4) [F94-OE1.1]”;</p> <p><b>“4.3.2.9. Determination of the Daylight Supply Factor for Toplighting</b></p> <p>(1) [F94-OE1.1] (2) [F94-OE1.1] (3) [F94-OE1.1]”;</p> <p><b>“4.3.2.10. Determination of Factors for Occupancy Control and Personal Control</b></p> <p>(1) [F94-OE1.1] (2) [F94-OE1.1] (3) [F94-OE1.1]”;</p> <p><b>“4.3.3.2. Determination of Lighting Power Density</b></p> <p>(1) [F94-OE1.1]”;</p> <p><b>“4.3.3.3. Determination of Daylighted Area</b></p> <p>(1) [F94-OE1.1]”;</p> <p><b>“4.3.3.4. Determination of Non-Daylighted Area</b></p> <p>(1) [F94-OE1.1]”;</p> <p><b>“4.3.3.5. Determination of Effective Annual Operational Times</b></p> <p>(1) [F94-OE1.1] (2) [F94-OE1.1] (3) [F94-OE1.1]”;</p> <p><b>“4.3.3.7. Determination of Factor for Daylight Harvesting</b></p> <p>(1) [F94-OE1.1] (4) [F94-OE1.1] (5) [F94-OE1.1]”;</p> <p><b>“4.3.3.10. Determination of Factors for Occupancy Control and Personal Control</b></p> <p>(1) [F94-OE1.1] (2) [F94-OE1.1]”.</p>
--	--

<b>Division B</b> <b>Part 4</b> <b>Schedule A</b>	
	<p>Add the following Note:</p> <p><b>“A-4.1.1.2.(2)(b) Application to Dwelling Units.</b> The interior lighting of dwelling units need not comply with the requirement of Part 4. The interior lighting of common parts of a building with dwelling units is not covered by the exclusion of that Clause and shall comply with the requirements of Part 4.”.</p>
<b>A-</b> <b>4.1.1.2.(2)(c)</b>	<p>Strike out the Note.</p>
<b>A-4.1.1.3.(1)</b>	<p>Replace the Note by the following:</p> <p><b>“A-4.1.1.3.(1) Compliance.</b> The flow chart in Figure A-4.1.1.3.(1) illustrates the process for all three paths of compliance applicable to Part 4.</p>





**Figure A-4.1.1.3.(1)**  
**Code compliance paths for lighting”.**

<p><b>A-4.2.1.3.</b></p>	<p>Replace the second Sentence of the Note by the following:                  “The two methods described in Sentence 4.2.1.3.(1) may be mixed within a building under certain conditions.”.</p>
	<p>Add the following Notes:  <b>“A-4.2.1.3.(5) Power Transfer of Interior Lighting Allowance not Used Between Several Spaces in the Same Space Assemblies.</b> For a building with a single function, such as a library, the interior lighting power allowance is determined using the building area method from an LPD of 12.8 W/m<sup>2</sup> as provided in Table 4.2.1.5. In that case, the washrooms could have an installed LPD greater than 12.8 W/m<sup>2</sup>, provided that the installed interior lighting power of the library is less than 12.8 W/m<sup>2</sup>.                  Similarly, if the interior lighting power allowance of the library were determined using the space-by-space method described in Article 4.2.1.6., the washrooms could have</p>

	<p>an LPD greater than the 10.5 W/m<sup>2</sup> provided in Table 4.2.1.6., provided that the interior lighting power allowance of the library is not exceeded.</p> <p><b>A-4.2.1.3.(6) Power Transfer of Interior Lighting Allowance not Used Between Several Space Assemblies.</b> In a building with several space assemblies, the unused portion of the interior lighting power allowance may be transferred from one assembly to the other.</p> <p>For example, in a commercial building with several suites having different functions, transfer of the unused portion of the interior lighting power allowance is permitted. The transfer may only take place in the conditions described in Sentence 4.2.1.3.(6).</p> <p><b>A-4.2.1.4. Spaces to Consider to Determine Installed Interior Lighting Power.</b> The spaces to be considered to determine the installed interior lighting power are defined in the definition for interior lighting. (See Article 1.4.1.2. and Note A-1.4.1.2. of Division A.)”.</p>
A-4.2.1.4.(2)	<p>Replace “The installed interior lighting power must include the lighting load for the installation of those typical units.” in the Note by the following:</p> <p>“Where several lighting systems are controlled to ensure independently several levels of lighting, the system with the highest lighting power must be included in the calculation of the installed interior lighting power.</p> <p>For example, in a meeting room with a first system for subdued lighting for the use of a projector and a second lighting system for tables, where the controls of the two lighting systems do not allow their simultaneous illumination, Clause 4.2.1.4.(2)(b) allows to consider only the highest power between the two systems to calculate the installed lighting power.”.</p>
	<p>Add the following Note:</p> <p><b>“A-4.2.1.4.(4)(k) Commercial Demonstration Lighting.</b> That lighting designates the lighting devices and accessories that are intended to be sold to the public (e.g. in a luminaire store) and does not include accent lighting for a commercial shop window, which is covered in Clause 4.2.1.4.(4)(g).”.</p>
A-4.2.1.5.	<p>Replace “by multiplying the gross lighted area of the building” in the Note by “by multiplying the floor surface area of the space assembly”;</p> <hr/> <p>Replace “selected based on the project's building type” in the Note by “selected based on the function of the space assembly”;</p> <hr/> <p>Strike out the last Sentence of the Note.</p>
	<p>Add the following Notes:</p>

**A-4.2.1.6.(3) Adjustment Factor of Luminaires Positioned High.** The height of the luminaires,  $H_1$ , used in calculating the adjustment factor, AF, must correspond to the height of the light source. Where luminaires are not built in the ceiling, the designer must assess their heights in relation with the floor. The exchange of the unused portion of the increased interior lighting power allowance for those of the other spaces in accordance with Sentence 4.2.1.6.(8) is permitted.

**A-4.2.1.6.(4) Additional Power of Luminaires Positioned in Corridors or Transition Areas.** The LPD in Table 4.2.1.6. concerning corridors are determined for corridors 2.4 m wide or more. For widths less than 2.4 m, the reflectance of the light on the walls increases and requires that the designer increase the lighting power to maintain a sufficient lighting level.

The exchange of the unused portion of the increased power allowances for those of the other spaces in accordance with Sentence 4.2.1.6.(8) is permitted.

**A-4.2.1.6.(5) Additional Power Due to Controls.** In certain conditions, increasing the interior lighting power allowance based on the addition of the controls referred to in Table 4.2.1.6 is permitted. Those controls are in addition to those required in Subsection 4.2.2. The exchange of the unused portion of the increased power allowances for those of the other spaces in accordance with Sentence 4.2.1.6.(8) is permitted.

**A-4.2.1.6.(6) Additional Power Due to Decorative Lighting or Display Lighting for Art Work.** Although under Clause 4.2.1.4.(4)(a), lighting in museums or art galleries for the display of art work or artefacts is excluded from the calculation of installed power, the additional power due to display lighting applies to all functions that are not museums or art galleries. For example, lighting of a floor surface area occupied by the statue of an athlete at the entrance of an arena will not be excluded from the calculation of the power by Clause 4.2.1.4.(4)(a), and could be increased by 10.8 W for each  $m^2$  of floor surface area occupied by the statue.

The additional power due to decorative lighting or display lighting for art work is not permitted where the lighting concerned only contributes to the general lighting of the space. For example, where the only source of lighting in a 100  $m^2$  corridor are wall luminaires, the luminaires are not eligible for additional lighting due to decorative lighting because the wall luminaires do not have a decorative function but are only intended for the general lighting of the corridor. According to Table 4.2.1.6., the LPD allowance for that 100  $m^2$  corridor must not exceed 7.1 W/ $m^2$  and the interior lighting power allowance for wall luminaires of the corridor will therefore be 710 W.

As provided in Sentence 4.2.1.6.(8), the exchange of the unused portion of those powers against those of other spaces is not permitted.

**A-4.2.1.6.(7) Additional Power Due to Display Lighting of Items for Sale.** Areas due to display lighting of items for sale only rarely correspond to the full floor surface area of the space considered; they are only constituted of areas occupied by the display cases concerned and an immediate traffic area around the cases.

	<p>Where the lighting only contributes to the general lighting of the space, Sentence 4.2.1.6.(7) does not allow the increase of the interior lighting power allowance.</p> <p>As provided in Sentence 4.2.1.6.(8), the exchange of the unused portion of those powers for those of the other spaces is not permitted.”.</p>
<b>A-Table 4.2.1.6.</b>	<p>Replace the Note by the following:</p> <p><b>“A-Table 4.2.1.6. Building Space Types.</b></p> <p><b>Common and Building-Specific</b></p> <p>In some cases, a space can be described as both a common space type and a building-specific space type. For example, the medical supply room in a health care facility could also be a storage room. In such case, the building-specific space type “medical supply room” must be used.</p> <p><b>Warehouse</b></p> <p>In a warehouse storage area, the space used to store small hand-carried items is sometimes referred to as a “picking area.””.</p>
<b>A-4.2.2.1.(11) and (14)</b>	Strike out the Note.
	<p>Add the following Note:</p> <p><b>“A-4.2.2.2.(2) Reduction of the Power During Unoccupied Periods in a Storage Garage.</b> To ensure user safety, uniform lighting is necessary in the garage. For that reason, the power must be reduced on each lighting unit rather than by turning off one unit out of three, for example.”.</p>
<b>A-4.2.2.3.</b>	Strike out the Note.
<b>A-4.2.2.3.(1) and (5)</b>	Strike out the Note.
<b>A-4.2.2.4.</b>	Strike out the Note.
<b>A-4.2.2.4.(1) and 4.2.2.5.(1)</b>	Strike out the Note.

<b>A-4.2.2.4.(2)</b>	Strike out the Note.
<b>A-4.2.2.5.(2)</b>	Strike out the note.
<b>A-4.2.3.1.(4)</b>	<p>Replace “Lighting” in the heading of the Note by “Transferable”;</p> <hr/> <p>Replace “puissance admissible de base” in the French text of the Note by “puissance d’allocation de base”.</p>
<b>A-4.2.3.1.(5)</b>	Strike out the Note.
	<p>Add the following Note:</p> <p><b>“A-4.2.4.1.(1) Shut-off Controls of Exterior Lighting During the Day.</b> It is possible to comply with the requirement, for example, by using photocontrolled breakers or an annual detailed program ensuring the automatic turning off of exterior lighting in the presence of daylight.”.</p>
<b>A-4.3.2.3.(2)</b>	<p>Replace the Note by the following:</p> <p><b>“A-4.3.2.3.(2) Specialized Daylight Simulation Tools.</b> A specialized daylight simulation tool allows the modeling of</p> <ul style="list-style-type: none"> <li>• radiosity,</li> <li>• ray tracing,</li> <li>• hourly distribution of diffused light sources, such as the sky,</li> <li>• direct light sources, such as the sun, and</li> <li>• photocontrol operation parameters.</li> </ul> <p>Where applicable, the specialized daylight simulation tool must also model the operation of concealment devices, such as sun breakers, designed to prevent glare for occupants.</p> <p>The reduction of the operational time provided in Sentence 4.3.2.3.(2) applies to lighting controlled by photocontrols and not to all the lighting of a space.”.</p>
<b>A-4.3.2.7.(4)</b>	Strike out the Note.
<b>A-Table 4.3.2.7.-B</b>	Strike out the Note.

<b>A-Table 4.3.2.8.</b>	Strike out the Note.
<b>A-4.3.3.7.(4)</b>	Strike out the Note.
<b>Division B Part 5</b>	
<b>5.1.1.2.</b>	<p>Replace Sentence (2) by the following:</p> <p><b>“2) Unless otherwise provided in this Part and subject to Sentence (4), this Part does not apply to HVAC systems</b></p> <p>a) serving rooms in which the processes or activities call for temperatures, airflow rates or humidity levels outside the normal range required for comfort, or</p> <p>b) dedicated entirely to a process or activity calling for temperatures, airflow rates or humidity levels outside the normal range required for comfort.</p> <p>(See Note A-5.1.1.2.(2) and (4).);</p> <hr/> <p>Add the following Sentence:</p> <p><b>“4) An HVAC system serving both rooms referred to in Sentence (2) and rooms calling for conditions within the normal range required for comfort must comply with this Part. (See Note A-5.1.1.2.(2) and (4).)”</b></p>
<b>5.2.2.3.</b>	<p>Replace the Article by the following:</p> <p><b>“5.2.2.3. Duct Sealing</b></p> <p><b>1) Except as provided in Sentences (2) to (5), air-handling ducts and <i>plenums</i> forming part of a heating, ventilating or and air-conditioning system shall be sealed like a Class A duct as described in ANSI/SMACNA 006, “HVAC Duct Construction Standards – Metal and Flexible.” (See Note A-5.2.2.3.(1).)</b></p> <p><b>2) <i>Return ducts</i> located within <i>conditioned space</i> or in spaces used as return air <i>plenums</i> need not comply with Sentence (1).</b></p> <p><b>3) Sealing tape shall not be used as the primary sealant for sections of air-handling ducts and <i>plenums</i> with a static pressure of at least 250 Pa.</b></p> <p><b>4) The joints of air-handling ducts and <i>plenums</i> shall have mechanical fasteners and be assembled so that no mechanical effort is transmitted to the sealant.</b></p> <p><b>5) Sealing tape used to seal air-handling ducts and <i>plenums</i> shall comply with UL 181A, “Closure Systems for Use with Rigid Air Ducts,” or UL 181B, “Closure Systems for Use with Flexible Air Ducts and Air Connectors.”</b></p> <p><b>6) A suspended ceiling void used as return air <i>plenum</i> need not be sealed in accordance with this Article.”</b></p>

	<p>Replace the Article by the following:</p> <p><b>“5.2.2.4. Leakage Testing of Ducts</b></p> <p><b>1)</b> The following air-handling ducts and <i>plenums</i> shall be tested for leakage in conformance with ANSI/SMACNA 016, “HVAC Air Duct Leakage Test Manual,” and comply with the maximum permitted leakage calculated in accordance with Sentence (2):</p> <p>a) air-handling ducts and <i>plenums</i> designed to operate at a static pressure of more than 750 Pa, and</p> <p>b) air-handling ducts and <i>plenums</i> located outside of the <i>building envelope</i>.</p> <p><b>2)</b> The maximum permitted leakage of air-handling ducts and <i>plenums</i> tested as described in Sentence (1) shall be calculated as follows:</p> $L_{\max} = C_L \times \left(\frac{P}{249}\right)^{0.65}$ <p>where</p> <p><math>L_{\max}</math> = maximum permitted leakage, in L/s per m<sup>2</sup> of duct surface area or <i>plenum</i>,</p> <p><math>C_L</math> = leakage class taken from Table 5.2.2.4., in L/s per m<sup>2</sup>, and</p> <p>P = maximum operating static pressure, in Pa.</p> <p style="text-align: center;"><b>Table 5.2.2.4.</b> <b>Leakage Classes (<math>C_L</math>)</b> Forming Part of Sentence 5.2.2.4.(2)</p> <table border="1" data-bbox="423 892 1255 1121"> <thead> <tr> <th rowspan="2">Shape of Air-handling Ducts and <i>Plenums</i></th> <th colspan="2">Maximum Operating Static Pressure, Pa</th> </tr> <tr> <th>750 to 1000</th> <th>&gt; 1000</th> </tr> <tr> <th></th> <th colspan="2"><math>C_L</math>, in L/s per m<sup>2</sup></th> </tr> </thead> <tbody> <tr> <td>Rectangular</td> <td>0.41</td> <td>0.20</td> </tr> <tr> <td>Round</td> <td>0.20</td> <td>0.10</td> </tr> </tbody> </table> <p><b>3)</b> The tests described in Sentence (1) shall</p> <p>a) include the sections where leakage is predominant, such as sections with elbows, and</p> <p>b) be performed over a minimum of 25% of the total surface area of the ducts and <i>plenums</i> referred to in Sentence (1).”.</p>	Shape of Air-handling Ducts and <i>Plenums</i>	Maximum Operating Static Pressure, Pa		750 to 1000	> 1000		$C_L$ , in L/s per m <sup>2</sup>		Rectangular	0.41	0.20	Round	0.20	0.10
Shape of Air-handling Ducts and <i>Plenums</i>	Maximum Operating Static Pressure, Pa														
	750 to 1000	> 1000													
	$C_L$ , in L/s per m <sup>2</sup>														
Rectangular	0.41	0.20													
Round	0.20	0.10													
<p><b>5.2.2.5.</b></p>	<p>Replace Sentence (1) by the following:</p> <p><b>“1)</b> Except as provided in Sentence (3), all air-handling ducts and <i>plenums</i> forming part of an HVAC system shall be thermally insulated in accordance with Table 5.2.2.5.”;</p> <hr/>														

Replace Table 5.2.2.5. by the following:

**“Table 5.2.2.5.  
Insulation of Ducts and Plenums**  
Forming Part of Sentences 5.2.2.5. (1) and (2) and 5.2.4.2. (3)

Temperature Difference, <sup>(1)</sup> °C	Minimum Thermal Resistance of Insulation of Ducts not Exceeding 3 m in Length that Connect to Terminal Grilles or Diffusers, m <sup>2</sup> ×°C/W	Minimum Thermal Resistance of Insulation of <i>Plenums</i> and Other Ducts, m <sup>2</sup> ×°C/W
< 5	0	0
5 to < 22	0.74	0.74
22 to < 29	0.74	1.06
29 to < 43	0.74	1.41
≥ 43	1.41	2.11

**Notes to Table 5.2.2.5.:**

- (1) Refers to the temperature difference at design conditions between the space within which the duct or *plenum* is located and the design temperature of the air carried by the same duct or *plenum*. Where the duct or *plenum* is located outside the *building envelope*,
- if used for heating purposes, the temperature difference shall be calculated using the 2.5% January design temperature of Table C-1, or
  - if used for cooling purposes, the temperature difference shall be calculated using the 2.5% July design dry-bulb temperature of Table C-1.

Where a duct or *plenum* is used for both heating and cooling purposes, the larger temperature difference shall be used.”;

Replace Sentences (3) to (9) by the following:

“**3)** The following air-handling ducts and *plenums* need not comply with the requirements of Sentence (1):

- a) *exhaust ducts*, *return ducts* and air *supply ducts* located within *conditioned space*, except as provided in Sentence 5.2.4.2.(3),
- b) ducts and *plenums* located within *conditioned space* in a *dwelling unit* and serving only that *dwelling unit*,
- c) air *supply ducts* located within return *plenums*, and
- d) provided they are insulated with a material having thermal resistance of at least 0.74 m<sup>2</sup>×°C/W:
  - i) *exhaust ducts* crossing an unconditioned space,
  - ii) *exhaust ducts* separated from *conditioned space* by an insulated *building assembly* in accordance with Subsection 3.2., and
  - iii) ducts in which outdoor air not heated and not mixed to indoor air circulates, where they cross *conditioned space*.”.

**5.2.2.7.**

Replace the Article by the following:

**“5.2.2.7. Cooling with Outdoor Air**



	<p><b>1)</b> Except as provided in Sentence (2), HVAC systems that incorporate mechanical cooling shall be designed with at least one economizer system to use outdoor air to reduce mechanical cooling energy by one of the means covered in Articles 5.2.2.8. and 5.2.2.9.</p> <p><b>2)</b> An HVAC system need not comply with the requirements of Sentence (1) where</p> <ul style="list-style-type: none"> <li>a) it has a total cooling capacity less than 16 kW,</li> <li>b) it serves only server rooms and has a total cooling capacity less than 40 kW,</li> <li>c) it serves only a <i>dwelling unit</i> or a hotel or motel <i>suite</i>,</li> <li>d) it has a non-particle filtration system (see Note A-5.2.2.7.(2)(d)),</li> <li>e) it serves a hospital, provided that more than 75% of the distributed air is humidified at a wet-bulb temperature greater than 2°C,</li> <li>f) it recovers heat on the mechanical cooling equipment (see Note A-5.2.2.7.(2)(f)),</li> <li>g) it serves spaces maintained at a temperature of at least 26°C during operating hours (see Note A-5.2.2.7.(2)(g)),</li> <li>h) it is intended to operate or work according to operating hours of less than 20 h per week, or</li> <li>i) it distributes air using at least 80% of outdoor air.</li> </ul> <p><b>3)</b> The economizer system shall be integrated to a mechanical cooling system so that</p> <ul style="list-style-type: none"> <li>a) the mechanical cooling be inactive when the economizer system can ensure alone all the cooling charge, and</li> <li>b) the mechanical cooling is partially activated when the economizer system cannot ensure alone all the cooling charge.</li> </ul> <p>(See Note A-5.2.2.7.(3).)</p> <p><b>4)</b> An HVAC system must at least use a water economizer system in accordance with Article 5.2.2.9 when the HVAC system includes</p> <ul style="list-style-type: none"> <li>a) a water loop mechanical cooling, and</li> <li>b) a humidification system that maintains indoor humidity at a wet-bulb temperature greater than 2°C.</li> </ul> <p>(See Note A-5.2.2.7.(4).)”.</p>
<p><b>5.2.2.8.</b></p>	<p>Replace Sentences (2) to (6) by the following:</p> <p><b>“2)</b> The systems described in Sentence (1) shall</p> <ul style="list-style-type: none"> <li>a) be designed to automatically revert to the minimum outdoor airflow required for acceptable indoor air quality as prescribed by the NBC when the use of outdoor air no longer allows the reduction of the cooling energy according to the conditions described in Table 5.2.2.8-A,</li> <li>b) be controlled by only one of the types of controls provided for in Table 5.2.2.8.-A, and</li> </ul>

- c) stop the direct use of outdoor air for cooling when any of the conditions resulting in the shut-off provided for in Table 5.2.2.8.-A is met.

(See Note A-5.2.2.8.(2).)

**Table 5.2.2.8.-A**  
**Type of Control and High-Limit Shut-off Control of Direct Use of Outdoor Air**  
 Forming Part of Sentence 5.2.2.8.(2)

Type of Setting	Conditions Resulting in Shut-off	
	Parameters <sup>(1)</sup>	Description
Fixed dry bulb	$T_{OA} > 21^{\circ}\text{C}$ when HDD under $18^{\circ}\text{C} < 6000$	Outdoor air temperature exceeds $21^{\circ}\text{C}$ in a locality where the number of degree-days under $18^{\circ}\text{C}$ is under 6000
	$T_{OA} > 24^{\circ}\text{C}$ when HDD under $18^{\circ}\text{C} \geq 6000$	Outdoor air temperature exceeds $24^{\circ}\text{C}$ in a locality where the number of degree-days under $18^{\circ}\text{C}$ is at least 6000
Differential dry bulb	$T_{OA} > T_{RA}$	Outdoor air temperature exceeds return air temperature
Fixed enthalpy with fixed dry bulb	$H_{OA} > 47 \text{ kJ/kg}$ or $T_{OA} > 24^{\circ}\text{C}$	Outdoor air enthalpy exceeds 47 kJ/kg or outdoor air temperature exceeds $24^{\circ}\text{C}$
Differential enthalpy with fixed dry bulb	$H_{OA} > h_{RA}$ or $T_{OA} > 24^{\circ}\text{C}$	Outdoor air enthalpy exceeds return air enthalpy or outdoor air temperature exceeds $24^{\circ}\text{C}$

**Notes to Table 5.2.2.8.-A:**

- <sup>(1)</sup>  $T_{OA}$  = temperature outdoor air,  
 $T_{RA}$  = temperature return air,  
 $H_{OA}$  = enthalpy outdoor air,  
 $h_{RA}$  = enthalpy return air.

**3)** Except as provided in Sentence (4), an HVAC system including a *supply air handler* whose mechanical cooling is direct expansion shall have at least 2 cooling stages when the mechanical cooling

- a) is integrated to cooling by direct use of outdoor air as described in Sentence (1),  
 b) has a total cooling capacity of more than 18 kW, and  
 c) is directly controlled from the space temperature.

(See Note A-5.2.2.8.(3).)

**4)** When an HVAC system including a *supply air handler* has direct expansion mechanical cooling in compliance with Table 5.2.2.8-B, that system need not comply with Sentence (3). (See Note A-5.2.2.8.(4).)

**Table 5.2.2.8.-B**  
**Minimum Number of Direct Expansion Mechanical Cooling Stage**  
 Forming Part of Sentence 5.2.2.8.(4)

Cooling Capacity <sup>(1)</sup>	Minimum Number of Mechanical Cooling Stages	Minimum Displacement of the First Cooling Stage <sup>(1)</sup>
$\geq 18 \text{ kW}$ and $< 70 \text{ kW}$	3	$\leq 33\%$ of the total cooling capacity

	<table border="1" style="width: 100%; border-collapse: collapse;"> <tr> <td style="width: 33%; text-align: center; padding: 5px;"><math>\geq 70</math> kW</td> <td style="width: 33%; text-align: center; padding: 5px;">4</td> <td style="width: 33%; text-align: center; padding: 5px;"><math>\leq 25\%</math> of the total cooling capacity</td> </tr> </table> <p><b>Notes to Table 5.2.2.8.-B:</b></p> <p><sup>(1)</sup> The values of the cooling capacity and minimum displacement of the first cooling stage apply to a variable-speed compressor.”.</p>	$\geq 70$ kW	4	$\leq 25\%$ of the total cooling capacity
$\geq 70$ kW	4	$\leq 25\%$ of the total cooling capacity		
<b>5.2.2.9.</b>	<p>Add the following line after “<b>5.2.2.9. Cooling by Indirect Use of Outdoor Air (Water Economizer System)</b>”:</p> <p>“(See Note A-5.2.2.9.)”;</p>			
<b>5.2.3.1.</b>	<p>Replace the Article by the following:</p> <p><b>“5.2.3.1. Application</b></p> <p>(See Note A-5.2.3.1. and 5.2.6.)</p> <p><b>1)</b> This Subsection applies to all fans of HVAC systems used alone or in a combination where the total rated capacities described in Sentence (4) are at least 4 kW. (See Note A-5.2.3.1.(1), (2) and (3).)</p> <p><b>2)</b> Except as provided in Sentence (3), the total of the rated capacities and the total of the brake horsepower of the fans of HVAC systems shall only include the fans that operate at design conditions requiring the highest capacity to supply air to the <i>conditioned space</i>. (See Note A-5.2.3.1.(1), (2) and (3).)</p> <p><b>3)</b> The following fans may not be included in the total rated capacities provided for in Sentence (4) and in the total brake horsepower provided for in Sentence (5):</p> <p>a) an independent exhaust fan whose motor rated capacity is not more than 750 W,</p> <p>b) an exhaust or transfer fan that serves unconditioned spaces, and</p> <p>c) a fan that dissipates the heat of an HVAC system located outside the <i>building envelope</i>, such as a condenser or a cooling tower fan.</p> <p>(See Note A-5.2.3.1.(1), (2) and (3).)</p> <p><b>4)</b> For the purposes of this Subsection, the total of the rated capacities of the fans of HVAC systems, TRC, in W, shall be the sum of the nameplate ratings of each motor.</p> <p><b>5)</b> For the purposes of this Subsection, the total brake horsepower of the fans of HVAC systems, TBHP, in W, is the sum of the brake horsepower of each fan established</p> <p>a) according to the curves or tables provided by the fan manufacturers, or</p> <p>b) using the following equation:</p> $TBHP = 0.001 \times \sum_{i=1}^n (D_i \times PS_i / \eta_i)$ <p>where</p> <p>n = number of fans,</p> <p>D<sub>i</sub> = design flow rate of the i<sup>th</sup> fan, in L/s,</p>			

$PS_i$  = design static pressure difference between both sides of the  $i^{\text{th}}$  fan, in Pa, and

$\eta_i$  = efficiency of the  $i^{\text{th}}$  fan, expressed as a decimal fraction.

6) For the purposes of Clauses 5.2.3.2.(1)(b) and 5.2.3.3.(1)(b), the values of the static pressure adjustment,  $SPA_i$ , in Pa, are those stated in Table 5.2.3.1.

**Table 5.2.3.1.**  
**Fan Design – Static Pressure Adjustment,  $SPA_i$ , in Pa**  
Forming Part of Sentence 5.2.3.1.(6)

Description	Positive Adjustment <sup>(1)</sup>
All completely channelled <i>return ducts</i> and <i>exhaust ducts</i> of the HVAC system <sup>(2)</sup>	For a laboratory and vivarium HVAC system: + 535 Pa For other HVAC system: + 125 Pa
Pressure control damper installed in a <i>return duct</i> and/or <i>exhaust duct</i> <sup>(2)</sup>	For each damper: + 125 Pa
Filter on the <i>exhaust duct</i> , scrubber or other air treatment device on the <i>exhaust duct</i>	For each filter or device: + pressure loss value provided by the manufacturer at design conditions
Particle filter with a MERV <sup>(3)</sup> efficiency included between 9 and 15	For each filter: + (28.5×MERV) – 174 Pa
Particle filter with a MERV ≥ 16 efficiency or electrostatic filter	For each filter: + double the pressure loss value provided by the manufacturer at design conditions
Carbon air purifier or using another gas phase	For each purifier: + pressure loss value provided by the manufacturer at design conditions
Biological safety cabinet	For each cabinet: + pressure loss value provided by the manufacturer at design conditions
Heat- or energy-recovery unit, except coil heat-recovery systems	For each airflow rate of the recovery unit: + (550×recovery efficiency <sup>(4)</sup> ) – 125 Pa
Coil heat-recovery system	For each airflow rate of the recovery system: + 150 Pa
Humidifier or evaporative cooler in series with another cooling coil	For each humidifier or cooler: + pressure loss value provided by the manufacturer at design conditions
Sound absorbing section	For each section: + 38 Pa
Exhaust equipment for hoods	For each equipment: + 85 Pa
<i>Exhaust ducts</i> installed in high <i>buildings</i> for laboratory and vivarium hoods	For each 30 m section of vertical duct, except the first 25 vertical metres: + 60 Pa
Natural gas or propane heat pump or <i>supply air handler</i>	For HVAC system: + 50 Pa
Description	Negative Adjustment <sup>(1)</sup>
HVAC system without cooling equipment in the <i>supply air handler</i>	For the HVAC system: – 150 Pa
HVAC system without heating equipment in the <i>supply air handler</i>	For the HVAC system: – 75 Pa

Notes to Table 5.2.3.1.:

<sup>(1)</sup> See Note A-Table 5.2.3.1.

	<p>(2) Static pressure adjustments in the air distribution system are included in the equations provided for in Clauses 5.2.3.2.(1)(b) and 5.2.3.3.(1)(b).</p> <p>(3) MERV means "minimum efficiency reporting value;" it is a measurement scale to rate the effectiveness of air filters.</p> <p>(4) Recovery unit efficiency established according to Sentence 5.2.10.1.(5)."</p>
5.2.3.2.	<p>Replace Sentence (1) by the following:</p> <p>"<b>1)</b> Except as provided in Sentence (2), where fans produce a constant airflow rate,</p> <p>a) the total of the rated capacities provided for in Sentence 5.2.3.1.(4), TRC, in W, shall not exceed the total allowable rated capacities, TARC, in W, established using the following equation:</p> $TARC = D_a \times 1.61$ <p>where</p> <p><math>D_a</math> = air supply design flow rate, in L/s, or</p> <p>b) the total of the brake horsepower provided for in Sentence 5.2.3.1.(5), TBHP, in W, shall not exceed the total allowable brake horsepower, TABHP, in W, established using the following equation:</p> $TABHP = D_a \times 1.42 + \sum_{i=1}^n (D_i \cdot SPA_i / 650)$ <p>where</p> <p><math>D_a</math> = air supply design flow rate, in L/s,</p> <p><math>n</math> = number of equipments requiring a static pressure adjustment,</p> <p><math>D_i</math> = flow from <math>i^{\text{th}}</math> equipment requiring a static pressure adjustment, in L/s (see Sentence 5.2.3.1.(5)), and</p> <p><math>SPA_i</math> = static pressure adjustment of <math>i^{\text{th}}</math> equipment, in Pa (see Sentence 5.2.3.1.(6)).</p> <p>(See Note A-5.2.3.2.(1).)</p> <p><b>2)</b> Constant-flow fan systems used for hospitals, vivariums or laboratories and whose exhaust or return flow is controlled to maintain a specific pressure for health or safety reasons may use the limits of a variable volume fan. (See Note A-5.2.3.2.(2).)".</p>

<b>5.2.3.3.</b>	<p>Replace the Article by the following:</p> <p><b>“5.2.3.3. Variable-Air-Volume Fan Systems</b></p> <p>(See Note A-5.2.3.3.)</p> <p><b>1)</b> In the case of fans automatically varying the airflow rate based on static pressure,</p> <p>a) the total of the rated capacities provided for in Sentence 5.2.3.1.(4), TRC, in W, shall not exceed the total allowable rated capacities, TARC, in W, established using the following equation:</p> $TARC = D_a \times 2.31$ <p>where</p> <p><math>D_a</math> = air supply design flow rate, in L/s, or</p> <p>b) the total of the brake horsepower provided for in Sentence 5.2.3.1.(5), TBHP, in W, shall not exceed the total allowable brake horsepower, TABHP, in W, established using the following equation:</p> $TABHP = D_a \times 2.02 + \sum_{i=1}^n (D_i \times SPA_i / 650)$ <p>where</p> <p><math>D_a</math> = air supply design flow rate, in L/s,</p> <p><math>n</math> = number of equipments requiring a static pressure adjustment,</p> <p><math>D_i</math> = flow from <math>i^{\text{th}}</math> equipment requiring a static pressure adjustment, in L/s (see Sentence 5.2.3.1.(5)), and</p> <p><math>SPA_i</math> = static pressure adjustment of <math>i^{\text{th}}</math> equipment, in Pa (see Sentence 5.2.3.1.(6)).</p> <p><b>2)</b> In variable-air-volume HVAC systems, every supply, discharge or return fan whose rated capacity is at least 7.4 kW shall operate at not more than 30% of its power demand at design conditions where the fan provides 50% of the air design flow rate. (See Note A-5.2.3.3.(2).)</p> <p><b>3)</b> Except as provided in Sentence (4), static pressure sensors used to control a variable-air-volume supply fan shall be</p> <p>a) located so that the static pressure setpoint is not more than 300 Pa, and</p> <p>b) installed downstream from the fan,</p> <p style="padding-left: 20px;">i) in the main supply duct before any intersection, or</p> <p style="padding-left: 20px;">ii) in each intersection of a main supply duct.</p> <p>(See Note A-5.2.3.3.(3).)</p> <p><b>4)</b> The static pressure setpoint of an HVAC system supply fan shall be adjusted to the value of the <i>conditioned space</i> requiring the highest static pressure when the following conditions are met:</p> <p>a) all the <i>conditioned spaces</i> of the HVAC system are individually served by terminal zone boxes,</p> <p>b) a direct digital control system is installed on the terminal zone box of each <i>conditioned space</i>, and</p>
-----------------	--

	<p>c) each direct digital control system is centralized on the supply fan main control panel.</p> <p>(See Note A-5.2.3.3.(4).)</p> <p>5) The main control panel referred to in Clause (4)(c) shall</p> <p>a) measure the opening degree of each terminal zone box,</p> <p>b) signal terminal zone boxes that remain open the longest, and</p> <p>c) permit the manual removal of the control logic of the terminal zone boxes referred to in Clause (b) to maximize the setpoint readjustment potential.”.</p>																																		
<b>5.2.3.4.</b>	Strike out the Article.																																		
<b>5.2.4.1.</b>	<p>Replace Sentence (4) by the following:</p> <p>“4) Where the duct or opening does not exceed 0.08 m<sup>2</sup>, air intake and air exhaust dampers required by Sentence (1) are permitted to be gravity or spring-operated backflow dampers.”.</p>																																		
<b>5.2.4.2.</b>	<p>Replace Sentence (3) by the following:</p> <p>“3) Dampers required in Article 5.2.4.1. are permitted to be located inboard of the <i>building envelope</i>, provided the thermal resistance of the duct insulation between the damper and the <i>building envelope</i> is that provided in Table 5.2.2.5. according to the applicable temperature difference, without being less than 0.74 m<sup>2</sup>×K/W.”.</p>																																		
<b>5.2.5.3.</b>	<p>Replace Sentence (1) by the following:</p> <p>“1) Except as provided in Sentences (2) to (6), piping and accessories forming part of an HVAC system shall be thermally insulated in accordance with Table 5.2.5.3. (See Notes A-5.2.5.3.(1) and A-5.2.2.5.(2), 5.2.5.3.(8) and 6.2.3.1.(6).)”;</p> <hr/> <p>Replace Table 5.2.5.3. by the following:</p> <p style="text-align: center;"><b>“Table 5.2.5.3.</b> <b>Minimum Thickness of Piping Insulation, in mm</b> Forming Part of Sentences 5.2.5.3.(1), (3) to (5), and (8)</p> <table border="1"> <thead> <tr> <th rowspan="3">Type of System</th> <th rowspan="3">Design Operating Temperature Range, °C</th> <th colspan="2">Thermal Conductivity of Insulation</th> <th colspan="3">Nominal Pipe Diameter, mm (inches)</th> </tr> <tr> <th rowspan="2">Conductivity Range, W/(m×K)</th> <th rowspan="2">Mean Rating Temperature, °C</th> <th>≤ 25.4 (≤ 1)</th> <th>&gt; 25.4 and ≤ 51 (&gt; 1 and ≤ 2)</th> <th>&gt; 51 (&gt; 2)</th> </tr> <tr> <th colspan="3">Minimum Thickness of Piping Insulation, mm</th> </tr> </thead> <tbody> <tr> <td rowspan="3">Heating Systems (steam, steam condensate and hot water)</td> <td>&gt; 177</td> <td>0.046 – 0.049</td> <td>121</td> <td>114</td> <td>127</td> <td>127</td> </tr> <tr> <td>122 – 177</td> <td>0.042 – 0.045</td> <td>93</td> <td>76.2</td> <td>101.6</td> <td>114</td> </tr> <tr> <td>94 – 121</td> <td>0.039 – 0.043</td> <td>65</td> <td>63.5</td> <td>63.5</td> <td>76.2</td> </tr> </tbody> </table>	Type of System	Design Operating Temperature Range, °C	Thermal Conductivity of Insulation		Nominal Pipe Diameter, mm (inches)			Conductivity Range, W/(m×K)	Mean Rating Temperature, °C	≤ 25.4 (≤ 1)	> 25.4 and ≤ 51 (> 1 and ≤ 2)	> 51 (> 2)	Minimum Thickness of Piping Insulation, mm			Heating Systems (steam, steam condensate and hot water)	> 177	0.046 – 0.049	121	114	127	127	122 – 177	0.042 – 0.045	93	76.2	101.6	114	94 – 121	0.039 – 0.043	65	63.5	63.5	76.2
Type of System	Design Operating Temperature Range, °C			Thermal Conductivity of Insulation		Nominal Pipe Diameter, mm (inches)																													
				Conductivity Range, W/(m×K)	Mean Rating Temperature, °C	≤ 25.4 (≤ 1)	> 25.4 and ≤ 51 (> 1 and ≤ 2)	> 51 (> 2)																											
		Minimum Thickness of Piping Insulation, mm																																	
Heating Systems (steam, steam condensate and hot water)	> 177	0.046 – 0.049	121	114	127	127																													
	122 – 177	0.042 – 0.045	93	76.2	101.6	114																													
	94 – 121	0.039 – 0.043	65	63.5	63.5	76.2																													

		61 – 93	0.036 – 0.042	52	38.1	50.8	50.8
		41 – 60	0.035 – 0.040	38	25.4	38.1	38.1
	Cooling Systems (chilled water, brine and refrigerant)	4 – 16	0.030 – 0.039	24	25.4	25.4	25.4
		< 4	0.030 – 0.039	24	25.4	38.1	38.1
	<p>”.</p> <p>”</p> <hr/> <p>Replace Sentence (3) by the following:</p> <p><b>“3) Piping for HVAC systems need not comply with Table 5.2.5.3. if it</b></p> <p>a) is located within a <i>conditioned space</i> and conveys fluids with design operating temperatures greater than 16°C and less than 41°C,</p> <p>b) is used only to reject heat and is located outside the <i>building envelope</i>, or</p> <p>c) is used for the circulation of a fluid that is neither heated nor cooled by electricity or a fossil fuel. (See Note A-5.2.5.3.(3)c).”;</p> <hr/> <p>Strike out “(See Note A-5.2.2.5.(8) and 5.2.5.3.(7).)” in Sentence (7).</p>						
<b>5.2.6.</b>	<p>Replace the heading by the following:</p> <p><b>“5.2.6. Pumping System Design</b></p> <p>(See Note A-5.2.3.1. and 5.2.6.)”.</p>						
<b>5.2.6.1.</b>	<p>Replace Sentences (1) and (2) by the following:</p> <p><b>“1) This Subsection applies to pumping of HVAC systems</b></p> <p>a) with a total of the pump system motor power ratings in Sentence (2) of at least 7.5 kW, and</p> <p>b) including control valves designed to modulate or to open and close in steps as a function of thermal energy load.</p> <p><b>2) For the purposes of this Subsection, the total of the pump motor power ratings of the HVAC system shall be the sum of the nameplate power ratings of each pump motor required to operate at design conditions to supply thermal energy to an HVAC system or <i>conditioned space</i>.”.</b></p>						
<b>5.2.6.2.</b>	<p>Replace the Article by the following:</p> <p><b>“5.2.6.2. Requirements for Pumping Systems of HVAC Systems</b></p> <p><b>1) Except as provided in Sentence (2), pumping systems that provide thermal energy to an HVAC system or a <i>conditioned space</i> shall be</b></p> <p>a) designed for variable fluid flow, and</p> <p>b) capable of reducing system flow to 50% or less of design flow.</p>						



	<p>(See Note A-5.2.6.2.(1).)</p> <p><b>2)</b> Sentence (1) does not apply to pumping systems that provide thermal energy to an HVAC system or a <i>conditioned space</i></p> <p>a) in which a minimum flow greater than 50% of the design flow is required for the proper operation of the HVAC system,</p> <p>b) with a single control valve, or</p> <p>c) that include controls to reset the fluid supply temperature based on either outdoor temperature or HVAC system loads.”.</p>
<b>5.2.6.3.</b>	Strike out the Article.
<b>5.2.8.1.</b>	<p>Replace “include at least one automatic space temperature control device that is accurate to within 1°C” in Sentence (1) by “serve at least one <i>temperature-control zone</i>”;</p> <hr/> <p>Strike out Sentence (2).</p>
<b>5.2.8.2.</b>	<p>Replace Sentence (1) by the following:</p> <p>“<b>1)</b> Each <i>dwelling unit</i> shall be considered as at least one <i>temperature-control zone</i>.”;</p> <hr/> <p>Strike out Sentence (2).</p>
<b>5.2.8.4.</b>	<p>Replace Clause (1)(b) by the following:</p> <p>“b) on interior walls, or on exterior walls with an <i>effective thermal resistance</i> of at least 3.60 (m<sup>2</sup>×K)/W”.</p>
<b>5.2.8.5.</b>	Strike out “(See Note A-5.2.8.5.(1) and 5.2.11.1.(2)(e).)” in Sentence (1).
<b>5.2.8.6.</b>	<p>Replace “to a zone” in Sentence (1) by “to a <i>temperature-control zone</i>”;</p> <hr/> <p>Replace “the zone(s) it serves” in Clause (2)(b) by “the <i>temperature-control zone(s)</i> it serves”;</p> <hr/> <p>Replace “a space” in Sentence (3) by “a <i>temperature-control zone</i>”;</p> <hr/> <p>Replace Sentences (4) and (5) by the following:</p>

	<p>“4) Where heating and cooling to a <i>temperature-control zone</i> are controlled by the same thermostatic control, the difference between the heating cycle shutdown temperature and the cooling cycle startup temperature shall be at least 1.5°C and conversely.</p> <p>5) Vestibules between <i>conditioned spaces</i> and the outdoors shall</p> <p>a) have a temperature-control device that limits the maximum heating temperature in the vestibule to 15°C, or</p> <p>b) be heated by an air curtain equipped with shut-off settings activated when the exterior entry doors are closed.”.</p>
5.2.8.7.	<p>Replace the Article by the following:</p> <p><b>“5.2.8.7. Ice- and Snow-Melting Heater Controls and Frost Protection Equipment</b></p> <p>1) Ice- and snow-melting heating systems located outside the <i>building</i> shall be provided with automatic controls that shut the systems down where</p> <p>a) the outdoor temperature is more than 4.4°C, or</p> <p>b) the temperature of the surface with a heating system is more than 10°C.</p> <p>2) Equipment for protecting piping located outside the <i>building</i> against frost using a heating cable shall be equipped with automatic controls that shut down the equipment</p> <p>a) where the outdoor temperature is more than 4.4°C, or</p> <p>b) where there is no risk of frost for the fluid circulating in the protected piping.”.</p>
5.2.8.8.	<p>Replace Sentence (2) by the following:</p> <p>“2) Reheating supply air previously cooled to reach the required humidity level is permitted. (See Note A-5.2.8.8.(2).)”;</p> <hr/> <p>Insert “(See Note A-5.2.8.8.(3).)” at the end of Sentence (3).</p>
5.2.8.9.	<p>Replace the term “Except as provided in Sentence (4)” wherever it appears in Sentences (1) to (3) by “Except as provided in Sentence (6)”;</p> <hr/> <p>Replace Sentence (4) by the following:</p> <p>“4) Except as provided in Sentence (6), the airflow rate that is reheated, cooled or mixed in the <i>temperature-control zones</i> without a direct digital control system shall not exceed the highest flow among the following:</p> <p>a) 30% of the maximum supply flow in the <i>temperature-control zone</i>, or</p> <p>b) the outdoor airflow rate required for acceptable indoor air quality as prescribed by the NBC.</p>

	<p>(See Note A-5.2.8.9.(4) and (5).)</p> <p><b>5)</b> Except as provided in Sentence (6), <i>temperature-control zones</i> with a direct digital control system shall have</p> <p>a) a supply airflow rate not exceeding the highest flow from among the following, where the supply airflow rate of the <i>temperature-control zone</i> is neither heated nor cooled:</p> <p>i) 20% of the maximum supply flow of the <i>temperature-control zone</i>, or</p> <p>ii) the outdoor airflow required for acceptable indoor air quality as prescribed by the NBC,</p> <p>b) an airflow reheated, cooled or mixed less than 50% of the maximum supply flow of the <i>temperature-control zone</i>, and</p> <p>c) the following heating sequence:</p> <p>i) a first heating stage to modulate the zone temperature setpoint to the maximum supply temperature and to maintain an airflow rate equal to that established in Clause (5)(a), and</p> <p>ii) a second heating stage to maintain the zone temperature setpoint to its maximum value and to modulate the airflow rate to the airflow rate provided for in Clause (5)(b).</p> <p>(See Note A-5.2.8.9.(4) and (5).)</p> <p><b>6)</b> Sentences (1) to (5) do not apply in <i>temperature-control zones</i> in which at least 75% of the energy necessary for heating shall be provided by</p> <p>a) the energy recovered at the site, or</p> <p>b) the solar energy produced at the site, except the energy due to passive heat gain created by <i>fenestration</i>.</p> <p>(See Note A-5.2.8.9.(6).)”.</p>
<b>5.2.9.</b>	<p>Replace the heading of the Subsection by the following:</p> <p><b>“5.2.9. Humidification and Dehumidification”.</b></p>
<b>5.2.10.1.</b>	<p>Replace Sentence (1) by the following:</p> <p><b>“1)</b> Except as provided in Sentence (3), when the quantity of sensible heat of the exhaust air equipment as calculated in accordance with Sentence (4) exceeds 50 kW, the HVAC system shall be equipped with energy recovery equipment compliant with Sentence (5). (See Note A-5.2.10.1.(1).)”;</p> <hr/> <p>Replace Sentences (3) to (5) by the following:</p> <p><b>“3)</b> The following equipment need not comply with Sentence (1):</p> <p>a) specialized exhaust equipment, such as those used to exhaust smoke, grease-laden vapours, or toxic, flammable, paint, or corrosive fumes or dust,</p> <p>b) exhaust equipment operated less than 20 h per week, and</p>

	<p>c) exhaust equipment serving <i>conditioned spaces</i> with a temperature maintained at less than 16°C.</p> <p><b>4)</b> The sensible heat, in kW, referred to in Sentence (1), which is the sensible heat content of the total quantity of exhaust, shall be calculated as follows:</p> $\text{Sensible heat} = 0.00123 \times Q \times (T_e - T_o)$ <p>where</p> <p>Q = rated capacity of the exhaust system at normal exhaust air temperature, in L/s,</p> <p>T<sub>e</sub> = temperature of exhaust air before heat recovery, in °C, and</p> <p>T<sub>o</sub> = outdoor 2.5% January design temperature, in °C.</p> <p><b>5)</b> Heat- or energy-recovery equipment shall have</p> <p>a) a net sensible efficiency of at least 60% where the efficiency is</p> <ol style="list-style-type: none"> <li>i) established at 100% of the heating test flow,</li> <li>ii) measured according to ANSI/AHRI 1061 (SI), "Performance Rating of Air-to-Air Exchangers for Energy Recovery Ventilation Equipment," and</li> <li>iii) certified by AHRI, by Intertek Testing Services NA Ltd. or by Element Materials Technology Canada Inc., or</li> </ol> <p>b) a sensible heat-recovery capacity of at least 55% where the recovery capacity is</p> <ol style="list-style-type: none"> <li>i) established at a flow of at least 22 L/s for a temperature at the supply air inlet of -25°C,</li> <li>ii) measured according to CAN/CSA-C439, "Standard Laboratory Methods of Test for Rating the Performance of Heat/Energy-Recovery Ventilators," and</li> <li>iii) certified by HVI or other certification body that is accredited by the Standards Council of Canada." </li></ol>
<p><b>5.2.10.2.</b></p>	<p>Replace the Article by the following:</p> <p><b>"5.2.10.2. Swimming Pools</b></p> <p><b>1)</b> HVAC systems for swimming pools with a surface area of at least 10 m<sup>2</sup> located within <i>conditioned spaces</i> shall comply with Sentences (2) and (3).</p> <p><b>2)</b> Exhaust air equipment of the swimming pool referred to in Sentence (1) shall</p> <ol style="list-style-type: none"> <li>a) have an exhaust airflow limited to the outdoor airflow required for acceptable indoor air quality as prescribed by the NBC, and</li> <li>b) recover at least 60% of the sensible heat of the exhaust air at the design conditions in compliance with Sentence 5.2.10.1.(5).</li> </ol> <p>(See Note A-5.2.10.2.(2).)</p>

	<p><b>3)</b> HVAC systems that serve a swimming pool referred to in Sentence (1) shall include mechanical dehumidification equipment that</p> <p>a) ensures untreated dehumidification by the exhaust air equipment described in Sentence (2), and</p> <p>b) rejects heat from dehumidification in <i>building</i> systems. (See Note A-5.2.10.2.(3)(b).)”.</p>
5.2.10.3.	<p>Replace the Article by the following:</p> <p><b>“5.2.10.3. Refrigeration Systems</b></p> <p><b>1)</b> The following systems shall comply with Sentences (2) and (3):</p> <p>a) refrigeration systems for creating or maintaining an ice sheet in heated <i>buildings</i>, such as an ice arena or a curling rink, and</p> <p>b) refrigeration systems</p> <p>i) for food conservation,</p> <p>ii) installed in heated <i>buildings</i> with a <i>building</i> area of more than 2500 m<sup>2</sup>, and</p> <p>iii) composed of several equipment connected to a centralized refrigeration system. (See Note A-5.2.10.3.(1)(b).)</p> <p><b>2)</b> The refrigeration systems referred to in Sentence (1) shall include heat-recovery equipment</p> <p>a) that recovers at least 25% of the heat before it is rejected to the condenser (see Note A-5.2.10.3.(2)(a)), or</p> <p>b) that meets at least 80% of the space heating or <i>service water</i> heating capacity. (See Note A-5.2.10.3.(2)(b).)</p> <p><b>3)</b> The heat-recovery equipment described in Sentence (2) shall not increase the refrigerant saturation temperature beyond the temperature established at design conditions.</p> <p><b>4)</b> Auxiliary heating in a space heated by the heat-recovery equipment described in Sentence (2) is not permitted to operate where the equipment may completely ensure the heating load of that space.”.</p>
5.2.10.4.	<p>Replace the Article by the following:</p> <p><b>“5.2.10.4. Dwelling units</b></p> <p><b>1)</b> The principal mechanical ventilation system of a <i>dwelling unit</i> shall be equipped with heat- or energy-recovery equipment. (See Note A-5.2.10.4.(1).)</p> <p><b>2)</b> The heat- or energy-recovery equipment referred to in Sentence (1) shall have</p> <p>a) for equipment serving only one <i>dwelling unit</i>, a sensible heat-recovery capacity of at least 55% in the case of a <i>building</i> located in a municipality whose number of degree-days under 18°C is less than 6000 and of at least 60% in the case of a <i>building</i> located in another municipality where the recovery capacity is</p> <p>i) established at a flow of at least 22 L/s for a supply air inlet temperature of -25°C,</p>

	<ul style="list-style-type: none"> <li>ii) measured according to CAN/CSA-C439, “Standard Laboratory Methods of Test for Rating the Performance of Heat/Energy-Recovery Ventilators,” and</li> <li>iii) certified by HVI or by other certification body that is accredited by the Standards Council of Canada (see Note A-5.2.10.4.(2)(a)), or</li> </ul> <p>b) in other cases, net sensible efficiency of at least 60% in the case of a <i>building</i> located in a municipality whose number of degree-days under 18°C is less than 6000 and of at least 65% in the case of a <i>building</i> located in another municipality where the efficiency is</p> <ul style="list-style-type: none"> <li>i) established at 100% of the heating test flow,</li> <li>ii) measured according to ANSI/AHRI 1061 (SI), “Performance Rating of Air-to-Air Exchangers for Energy Recovery Ventilation Equipment,” and</li> <li>iii) certified by AHRI, by Intertek Testing Services NA Ltd. or by Element Materials Technology Canada Inc.”.</li> </ul>
5.2.11.1.	<p>Replace Sentence (1) by the following:</p> <p>“1) The following HVAC systems shall be equipped with automatic controls complying with Sentences (2) and (4):</p> <ul style="list-style-type: none"> <li>a) HVAC systems that are not intended to operate continuously,</li> <li>b) HVAC systems serving <i>dwelling units</i>,</li> <li>c) HVAC systems whose heating or cooling capacity is more than 5 kW, or</li> <li>d) HVAC systems <ul style="list-style-type: none"> <li>i) whose heating or cooling capacity is 5 kW or less, and</li> <li>ii) serving <i>temperature-control zones</i> that are not equipped with readily accessible manual controls.</li> </ul> </li> </ul> <p>(See Note A-5.2.11.1.(1).)”;</p> <hr/> <p>Replace Clause (2)(e) by the following:</p> <p>“e) in the case of heat pumps, temporarily suppressing supplementary heating elements or anticipation of the reaching of the setpoint established during periods of occupancy. (See Note A-5.2.11.1.(2)(e)”;</p> <hr/> <p>Strike out Sentence (3).</p>
5.2.11.2.	<p>Replace Sentences (1) to (3) by the following:</p> <p>“1) Except as provided in Sentences (7) and (8), each air distribution system serving multiple <i>temperature-control zones</i> shall be divided into <i>airflow control areas</i>. (See Note A-5.2.11.2.(1) and (2).)</p> <p>2) Each <i>airflow control area</i> required by Sentence (1) shall serve a <i>floor surface area</i> of not more than 2300 m<sup>2</sup>. (See Note A-5.2.11.2.(1) and (2).)</p> <p>3) Each <i>airflow control area</i> required by Sentence (1) shall include only the <i>temperature-control zones</i> to be operated simultaneously.”;</p>

	<p>Replace “Sentences (1) and (2)” in Sentence (4) by “Sentence (1)”;</p> <hr/> <p>Insert “(See Note A-5.2.11.2.(5).)” at the end of Sentence (5);</p> <hr/> <p>Replace Sentences (7) and (8) by the following:</p> <p>“<b>7)</b> Controls and devices such as direct digital control and variable-air-volume systems shall be provided to allow stable operation of all associated HVAC systems for any length of time while they are serving a single <i>airflow control area</i> (see note A-5.2.11.2.(7)).</p> <p><b>8)</b> The following need not be incorporated into <i>airflow control areas</i>:</p> <p>a) <i>temperature-control zones</i> in which outdoor air and exhaust requirements prevent the reduction or stopping of the air supply, or</p> <p>b) <i>dwelling units</i>.”.</p>
5.2.11.3.	<p>Replace “HVAC pumping systems” in Sentence (1) by “HVAC systems”.</p>
5.2.11.4.	<p>Insert “(See Note A-5.2.11.4.(1).)” at the end of Sentence (1);</p> <hr/> <p>Replace Sentences (2) and (3) by the following:</p> <p>“<b>2)</b> Except as provided in Sentence (3), where the heating load of <i>boilers</i> of an HVAC system exceeds 176 kW, the HVAC system shall consist of</p> <p>a) more than one <i>boiler</i>,</p> <p>b) a multi-stage <i>boiler</i>, or</p> <p>c) a fully modulating <i>boiler</i>.</p> <p><b>3)</b> Where the heating load of the <i>boilers</i> of an HVAC system exceeds 352 kW, those <i>boilers</i> shall be fully modulating.”.</p>
5.2.11.5.	<p>Replace Sentence (1) by the following:</p> <p>“<b>1)</b> Except as provided in Sentences (2) and (3), chilled- or hot-water systems with a design capacity greater than 88 kW supplying chilled or heated water to an HVAC system shall be equipped with automatic controls that reset the supply water loop temperatures</p> <p>a) in relation to the outdoor temperature using an indoor/outdoor controller, or</p> <p>b) in relation to the <i>building</i> heating and cooling loads.</p> <p>(See Note A-5.2.11.5.(1).)”;</p> <hr/>

	Insert "(See Note A-5.2.11.5.(2).)" at the end of Sentence (2).
<b>5.2.12.1.</b>	<p>Replace Sentence (1) by the following:</p> <p><b>"1)</b> Unitary and packaged equipment and components that are part of a <i>building</i> HVAC system shall comply</p> <p>a) with the efficiency requirements provided for in the Act respecting energy efficiency and energy conservation standards for certain products (chapter N-1.01) and its regulations, as well as Federal regulations, or</p> <p>b) in the absence of the requirements described in Clause (a), with the requirements listed in Tables 5.2.12.1.-A to 5.2.12.1.-P.</p> <p>(See Notes A-5.2.12.1.(1) and A-5.2.12.1.(1), 6.2.2.1.(1), 7.2.3.1.(1) and 7.2.4.1.(1).) (See Note 6.2.2.4.)".</p>
<b>5.2.12.2.</b>	Strike out the Article.
<b>5.2.12.3.</b>	Strike out the Article.
<b>5.2.12.4.</b>	Strike out the Article.
	<p>Add the following Subsection:</p> <p><b>"5.2.13. Commercial Cooking Ventilating System"</b>.</p>
	<p>Add the following Article:</p> <p><b>"5.2.13.1. Commercial Cooking Ventilating System</b></p> <p><b>1)</b> The make-up airflow introduced directly in the commercial cooking air exhaust system shall be less than 10% of the exhaust airflow. (See Note A-5.2.13.1.(1).)</p> <p><b>2)</b> Commercial cooking exhaust air systems with a cumulative flow of more than 2360 L/s shall comply with one of the following requirements:</p> <p>a) at least 50% of the airflow rate necessary to offset the cooking exhaust rate shall come from available transfer air, in L/s, established using the following equation:</p> $\text{Available transfer air} = D_a - D_w - D_e$ <p>where</p> <p><math>D_a</math> = outdoor airflow entering the <i>building</i>, excluding the make-up outdoor airflow directly serving the kitchen, in L/s,</p> <p><math>D_w</math> = airflow extracted from washrooms, in L/s, and</p> <p><math>D_e</math> = outdoor airflow to offset other exhaust equipment, in L/s.</p>



	<p>(See Note A-5.2.13.1.(2)(a));</p> <p>b) at least 75% of the cooking exhaust rate shall come from an exhaust demand air system that shall</p> <p style="padding-left: 20px;">i) detect cooking emissions (see Note A-5.2.13.1.(2)(b)(i)), and</p> <p style="padding-left: 20px;">ii) reduce to at least 50% exhaust and make-up flows in the absence of cooking emission, or</p> <p>c) at least 40% of the sensible heat shall be recovered over at least 50% of the cooking exhaust rate by a heat-recovery unit designed for that purpose.”.</p>
5.4.1.2.	<p>Replace the Article by the following:</p> <p><b>“5.4.1.2. Limitations</b></p> <p>1) The performance path shall not take into consideration the energy performance</p> <p style="padding-left: 20px;">a) of back-up HVAC systems,</p> <p style="padding-left: 20px;">b) air distribution systems,</p> <p style="padding-left: 20px;">c) air intake and outlet dampers,</p> <p style="padding-left: 20px;">d) Piping for an HVAC system,</p> <p style="padding-left: 20px;">e) space temperature control, and</p> <p style="padding-left: 20px;">f) <i>airflow control areas</i>.</p> <p>(See Note A-5.4.1.2.(1) and 2).)</p> <p>2) The elements in Sentence (1) shall comply with Section 5.2. (See Note A-5.4.1.2.(1) and (2).)”.</p>
5.5.1.1.	<p>Replace the heading of the appropriate Article in Table 5.5.1.1. by the following:</p> <p><b>“5.2.6.2. Requirements for Pumping Systems of HVAC Systems”;</b></p> <hr/> <p>Replace respectively, in numerical order, the headings, objectives and functional statements of the Articles concerned below by the following in Table 5.5.1.1:</p> <p><b>“5.2.8.7. Ice- and Snow-Melting Heater Controls and Frost Protection Equipment</b></p> <p>(1) [F95-OE1.1]</p> <p>(2) [F95-OE1.1]”;</p> <p><b>“5.2.10.3. Refrigeration Systems</b></p> <p>(1) [F95,F96,F100-OE1.1]</p> <p>(2) [F95,F96,F100-OE1.1]</p> <p>(3) [F95,F96,F100-OE1.1]</p> <p>(4) [F95,F96,F100-OE1.1]”;</p> <hr/>

Replace the attributions for the Article concerned below by the following in Table 5.5.1.1:

**“5.2.2.3. Duct Sealing**

- (1) [F91,F99-OE1.1]
- (3) [F91,F99-OE1.1]
- (4) [F91,F99-OE1.1]
- (5) [F91,F99-OE1.1]”;

**“5.2.2.4. Leakage Testing of Ducts**

- (1) [F91,F99-OE1.1]
- (2) [F91,F99-OE1.1]
- (3) [F91,F99-OE1.1]”;

**“5.2.2.7. Outdoor Air Cooling**

- (1) [F95-OE1.1]
- (3) [F95-OE1.1]
- (4) [F95-OE1.1]”;

**“5.2.3.1. Application**

- (2) [F95,F97-OE1.1]
- (4) [F95,F97-OE1.1]
- (5) [F95,F97-OE1.1]
- (6) [F95,F97-OE1.1]”;

**“5.2.10.2. Swimming Pools**

- (1) [F95,F100-OE1.1]
- (2) [F95,F100-OE1.1]
- (3) [F95,F100-OE1.1]”;

**“5.4.1.2. Limitations**

- (1) [F98,F99-OE1.1]
- (2) [F98,F99-OE1.1]”;

---

Insert respectively, in numerical order, the following objectives and functional statements in Table 5.5.1.1.:

**“5.2.3.3. Variable-Air-Volume Fan Systems**

- (4) [F95,F97-OE1.1]
- (5) [F95,F97-OE1.1]”;

**“5.2.8.9. Control of Space Temperature by Reheating or Recooling**

- (4) [F95-OE1.1]
  - (5) [F95-OE1.1]”;
-

	<p>Insert, in numerical order, the following Article, objectives and functional statements in Table 5.5.1.1.:</p> <p><b>“5.2.13.1. Commercial Cooking Ventilating System</b></p> <p>(1) [F95-OE1.1]</p> <p>(2) [F95-OE1.1]”;</p> <hr/> <p>Strike out respectively the following objectives and functional statements in Table 5.5.1.1:</p> <p><b>“5.2.2.5. Duct and Plenum Insulation</b></p> <p>(6) [F93-OE1.1]</p> <p>(8) [F92,F93-OE1.1]</p> <p>(9) [F93,F95,F99-OE1.1]”;</p> <p><b>“5.2.2.8. Cooling by Direct Use of Outdoor Air (Air Economizer System)</b></p> <p>(5) [F95-OE1.1]”;</p> <p><b>“5.2.8.1. Temperature Controls</b></p> <p>(2) [F95-OE1.1]”;</p> <p><b>“5.2.8.2. Temperature Control within Dwelling Units</b></p> <p>(2) [F95-OE1.1]”;</p> <p><b>“5.2.10.4. Heat Recovery in Dwelling Units</b></p> <p>(3) [F95,F100-OE1.1]</p> <p>(4) [F95,F100-OE1.1]</p> <p>(5) [F95,F100-OE1.1]”;</p> <hr/> <p>Strike out the following Articles, objectives and functional statements in Table 5.5.1.1.:</p> <p><b>“5.2.3.4. Demand Control Ventilation Systems</b></p> <p>(1) [F95,F97-OE1.1]”;</p> <p>(2) [F95,F97-OE1.1]”;</p> <p><b>“5.2.6.3. Pumping Power Demand</b></p> <p>(1) [F95,F97,F98,F99-OE1.1]”;</p> <p><b>“5.2.12.2. Heat Rejection Equipment</b></p> <p>(2) [F95,F97,F98,F99-OE1.1]</p> <p>(3) [F95,F97-OE1.1]”;</p> <p><b>“5.2.12.3. Field-Assembled Equipment and Components</b></p> <p>(1) [F99-OE1.1]”;</p> <p><b>“5.2.12.4. Service Water Heating Equipment Used for Space Heating</b></p> <p>(1) [F98-OE1.1]”.</p>
--	---

<b>Division B</b> <b>Part 5</b> <b>Schedule A</b>	
<b>A-5.1.1.2.(2)</b>	Strike out the Note.
	<p>Add the following Note:</p> <p><b>“A-5.1.1.2.(2) and (4) HVAC System and Process or Activities.</b> An HVAC system fully dedicated to a process or an activity described in Sentence 5.1.1.2.(2) is exempted from complying with Part 5. The Code provides provisions to the contrary, in particular for HVAC systems serving the following rooms, processes and activities that are not exempted from Part 5 requirements:</p> <ul style="list-style-type: none"> <li>• server rooms (Article 5.2.2.7.),</li> <li>• laboratories and vivariums (Subsection 5.2.3.),</li> <li>• hospitals (Article 5.2.2.7. and Subsection 5.2.3.),</li> <li>• swimming pools (Article 5.2.10.2.),</li> <li>• ice-making machines and food refrigeration equipment (Article 5.2.10.3.), and</li> <li>• commercial cooking exhaust equipment (Subsection 5.2.13.).</li> </ul> <p>In addition, Sentence 5.1.1.2.(4) provides that an HVAC system serving both a room that requires usual comfort conditions and a room in which a process calls for temperatures, airflows or humidity rates outside the normal range required cannot benefit from the exemption permitted in Sentence 5.1.1.2.(2).</p> <p>In compliance with the performance path, process and activity HVAC systems must be modeled since they have an impact on the heating, cooling and/or humidification load of rooms adjacent to the process or activity.”.</p>
<b>A-5.1.1.3.(2)</b>	Replace “primary system” in the Note by “HVAC systems”.
<b>A-5.2.2.3.(1)</b>	<p>Replace the Note by the following:</p> <p><b>“A-5.2.2.3.(1) Duct Sealing.</b> Even if ANSI/SMACNA 006, “HVAC Duct Construction Standards – Metal and Flexible” is less restrictive for certain sealing classes, all air ducts and plenums must be sealed as a class A duct, i.e. at every transversal joints, along all the longitudinal assembly lines and where the ducts penetrate walls, as required by Sentence 5.2.2.3.(1).</p> <p>Sealing applies both to positive pressure ducts and negative pressure ducts.”.</p>

<b>A-5.2.2.3.(4)</b>	Strike out the Note.
<b>A-5.2.2.4.(1)</b>	Strike out the Note.
<b>A-5.2.2.5.(2), 5.2.5.3.(8) and 6.2.3.1.(6)</b>	Add the following at the end of the Note: "The minimum insulation thicknesses required may have to be increased to eliminate condensation on ducts or to protect against burns."
<b>A-5.2.2.5.(4)</b>	Strike out the Note.
<b>A-5.2.2.5.(8) and 5.2.5.3.(7)</b>	Strike out the Note.
	<p>Add the following Notes:</p> <p><b>A-5.2.2.7.(2)(d) Non-particle Filtration.</b> Contrary to particle filtration, non-particle filtration is generally used where the outdoor air is polluted or where the indoor air quality must be controlled, such as a medical environment where a molecular filter is used to remove ozone and nitrogen oxides. That type of air handler uses energy and the addition of an economizer system requires to design the air handler not for the minimum new air but for 100% of the supply flow. In that case, the energy gain obtained by not operating the mechanical cooling may cancel itself or even transform itself into greater energy consumption.</p> <p><b>A-5.2.2.7.(2)(f) Heat-Recovery Unit in Coolers.</b> Where the cooler has a heat-recovery unit on its condenser, shutting down of the cooler for using the economizer system would cancel the heating savings due to recovery.</p> <p><b>A-5.2.2.7.(2)(g) Semi-conditioned Spaces During Operating Hours.</b> Energy savings related to an economizer system depend mostly on the cooling needs of the spaces during heating. In most cases, a cooling setpoint of at least 26°C does not generate sufficient cooling needs to justify the cost for the installation of an economizer system.</p> <p><b>A-5.2.2.7.(3) Cooling by the Use of Outdoor Air Integrated to the Mechanical Cooling.</b> Based on the outdoor air temperature and the cooling demand, the cooling load will be ensured only by the economizer system, by a combination of the economizer system and mechanical cooling or only by mechanical cooling.</p>

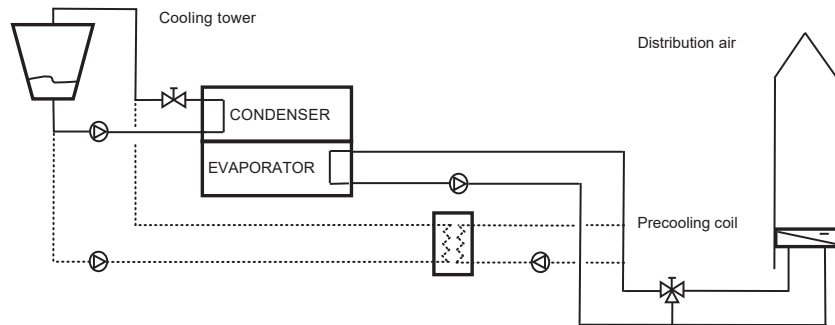
	<p><b>A-5.2.2.7.(4) Water Economizer System where the HVAC System Includes Hydronic Loop Cooling and a Humidification System.</b> The humidification systems used simultaneously with an air economizer system may consume a lot of energy because the introduction of dry air in winter adds a significant humidification load. To prevent excessive energy consumption, the economizer system, where required, must be on the water system and not on the air system. That requirement is limited to hydronic loop mechanical cooling and not to direct expansion cooling.”.</p>
<p><b>A-5.2.2.8.(2)</b></p>	<p>Replace the Note by the following:</p> <p><b>“A-5.2.2.8.(2) Outdoor Air Intake for Acceptable Indoor Air Quality.</b> Outdoor air requirements for acceptable indoor air quality are covered in Part 6 of Division B of the NBC.</p> <p><b>Types of Shut-off Settings.</b> Only the shut-off settings in Table 5.2.2.8.-A are permitted.</p> <p>Combining two types of settings or dividing one type of setting is not permitted.”.</p>
	<p>Add the following Notes:</p> <p><b>“A-5.2.2.8.(3) Minimum Mechanical Cooling Stage Controlled Directly from Room Temperature.</b> When the direct expansion mechanical cooling activates in addition to the outdoor air cooling, the objective is not to reduce the supply temperature so as to create discomfort in the conditioned zone. That means that the mechanical cooling operates at a minimum of two stages, by the use of multiple compressors, by the use of only one two-stage compressor or by the use of a variable-speed compressor.</p> <p>Sentence 5.2.2.8.(3) applies to mechanical cooling directly controlled from room temperature rather than the supply temperature of the air handler. In the latter case, the requirements of Sentence 5.2.2.8.(4) apply.</p> <p><b>A-5.2.2.8.(4) Minimum Mechanical Cooling Stage.</b> Sentence 5.2.2.8.(4) applies in particular to variable-air-volume HVAC systems controlled from the air handler supply air temperature. For example, where three mechanical cooling stages are required, the requirement may be complied with using a variable-speed compressor. In that case, the minimum displacement of the compressor must be less than or equal to 33% of the total cooling capacity.</p> <p>Another possibility is to use two compressors, the first stage uses a compressor with a 33% total cooling capacity, the second stage uses a compressor with 66% displacement and the third stage uses the combination of two compressors to reach 100% of the total cooling capacity. In that case, the cooling capacity provided by the first stage is equivalent to the minimum displacement of 33% of a variable-speed compressor.”.</p>
<p><b>A-5.2.2.8.(6)</b></p>	<p>Strike out the Note.</p>

Add the following Note:

**“A-5.2.2.9. Water Economizer System.** The water economizer system reduces the mechanical cooling load by cooling the heat transfer fluid of the cooling system with outdoor air. The energy savings are made by reducing the compressor use time. There are two typical compliant configurations for the water economizer system,

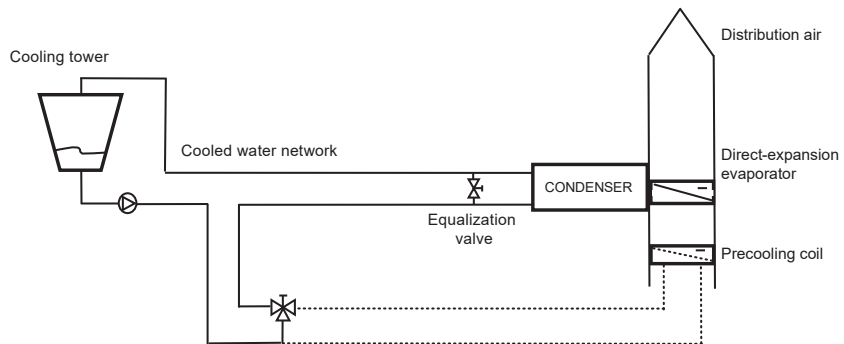
- evaporation cooling, also called “water precooling,” such as that shown in Figure A-5.2.2.9.-A, and
- sensible heat transfer cooling, also called “air precooling,” such as that shown in Figure A-5.2.2.9.-B.

The dotted lines represent the portion of the economizer system.



**Figure A-5.2.2.9.-A**

**Evaporation cooling economizer system – water precooling by a water economizer system**



**Figure A-5.2.2.9.-B**

**Sensible heat transfer cooling economizer system – air precooling by a water economizer system”.**

Add the following Notes:

**“A-5.2.3.1. and 5.2.6. Brake Horsepower, Rated Capacity and Power Demand.**

The capacity of a fan varies depending on the location where it is measured on a “fan, motor, variable-speed drive” set.

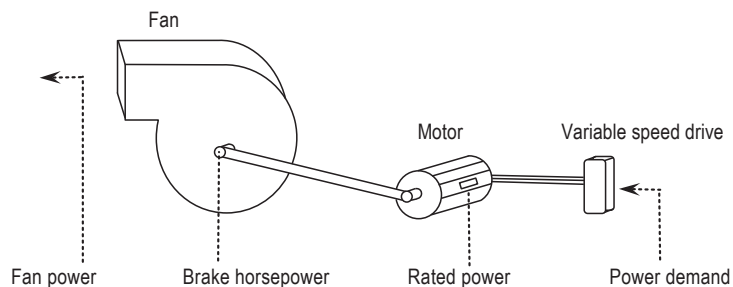
The brake horsepower is measured directly on the fan, on its drive shaft. It is sometimes expressed by the fan manufacturer in bhp. The brake horsepower is the power necessary to drive the fan blades.

The rated capacity is measured on the fan motor and is indicated on its nameplate. The rated capacity is the brake horsepower to which the power necessary to offset losses due to the strap and the internal losses of the electric motor is added.

The power demand is measured at the circuit breaker of the electrical panel. It is the electric power necessary to supply the “fan, motor, variable-speed drive” set. The power demand is the rated capacity to which the power necessary to offset the losses due to the variable-speed drive is added, where applicable.

For a “fan, motor, variable-speed drive” set, the brake horsepower is always less than the rated capacity, that is itself always less than the power demand.

Figure A-5.2.3.1. shows the various locations where the capacity of a fan can be measured.



**Figure A-5.2.3.1.**

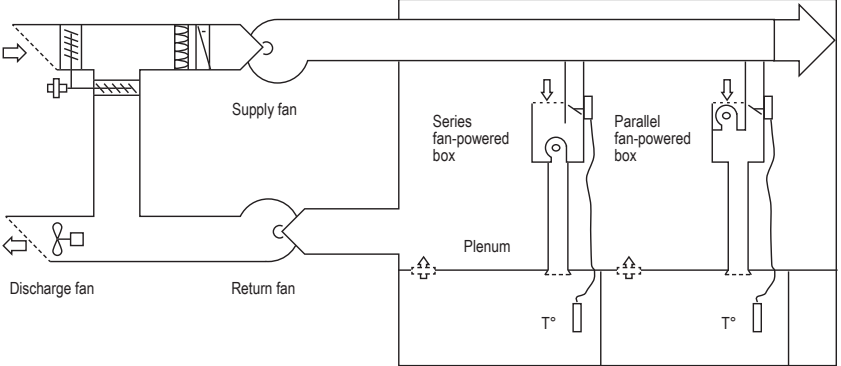
**Power that may be measured on the “fan, motor, variable-speed drive” set**

The pump capacities follow the same principles as those described above for fans, with the necessary modifications. For example, the power demand of a pump is also measured at the circuit breaker of an electrical panel. It is the electrical power necessary to supply the “turbine, motor, variable-speed drive” set.

**A-5.2.3.1.(1), (2) and (3) Application.** Fans to take into consideration in the calculation of the total of the powers are those that

- belong to the same HVAC system. Figure A-5.2.3.1.(1), (2) and (3) shows an example of an HVAC system with multiple fans. For example, if two HVAC systems have their own supply fans, their own heating and cooling coils and serve the same zone, they are considered to be two separate HVAC systems even if they serve the same zone. Two separate calculations must then be made to establish the total of the powers,



	<ul style="list-style-type: none"> <li>operate when the two design conditions, heating and cooling, are met. The power limit of 4 kW applies to fans whose total rated capacity is the highest between the heating conditions and the cooling conditions, and</li> <li>carry heated or cooled air. The calculation must take into account all the supply fans, return fans, relief fans, and fans for series fan-terminal zone boxes.</li> </ul> <p>Some fans may not be included in the calculation of the total of the power, such as the following:</p> <ul style="list-style-type: none"> <li>as mentioned in Clause 5.2.3.1.(3)(b), garage exhaust fans or server room transfer fans, where the spaces are not heated or cooled, and</li> <li>as mentioned in Sentence 5.2.3.1.(2), fans in parallel fan-terminal zone boxes where they do not operate at the cooling design conditions and the conditions are higher than the heating design conditions.</li> </ul>  <p>The diagram illustrates an HVAC system layout. On the left, a discharge fan is connected to a duct. A supply fan is connected to a main supply duct that runs horizontally across the top. Below the supply fan, a return fan is connected to a main return duct. A plenum is located between the supply and return ducts. Two vertical ducts branch off from the plenum, each leading to a fan-powered box. The first box is labeled 'Series fan-powered box' and the second is 'Parallel fan-powered box'. Both boxes have temperature sensors (T°) at their outlets. Arrows indicate the direction of airflow throughout the system.</p> <p><b>Figure A-5.2.3.1.(1), (2) and (3)</b>  <b>Example of an HVAC system with multiple fans”.</b></p>
<p><b>A-5.2.3.1.(2)</b></p>	<p>Strike out the Note.</p>
	<p>Add the following Note:</p> <p><b>“A-Table 5.2.3.1. Static Pressure Adjustments.</b> Multiple units and accessories in the ventilation system create a significant pressure loss and therefore require that the fan have a greater power to provide the flow required by the design conditions. The list of static pressure positive adjustments makes it possible to increase the limit of the allowed brake horsepower based on the accessories installed on the ventilation system. Certain adjustments are however negative and lower the power limit permitted.”.</p>
<p><b>A-5.2.3.2.(1)</b></p>	<p>Replace the Note by the following:</p>

	<p><b>“A-5.2.3.2.(1) Constant-Volume Fan Systems.</b> This type of system is found in particular in bypass variable-air-volume systems in which the airflow through the fan is not varied.”.</p>
	<p>Add the following Note:</p> <p><b>“A-5.2.3.2.(2) Maintenance of Pressure for Health or Safety Purposes.</b> Constant-volume systems are common in hospitals, vivariums and laboratories. If a room needs to be kept under negative pressure so as not to contaminate the other rooms, a control will open the exhaust or return duct damper of the said room and will close the damper of the other rooms. The fans of such a system may use the power limits of variable-air-volume fan systems.”.</p>
<b>A-5.2.3.3.(1)</b>	Strike out the Note.
	<p>Add the following Notes:</p> <p><b>“A-5.2.3.3. Variable-Air-Volume Fan Systems.</b> A fan that automatically varies the airflow based on static pressure is controlled from the sensors in each terminal zone box. Consequently, the following systems cannot be considered variable-air-volume fans and must use the limit of the constant-volume fan established in Article 5.2.3.2:</p> <ul style="list-style-type: none"> <li>• a constant-volume fan serving multiple zones and equipped with a bypass duct between its inlet and outlet (called “changeover bypass”),</li> <li>• a constant-volume fan serving multiple zones and equipped with terminal zone boxes bypassing supply air in the return plenum (called “bypass terminal unit”), and</li> <li>• a constant-volume fan for which a variable-speed drive is used only at airflow balancing.</li> </ul> <p><b>A-5.2.3.3.(2) Part-load Maximum Power.</b> Generally, a forward curved fan with inlet vanes or a variable-speed motor fan meets the requirement.</p> <p><b>A-5.2.3.3.(3) Location of Static Pressure Sensors.</b> In a variable-volume system, the location of a static pressure sensor is critical for the good operation of terminal zone boxes. The pressure upstream from the terminal zone box must be greater than the pressure loss caused by that same box; otherwise, the airflow at the outlet of the terminal zone box will be less than the specified airflow. A pressure too high upstream of the terminal zone box will generate noise and a higher energy use at the location of the fan. The location of a static pressure sensor is therefore a compromise between control and energy saving. To guarantee savings with respect to a variable-volume system, the Code requires that the sensor be located so that the static pressure setpoint be at a maximum of 300 Pa. That pressure is sufficient to carry sensor air to conditioned zones. Where the system includes multiple main branches and it is impossible to comply with the requirement in Subclause 5.2.3.3.(3)(b)(i), the use of a static pressure sensor will be necessary at each branch of the main duct.</p>

	<p><b>A-5.2.3.3.(4) Automatic Reset of Static Pressure Setpoint.</b> Where the terminal zone boxes are equipped with direct digital controls centralized at the main control panel of the supply fan, the highest pressure among all the conditioned spaces of the system is the ideal pressure to be developed by the fan. The conditioned space with the highest pressure generally corresponds to the space where the terminal zone box damper is the most open. That pressure is ideal because it allows all the terminal zone boxes to have an inlet pressure sufficient to operate correctly and it allows the supply fan to develop the weakest pressure possible to minimize energy consumption. In that context, the static pressure setpoint must be constantly adjusted to follow the ideal pressure under the requirements of Sentence 5.2.3.3.(4).”.</p>
<b>A-5.2.3.4.(1)</b>	Strike out the Note.
<b>A-5.2.3.4.(2)</b>	Strike out the Note.
<b>A-5.2.5.3.(1)</b>	<p>Add the following at the end of the Note:</p> <p>“<b>Piping</b> The accessories connected to pipes include in particular strainers and valves.”.</p>
	<p>Add the following Note:</p> <p>“<b>A-5.2.5.3.(3)(c) Piping in which the Fluid Conveyed is not Heated or Cooled by Electricity or Fossil Fuel.</b> Natural gas or condensate pipes are examples of piping in which the fluid conveyed is not heated or cooled by electricity or fossil fuel.”.</p>
<b>A-5.2.6.2.(1)</b>	<p>Replace the Note by the following:</p> <p>“<b>A-5.2.6.2.(1) Requirements for Pumping Systems for HVAC Systems.</b> During part-load operation, a constant-flow pumping system is more energy consuming because it uses three-way valves to divert the fluid from coils, thermal beams or any other type of appliance.</p> <p>Flow may be varied by one of several methods such as variable-speed-driven pumps, staged multiple pumps or pumps riding their performance curves, (i.e. uncontrolled pumps).”.</p>
<b>A-5.2.8.5.(1) and 5.2.11.1.(2)(e)</b>	Strike out the Note.

A-5.2.8.8.(2)	<p>Replace the Note by the following:</p> <p><b>“A-5.2.8.8.(2) Reheating Supply Air for Humidity Control.</b> Sentence 5.2.8.8.(2) could apply to server rooms, operating rooms in health care institutions and museums. For those buildings, dehumidification is usually carried out by cooling mixture air under the dew point required to maintain humidity at the specified rate. However, that temperature may be too low in relation to the setpoint temperature in the space, so that reheating would be required at the cooling coil outlet to do so.”.</p>
	<p>Add the following Note:</p> <p><b>“A-5.2.8.8.(3) Reheating Supply Air by Recovered Energy.</b> The energy rejected by the mechanical cooling system may be used to heat supply air without increasing the energy consumption of the building.”.</p>
A-5.2.8.9.(4)	<p>Strike out the Note.</p>
	<p>Add the following Notes:</p> <p><b>“A-5.2.8.9.(4) and (5) Zones with Limited Flow of Reheated, Cooled or Mixed Air.</b> Simultaneous heating and cooling are permitted by Sentences 5.2.8.9.(4) and 5.2.8.9.(5) where the flow, during heating, cooling or mixture, is limited. The maximum limit has been established by the minimum opening of terminal zone boxes of variable-volume built-up systems. That minimum opening is necessary to ensure a differential pressure adequate for the control of the terminal zone box. The limits have been established at 20% for digital control systems and at 30% for other control systems (such as pneumatic control systems).</p> <p><b>A-5.2.8.9.(6) Heat Recovery and Solar Energy.</b> The energy recovered at the site designates the heat recovered in the building to prevent energy consumption purchased from an energy supplier.</p> <p>Solar energy represents the thermal, chemical or electrical energy derived from the conversion of solar radiation. The conversion must be carried out on the site to prevent energy consumption purchased from an energy supplier.”.</p>
A-5.2.10.1.(1)	<p>Replace “of the exhaust/relief airstream, exhaust air recirculation, and the incoming ventilation airstream” in the Note by “of exhaust or relief air, exhaust air recirculation, and incoming ventilation air”;</p> <hr/> <p>Add the following Sentence at the end of the Note:</p> <p>“Sentence 5.2.10.1.(1) allows the HVAC system to be equipped with only one heat-recovery equipment for a number of exhaust equipment of a same system. The quantity of sensible heat of 50 kW is the sensible heat content of the total quantity of exhaust. If the HVAC system is equipped with more than one exhaust air system, the exhaust air from each system should be added.”.</p>

<b>A-5.2.10.1.(4)</b>	Strike out the Note.
<b>A-5.2.10.2.(1)</b>	Strike out the Note.
	<p>Add the following Notes:</p> <p><b>“A-5.2.10.2.(2) Heat Recovery from Exhaust Air from Swimming Pools.</b> Controlling humidity levels of the swimming pool with outdoor air is an energy consuming process and difficult to control in Québec’s climate. The purpose of Clause 5.2.10.2.(2)(a) is to limit to a minimum air renewal of the swimming pool. The heat recovery requirement in Clause 5.2.10.2.(2)(b) applies to a swimming pool even if the quantity of sensible heat recovered is less than the 50 kW limit in Sentence 5.2.10.1.(1).</p> <p><b>A-5.2.10.2.(3)(b) Heat Rejection from the Mechanical Dehumidification Equipment.</b> Heat rejection from the mechanical dehumidification equipment may be reused for heating swimming pool or shower water.”</p>
<b>A-5.2.10.3.(1)</b>	Strike out the Note.
	<p>Add the following Notes:</p> <p><b>“A-5.2.10.3.(1)(b) Heat Recovery from Grocery Store Refrigeration Systems.</b> The requirement covers in particular large surface grocery stores that often have a large number of food counters connected to a refrigeration system.</p> <p><b>A-5.2.10.3.(2)(a) Heat Recovery from Refrigeration Systems.</b> The heat at the condenser may usually be calculated by multiplying the cooler refrigeration capacity by its heat rejection factor.</p> <p><b>A-5.2.10.3.(2)(b) Heat Recovery.</b> Heat recovered from refrigeration equipment can also be used for ice resurfacing or heating the soil beneath the ice’s surface to prevent frost heave.”</p>
<b>A-5.2.10.4.(1)</b>	<p>Strike out the last sentence of the first Sentence of the Note;</p> <hr/> <p>Add the following Sentence at the end of the Note:</p> <p>“Supplementary exhaust fans such as kitchen hoods or bathroom fans need not comply with the heat- or energy-recovery requirements.”</p>

<b>A-5.2.10.4.(2)</b>	Strike out the Note.
	<p>Add the following Note:</p> <p><b>“A-5.2.10.4.(2)(a) Heat- or Energy-Recovery Ventilators.</b> CAN/CSA-C439, “Rating the Performance of Heat/Energy-Recovery Ventilators,” describes a laboratory test that determines the energy performance of a heat- or energy-recovery ventilator. Test results for many models are listed in HVI’s “Certified Home Ventilating Products Directory.” The results also usually appear on a label on the equipment itself or in the manufacturer’s published literature.”.</p>
<b>A-5.2.10.4.(5)</b>	Strike out the Note.
<b>A-5.2.11.1.(2)(d)</b>	Replace “Setback” by “Off-hour”.
<b>A-5.2.11.1.(2)(e)</b>	<p>Replace the Note by the following:</p> <p><b>“A-5.2.11.1.(2)(e) Heat Pump Controls for Recovery from Off-hours.</b> The requirements of Clause 5.2.11.1.(2)(e) can be achieved through several methods:</p> <ul style="list-style-type: none"> <li>• installation of a separate exterior temperature sensor limiting or stopping the operation of the supplementary heating element where the heat pump capacity is sufficient to ensure heating load,</li> <li>• setting a gradual rise of the temperature setpoint so that, at the end of the off-hours, the heat pump limits or stops the use of electrical backup, and</li> <li>• installation of controls that “learn” when to start recovery based on stored data, such as a start-stop optimization controller equipped with a self-learning function.”.</li> </ul>
	<p>Add the following Note:</p> <p><b>“A-5.2.11.2.(1) and (2) Airflow Control Area.</b> Large central HVAC systems often serve temperature-control zones occupied by different commercial tenants according to different schedules. Where one central system is present and only part of the zones is occupied, energy for conditioning the unoccupied zones is wasted. The purpose of Sentence 5.2.11.2.(1) is to force the designer to separate from other zones those that are not operated simultaneously. Zones thus grouped form an airflow control area that, according to Sentences 5.2.11.2.(2) to 5.2.11.2.(4), may not exceed 2300 m<sup>2</sup> and may not span more than one storey.</p> <p>Where the designer does not know the occupation schedule at the time of designing, an airflow control area for each commercial rental space is suggested.”.</p>

<b>A-5.2.11.2.(3)</b>	Strike out the Note.
	<p>Add the following Notes:</p> <p><b>A-5.2.11.2.(5) Control for Airflow Control Areas.</b> Each airflow control area must include controls that allow to consider the area as having a separate HVAC system. Each airflow control area can operate according to occupation schedules different from other areas. Control of each area may be carried out by</p> <ul style="list-style-type: none"> <li>• direct digital control systems installed on the terminal zone boxes,</li> <li>• terminal zone boxes “normally closed,” including a spring that closes the air supply damper where the terminal zone box actuator is no longer supplied with electricity, or</li> <li>• a motorized damper in the distribution duct.</li> </ul> <p><b>A-5.2.11.2.(7) Stable Operation of Fans and Associated HVAC Systems.</b> Dividing a central HVAC system into several airflow control areas requires that the designer design the system so that it operates adequately at part-load, e.g. for the whole time the smallest temperature-control zone is the only one occupied. During different zone occupation periods, the operation of the principal fan and the HVAC heating and cooling equipment must be stable, adapted to the different part-loads and designed to frequently cycle between stop and start.</p> <p><b>A-5.2.11.4.(1) Prevention of Heat Loss Between Boilers.</b> Some boilers have a bypass. Because those boilers are in operation, they need not comply with Sentence 5.2.11.4.(1).</p> <p><b>A-5.2.11.5.(1) Temperature Reset Methods.</b> The 88 kW design capacity in Sentence 5.2.11.5.(1) applies to a system with a chilled water loop, a hot water loop or both.</p> <p>Different methods allow the reset of the supply hot water loop temperature. For example, since the heating load of a building varies depending on outdoor temperature, an acceptable method could be the installation of a device that reduces the heating loop temperature where the outdoor temperature increases. However, that method on its own is not reliable for resetting the cooling loop temperature because most cooling loads do not vary on the basis of outdoor temperature.</p> <p>Another method consists in taking into account the actual heating or cooling load by resetting the heating or cooling loop temperature so that the coil valve that has the higher demand is maintained at its maximum opening. A variant of that method consists in estimating the average load of the loop using the return temperature.</p> <p><b>A-5.2.11.5.(2) Exemptions of HVAC Equipment and Systems.</b> Dehumidification systems that must operate continuously all year for health reasons, such as in a</p>

	<p>hospital, or for protecting art work, such as in a museum, are examples of systems that may use the exemption in Sentence 5.2.11.5.(2).</p> <p>However, a coil temperature ill-adapted to the loop reset may not be considered as an acceptable exemption. The designer must ensure that all equipment will operate once the loop temperature is reset. More specifically, equipment must be designed to operate correctly at the hottest temperature of a chilled water system and at the coldest temperature of the hot water system.”.</p>
<b>A-5.2.12.1.(1) and 6.2.2.1.(1)</b>	<p>Replace the heading of the Note by the following:  <b>“A-5.2.12.1.(1), 6.2.2.1.(1), 7.2.3.1.(1) and 7.2.4.1.(1) Performance Requirements and Levels.”;</b></p> <hr/> <p>Add the following Sentence at the end of the Note:          “In Québec, the Act respecting energy efficiency and energy conservation standards for certain products (chapter N-1.01) and its regulation, the Regulation respecting the energy efficiency of electrical or hydrocarbon-fuelled appliances (chapter N-1.01, r. 1), prohibits the manufacturing, offering, selling or leasing of an appliance or otherwise disposing of it by gratuitous or onerous title by way of a commercial transaction if the appliance does not conform to the applicable energy efficiency and energy conservation standards.”.</p>
<b>A-5.2.12.2.(1)</b>	Strike out the Note.
	<p>Add the following Notes:</p> <p><b>“A-5.2.13.1.(1) Make-up Air for Exhaust of Air by Hood.</b> It is possible to offset with outdoor air directly in the hood. However, several studies have shown that, where the percentage of outdoor air exceeds 10%, hood air exhaust significantly reduces contaminant capture which forces users to increase hood flow. That increase results in a higher consumption to ensure exhaust of air and offset with outdoor air.</p> <p><b>A-5.2.13.1.(2)(a) Transfer air.</b> Available transfer air is air that would have been discharged otherwise or that has first circulated in a space other than the kitchen.</p> <p><b>A-5.2.13.1.(2)(b)(i) On Demand Exhaust.</b> Cooking fumes may in particular be detected by smoke detectors, temperature detectors under the hood, cooktop temperature detectors or a combination of those detectors.</p> <p><b>A-5.4.1.2.(1) and (2) Limitations.</b> The HVAC systems and equipment listed in Sentence 5.4.1.2.(1) are covered by the prescriptive requirements in</p> <ul style="list-style-type: none"> <li>• Sentence 5.1.1.3.(2) for back-up HVAC systems,</li> <li>• Articles 5.2.2.1. to 5.2.2.6. for air duct systems,</li> <li>• Subsection 5.2.4. for air intake and outlet dampers,</li> </ul>



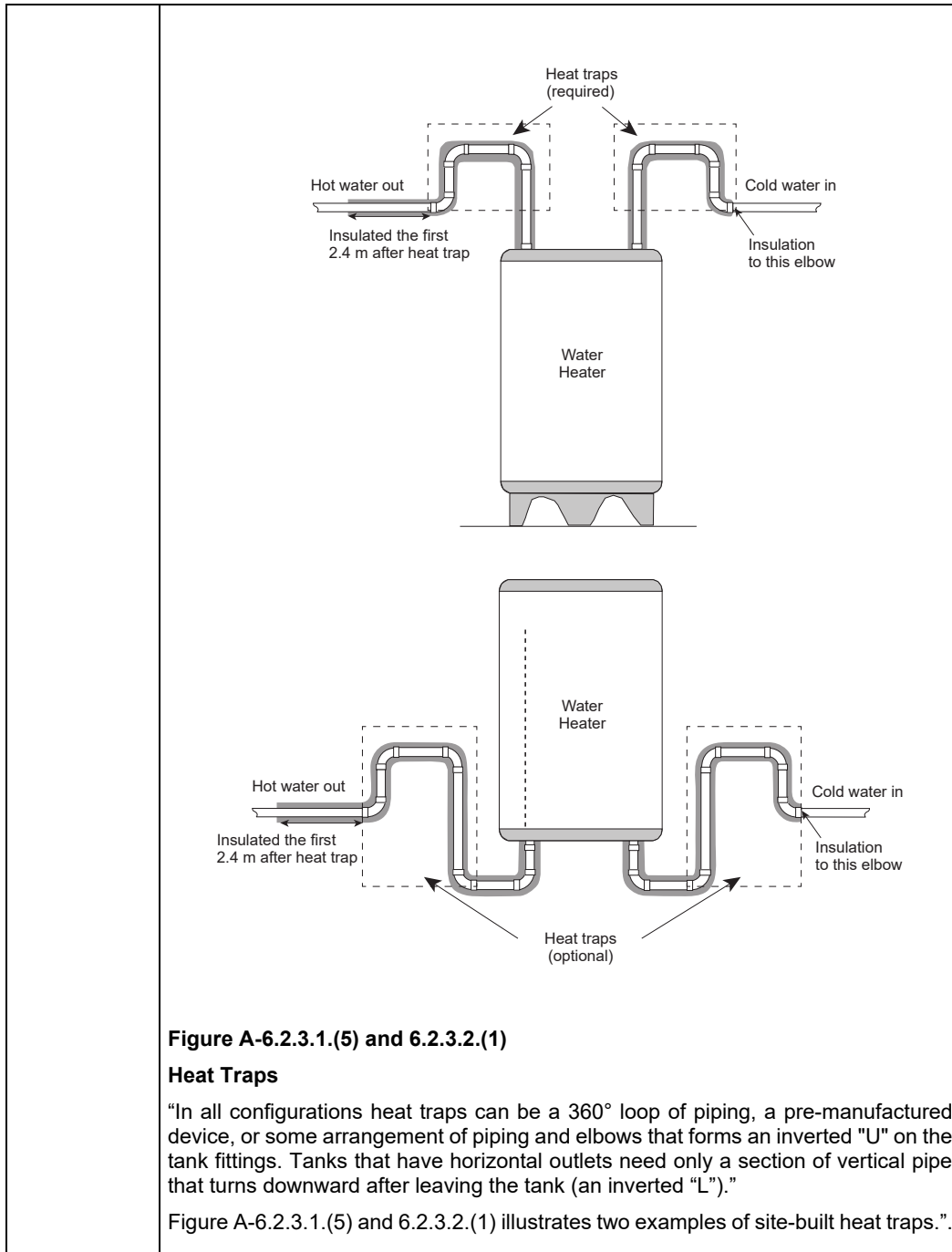
	<ul style="list-style-type: none"> <li>• Subsection 5.2.5. for piping for an HVAC system,</li> <li>• Article 5.2.8.5. for space temperature control, and</li> <li>• Article 5.2.11.2. for airflow control areas.”.</li> </ul>
<b>Division B Part 6</b>	Replace the heading of the Part by the following: <b>“Part 6 SERVICE WATER SYSTEMS AND SWIMMING POOLS”.</b>
<b>6.1.1.1.</b>	Replace Sentence (1) by the following: <b>“1) This Part applies</b> a) to the systems used to heat <i>service water</i> , b) to the pumping systems that are part of <i>service water</i> systems, and c) to swimming pools.”.
<b>6.1.1.2.</b>	Insert “and except as provided in Sentence (2)” after “firefighting services” in Sentence (1); <hr/> Add the following Sentence: <b>“2) This Part does not apply to existing parts of <i>service water</i> heating systems that are extended to serve <i>additions</i>.”.</b>
<b>6.2.2.1.</b>	Replace Sentence (1) by the following: <b>“1) Water heaters and pool heaters shall comply</b> a) with the efficiency requirements provided for in the Act respecting energy efficiency and energy conservation standards for certain products (chapter N-1.01) and its regulations, as well as Federal regulations, or b) in the absence of the requirements described in Clause (a), with the requirements listed in Table 6.2.2.1. (See Notes A-6.2.2.1.(1) and A-5.2.12.1.(1), 6.2.2.1.(1), 7.2.3.1.(1) and 7.2.4.1.(1).)”. <hr/>
<b>6.2.2.2.</b>	Replace Sentence (1) by the following: <b>“1) Hot <i>service water</i> storage tanks shall be covered with insulation having a minimum thermal resistance of 2.22 m<sup>2</sup>×K/W”.</b>
<b>6.2.2.4.</b>	Replace “22 kW” in Clause (1)(a) by “44 kW”; <hr/>

	<p>Insert the following at the end of Sentence (1): “(See Note A-6.2.2.4.(1).)”;</p> <hr/> <p>Replace “in the applicable standards listed in Tables 5.2.12.1.-A to 5.2.12.1.-P and 6.2.2.1. or, where such equipment is not covered in these Tables, with the “Energy Efficiency Act” and the “Energy Efficiency Regulations.”” in Sentence (2) by “in Sentences 5.2.12.1.(1) and 6.2.1.1.(1)”.</p>														
6.2.2.5.	<p>Replace “in the applicable standards listed in Tables 5.2.12.1.-A to 5.2.12.1.-P and 6.2.2.1. or, where such equipment is not covered in these Tables, with the “Energy Efficiency Act” and the “Energy Efficiency Regulations.”” in Sentence (1) by “in Sentences 5.2.12.1.(1) and 6.2.1.1.(1)”.</p>														
6.2.3.1.	<p>Replace Sentence (1) by the following:</p> <p><b>“1) All piping conveying hot <i>service water</i> in the following systems shall be insulated in accordance with Table 6.2.3.1. and Sentences (2) to (4):</b></p> <ul style="list-style-type: none"> <li>a) circulating systems,</li> <li>b) except as provided in Sentence (5), systems with a <i>storage heater</i>, and</li> <li>c) systems equipped with electrical elements along pipes to maintain the temperature in the pipes.”;</li> </ul> <hr/> <p>Replace Sentence (5) by the following:</p> <p><b>“5) In <i>service water</i> heating systems with a <i>storage-type service water heater</i>, non-circulating and equipped with <i>heat traps</i>, only the following piping sections shall be insulated in accordance with Table 6.2.3.1:</b></p> <ul style="list-style-type: none"> <li>a) hot water piping and cold water piping located between <i>heat traps</i> and the storage or expansion tank,</li> <li>b) the piping forming the <i>heat traps</i>, and</li> <li>c) the first 2.4 m of the hot water piping located after the <i>heat trap</i>.</li> </ul> <p>(See Note A-6.2.3.1.(5) and 6.2.3.2.(1).)”;</p> <hr/> <p>Replace Table 6.2.3.1. by the following:</p> <p style="text-align: center;"><b>“Table 6.2.3.1.</b>  <b>Minimum Thickness of Piping Insulation for Service Water Heating Systems</b>  Forming Part of Sentences 6.2.3.1.(1) to (3), (5) and (6)</p> <table border="1" data-bbox="355 1347 1173 1618"> <thead> <tr> <th rowspan="2">Location of Piping</th> <th colspan="2">Thermal Conductivity of Insulation</th> <th rowspan="2">Nominal Pipe Diameter, in. (mm)</th> <th rowspan="2">Minimum Thickness of Piping Insulation, mm</th> </tr> <tr> <th>Conductivity Range, W/m×°C</th> <th>Mean Rating Temperature, °C</th> </tr> </thead> <tbody> <tr> <td rowspan="2"><i>Conditioned space</i></td> <td rowspan="2">0.035 – 0.040</td> <td rowspan="2">38</td> <td>≤ 1 (≤ 25.4)</td> <td>25.4</td> </tr> <tr> <td>&gt; 1 (&gt; 25.4)</td> <td>38.1</td> </tr> </tbody> </table>	Location of Piping	Thermal Conductivity of Insulation		Nominal Pipe Diameter, in. (mm)	Minimum Thickness of Piping Insulation, mm	Conductivity Range, W/m×°C	Mean Rating Temperature, °C	<i>Conditioned space</i>	0.035 – 0.040	38	≤ 1 (≤ 25.4)	25.4	> 1 (> 25.4)	38.1
Location of Piping	Thermal Conductivity of Insulation		Nominal Pipe Diameter, in. (mm)	Minimum Thickness of Piping Insulation, mm											
	Conductivity Range, W/m×°C	Mean Rating Temperature, °C													
<i>Conditioned space</i>	0.035 – 0.040	38	≤ 1 (≤ 25.4)	25.4											
			> 1 (> 25.4)	38.1											

	<table border="1"> <tr> <td rowspan="3">Unconditioned space or space outside of the <i>building envelope</i></td> <td rowspan="3">0.046 – 0.049</td> <td rowspan="3">38</td> <td>≤ 2 (≤ 51)</td> <td>63.5</td> </tr> <tr> <td>&gt; 2 and ≤ 4 (&gt; 51 and ≤ 102)</td> <td>76.2</td> </tr> <tr> <td>&gt; 4 (&gt; 102)</td> <td>88.9</td> </tr> </table>	Unconditioned space or space outside of the <i>building envelope</i>	0.046 – 0.049	38	≤ 2 (≤ 51)	63.5	> 2 and ≤ 4 (> 51 and ≤ 102)	76.2	> 4 (> 102)	88.9
Unconditioned space or space outside of the <i>building envelope</i>	0.046 – 0.049				38	≤ 2 (≤ 51)	63.5			
						> 2 and ≤ 4 (> 51 and ≤ 102)	76.2			
		> 4 (> 102)	88.9							
	” .									
	<p>Add the following Articles:</p> <p><b>6.2.3.2. Heat Traps</b></p> <p>1) A <i>storage heater</i> or a storage tank serving a non-circulating system shall include a <i>heat trap</i> on the hot water piping and cold water piping. (See Note A-6.2.3.1.(5) and 6.2.3.2.(1).)</p> <p><b>6.2.3.3. Equipment for Protecting the Piping Against Freezing</b></p> <p>1) The equipment for protecting the piping located outside against freezing shall be equipped with automatic controls to shut down the equipment</p> <p>a) where the outdoor temperature is more than 4.4°C, or</p> <p>b) where there is no risk that the fluid in the protected piping will freeze.”.</p>									
<b>6.2.4.1.</b>	Strike out the Article.									
<b>6.2.6.</b>	Replace the Subsection by the following: “ <b>6.2.6. Deleted</b> ”.									
<b>6.2.7.2.</b>	Replace “have a nominal thermal transmittance of no more than 0.48 W/m <sup>2</sup> ×°C” in Sentence (2) by “shall have a thermal resistance of at least 2.08 (m <sup>2</sup> ×°C)/W”.									
<b>6.2.8.1.</b>	Strike out the Article.									
<b>6.4.1.2.</b>	<p>Replace the Article by the following:</p> <p><b>6.4.1.2. Limitations</b></p> <p>1) The performance path shall not take into consideration the energy performance of back-up <i>service water</i> heating systems.</p> <p>2) Back-up <i>service water</i> heating systems shall comply with Sentence 6.1.1.3.(2).”.</p>									

6.5.1.1.	<p>Insert, in numerical order, the following Articles, objectives and functional statements in Table 6.5.1.1.:</p> <p><b>“6.2.3.2. Heat Traps</b> (1) [F96-OE1.1]”;</p> <p><b>“6.2.3.3. Equipment for Protecting the Piping Against Freezing</b> (1) [F95-OE1.1]”;</p> <hr/> <p>Strike out the following Articles, objectives and functional statements in Table 6.5.1.1.:</p> <p><b>“6.2.4.1. Temperature Controls</b> (1) [F96-OE1.1]”;</p> <p><b>“6.2.6.1. Showers</b> (1) [F96-OE1.1] (2) [F96-OE1.1]”;</p> <p><b>“6.2.6.2. Lavatories</b> (1) [F96-OE1.1] (2) [F96-OE1.1]”;</p> <p><b>“6.2.8.1. Size of Water Storage Tank</b> (1) [F97,F99-OE1.1] (2) [F97,F99-OE1.1]”.</p>
<b>Division B</b> <b>Part 6</b> <b>Schedule A</b>	<p>Replace the heading of the Notes by the following:</p> <p><b>“Notes to Part 6</b>  <b>Service Water Systems and Swimming Pools”.</b></p>
	<p>Add the following Note:</p> <p><b>“A-6.2.2.4.(1) Combined Heating of Spaces and Service Water.</b> Systems designed to both heat space and heat service water meet respectively a seasonal load and a fixed load. In the summer, where only the hot service water fixed load must be satisfied, energy is wasted because the heating system is oversized in relation with the small hot service water load necessary. The purpose of Sentence 6.2.2.4.(1) is therefore to limit that practice.</p> <p>For example, if the system considered has a combined maximum input power of air heating and service water heating of 45 kW, Clause 6.2.2.4.(1)(b) must be complied with. To do so, the design service water heating load service water must be greater than half the power of the system, i.e. 22.5 kW.</p> <p>The requirement of Sentence (1) applies in particular to combined water heaters and to water heaters for which water is indirectly heated by a hot water system.”.</p>

<b>A-6.2.3.1.(1)</b>	Strike out the Note.
	Add the following Note: <b>“A-6.2.3.1.(5) and 6.2.3.2.(1) Heat Traps.</b> ASHRAE/IES 90.1, “User’s Manual,” defines a heat trap as follows: “A heat trap is a device or arrangement of piping that keeps the buoyant hot water from circulating through a piping distribution system through natural convection. By restricting the flow from the storage tank, standby heat loss is minimized.”



**Figure A-6.2.3.1.(5) and 6.2.3.2.(1)**

### Heat Traps

"In all configurations heat traps can be a 360° loop of piping, a pre-manufactured device, or some arrangement of piping and elbows that forms an inverted "U" on the tank fittings. Tanks that have horizontal outlets need only a section of vertical pipe that turns downward after leaving the tank (an inverted "L")."

Figure A-6.2.3.1.(5) and 6.2.3.2.(1) illustrates two examples of site-built heat traps."

<b>A-6.2.4.1.(1)</b>	Strike out the Note.
<b>A-6.2.6.1.(1)</b>	Strike out the Note.
<b>A-6.2.6.1.(2) and 6.2.6.2.(2)</b>	Strike out the Note.
<b>A-6.2.8.1.</b>	Strike out the Note.
<b>A-6.2.8.2.(1)</b>	<p>Replace the Note by the following:</p> <p><b>“A-6.2.8.2.(1) Sensors for Pressure Booster Systems.</b> Pressure booster systems should have one or more pressure sensors located near the fixtures that sets the system design pressure, or another type of sensor capable of estimating the pressure near the fixtures.”.</p>
<b>Division B Part 7</b>	<p>Replace the Part by the following:</p> <p><b>“Part 7</b>  <b>TRANSFORMERS AND ELECTRICAL MOTORS</b>  <b>Section 7.1. General</b>  <b>7.1.1. General</b>  <b>7.1.1.1. Scope</b>  1) This Part is concerned with transformers and electrical motors for the application listed in Article 7.1.1.2.  <b>7.1.1.2. Application</b>  1) Except as provided in Sentence (2), this Part applies to all transformers and electrical motors that are connected to the <i>building's</i> electrical service, including those installed outside the <i>building</i>.  2) This Part does not apply to existing transformers and electrical motors that are extended to serve <i>additions</i>.  <b>7.1.1.3. Compliance</b>  1) Compliance with this Part shall be achieved by following  a) the prescriptive path described in Section 7.2., or</p>

b) the performance path described in Section 7.4. (see Note A-3.1.1.3.(1)(c)).

#### **7.1.1.4. Definitions**

1) Words that appear in italics are defined in Article 1.4.1.2. of Division A.

### **Section 7.2. Prescriptive Path**

#### **7.2.1. Deleted**

#### **7.2.2. Deleted**

#### **7.2.3. Transformers**

##### **7.2.3.1. Transformer Selection**

1) Transformers shall comply with the efficiency requirements provided for in the Act respecting energy efficiency and energy conservation standards for certain products (chapter N-1.01) and its regulations, as well as Federal regulations. (See Notes A-6.2.2.1.(1) and A-5.2.12.1.(1), 6.2.2.1.(1), 7.2.3.1.(1) and 7.2.4.1.(1).)

#### **7.2.4. Electrical Motors**

##### **7.2.4.1. Efficiency**

1) Permanently wired polyphase motors serving the *building* shall comply with the efficiency requirements provided for in the Act respecting energy efficiency and energy conservation standards for certain products (chapter N-1.01) and its regulations, as well as Federal regulations. (See Notes A-6.2.2.1.(1) and A-5.2.12.1.(1), 6.2.2.1.(1), 7.2.3.1.(1) and 7.2.4.1.(1).)

### **Section 7.3. Reserved**

### **Section 7.4. Performance Path**

(See Note A-1.1.2.1.)

#### **7.4.1. General**

##### **7.4.1.1. Scope**

1) Where transformers and electrical motors do not comply with the requirements of Section 7.2., they shall comply with Part 8.

### **Section 7.5. Objective and Functional Statements**

#### **7.5.1. Objective and Functional Statements**

##### **7.5.1.1. Attributions to Acceptable Solutions**

1) For the purpose of compliance with this Code as required in Clause 1.2.1.1.(1)(b) of Division A, the objective and functional statements attributed to the acceptable



	<p>solutions in this Part shall be the objective and functional statements listed in Table 7.5.1.1. (See Note A-1.1.3.1.(1).)</p> <p style="text-align: center;"><b>Table 7.5.1.1.</b> <b>Objectives and Functional Statements Attributed to the Acceptable Solutions in Part 7</b> Forming Part of Sentence 7.5.1.1.(1)</p> <table border="1" data-bbox="423 342 864 508"> <thead> <tr> <th data-bbox="423 342 535 372">Provision</th> <th data-bbox="535 342 864 372">Functional Statements and Objectives<sup>(1)</sup></th> </tr> </thead> <tbody> <tr> <td colspan="2" data-bbox="423 372 864 408"><b>7.2.3.1. Transformer Selection</b></td> </tr> <tr> <td data-bbox="423 408 535 439">(1)</td> <td data-bbox="535 408 864 439">[F97,F98-OE1.1]</td> </tr> <tr> <td colspan="2" data-bbox="423 439 864 474"><b>7.2.4.1. Efficiency</b></td> </tr> <tr> <td data-bbox="423 474 535 508">(1)</td> <td data-bbox="535 474 864 508">[F97,F98,F99-OE1.1]</td> </tr> </tbody> </table> <p><b>Notes to Table 7.5.1.1.:</b> <sup>(1)</sup> See Parts 2 and 3 of Division A.”.</p>	Provision	Functional Statements and Objectives <sup>(1)</sup>	<b>7.2.3.1. Transformer Selection</b>		(1)	[F97,F98-OE1.1]	<b>7.2.4.1. Efficiency</b>		(1)	[F97,F98,F99-OE1.1]
Provision	Functional Statements and Objectives <sup>(1)</sup>										
<b>7.2.3.1. Transformer Selection</b>											
(1)	[F97,F98-OE1.1]										
<b>7.2.4.1. Efficiency</b>											
(1)	[F97,F98,F99-OE1.1]										
<p><b>Division B</b> <b>Part 7</b> <b>Schedule A</b></p>	<p>Strike out the Notes in Part 7.</p>										
<p><b>Division B</b> <b>Part 8</b></p>											
<p><b>8.1.1.1.</b></p>	<p>Replace Sentence (1) by the following: “<b>1</b>) Compliance with this Code is permitted to be achieved by applying the provisions of this Part. (See Note A-1.1.2.1.).”.</p>										
<p><b>8.1.1.2.</b></p>	<p>Add the following line after “<b>8.1.1.2. Application</b>”: “(See Note A-8.1.1.2.);”</p> <hr/> <p>Replace Sentence (1) by the following: “<b>1</b>) This Part applies only to <i>buildings</i></p> <ol style="list-style-type: none"> <li>a) whose function is known,</li> <li>b) for which the <i>building envelope</i> is defined in the plans and specifications, and</li> <li>c) except as provided in Sentence (2), for which sufficient information is known about their components, materials and assemblies that are covered by the scope of this Code.”;</li> </ol> <hr/> <p>Strike out “3.2.,” in Sentence (2).</p>										

8.4.1.	Add the following line after “ <b>8.4.1. Compliance</b> ”: “(See Note A-8.4.1.)”.
8.4.1.1.	<p>Replace Sentences (1) to (3) by the following:</p> <p>“<b>1)</b> The performance path shall take into consideration the energy needs of the <i>building</i> components in accordance with the prescriptive requirements of Sections 3.2., 4.2., 5.2., 6.2. and 7.2. for the climate zone under consideration.</p> <p><b>2)</b> Where the construction techniques, systems or <i>building</i> components used are more energy-efficient than those prescribed by the prescriptive requirements, the performance compliance calculations are permitted to take this increased performance level into account in the determination of the annual energy needs, provided it can be quantified and is not dependent on occupant behaviour.</p> <p><b>3)</b> <i>Exterior lighting</i> must be excluded from the performance compliance calculations.</p> <p><b>4)</b> The areas of <i>opaque building assemblies, fenestration</i> and doors shall be calculated in accordance with the requirements of Article 3.1.1.6.”.</p>
8.4.1.2.	<p>Replace “Sentences (2) to (5)” in Sentence (1) by “Sentences (2) to (4)”;</p> <hr/> <p>Replace Sentences (2) to (5) by the following:</p> <p>“<b>2)</b> The annual energy needs of the proposed <i>building</i> must not be greater than those of the reference <i>building</i> and must assessed as follows:</p> $2200 D_{\text{Prop}} + \text{AEC} \leq 2200 D_{\text{Ref}} + \text{BET}$ <p>where</p> <p><math>D_{\text{Prop}}</math> = the maximum power demand of the electrical system determined during one year, from 1 December to 31 March inclusively, analyzed using time intervals no greater than 15 minutes unless the calculation engine only offers 60-minute intervals, for the proposed <i>building</i>, in kW;</p> <p>AEC = the <i>annual energy consumption</i> of the proposed <i>building</i>, corresponding to the sum of the annual electricity needs, in kW × h, and the annual fuel needs, in kW×h equivalents;</p> <p><math>D_{\text{Ref}}</math> = the maximum power demand of the electrical system determined during one year, from 1 December to 31 March inclusively, analyzed using time intervals no greater than 15 minutes unless the calculation engine only offers 60-minute intervals, for the reference <i>building</i>, in kW; and</p> <p>BET = the <i>building energy target</i> of the reference <i>building</i> corresponding to the sum of the annual electricity needs, in kW×h, and the annual fuel needs, in kW×h equivalents.</p> <p><b>3)</b> The number of cumulative hours during which heating or cooling needs are not met shall not exceed 300 h in a simulated year for both the proposed and reference <i>buildings</i>. (See Note A-8.4.1.2.(3) and (4).)</p> <p><b>4)</b> The number of cumulative hours during which the heating or cooling needs of the proposed <i>building</i> are not met during a simulated year shall be less than or equal to</p>

	the number of hours corresponding to the reference <i>building</i> . (See Note A-8.4.1.2.(3) and (4).)”.
8.4.1.4.	<p>Replace the Article by the following:</p> <p><b>“8.4.1.4. Treatment of Additions</b></p> <p><b>1)</b> For the purpose of performance compliance calculations, the assessment of <i>additions</i> shall be based on the <i>addition</i> being considered by itself.</p> <p><b>2)</b> Where the HVAC systems of the existing <i>building</i> are extended to serve the <i>addition</i>, they shall be modeled for the proposed <i>building</i></p> <p>a) as if they met the prescriptive requirements of the Code, or</p> <p>b) using the characteristics of the existing system (see Note A-8.4.1.4.(2)(b)).</p> <p><b>3)</b> Where the party wall between the existing <i>building</i> and the <i>addition</i> divides <i>conditioned spaces</i> that must be maintained at temperatures varying by more than 10°C at design conditions, the thermal exchanges between the <i>addition</i> and the existing <i>building</i> shall be considered in the modeling. (See Note A-8.4.1.4.(3).)”.</p>
8.4.2.	<p>Add the following line after <b>“8.4.2. Compliance Calculations”</b>:</p> <p>“(See Note A-8.4.2.)”.</p>
8.4.2.2.	<p>Replace Sentences (1) to (5) by the following:</p> <p><b>“1)</b> Except as provided in Article 8.4.3.9., only the programs that have not shown any major failure or limitation following tests provided for in ANSI/ASHRAE 140, “Standard Method of Test for the Evaluation of Building Energy Analysis Computer Programs,” except Sections 7 and 8, may be used for the modeling provided for in this Part. (See Note A-8.4.2.2.(1).)</p> <p><b>2)</b> The same program shall be used to determine the maximum power demand of the electrical system and the <i>annual energy consumption</i> of the proposed <i>building</i>, as well as the maximum power demand of the electrical system and the <i>building energy target</i> of the reference <i>building</i>.</p> <p><b>3)</b> The programs shall</p> <p>a) consider the internal loads, in particular those due to occupants, activities and processes</p> <p>i) using actual values, when they are known, or</p> <p>ii) in the absence of actual values, using representative values (see Note A-8.4.3.8.(1)), and</p> <p>b) include the energy consumption of the systems that have an impact on the energy consumption of the <i>building</i>, including those of</p> <p>i) HVAC systems,</p> <p>ii) <i>interior lighting</i> devices,</p> <p>iii) <i>service water</i> heating equipment, and</p> <p>iv) elevators, moving walkways and escalators.</p>

	<p>(See Note A-8.4.2.2.(3).)</p> <p><b>4)</b> The programs shall account for</p> <p>a) sensible and latent heat transfers due to the internal loads in Sentence (3) other than those of <i>interior lighting</i> devices,</p> <p>b) the sensible heat transfer due to <i>interior lighting</i> devices</p> <p>i) in their illumination space, and</p> <p>ii) in return air of HVAC systems,</p> <p>c) the dynamic evolution of the temperature in the spaces,</p> <p>d) the effect of thermal mass, and</p> <p>e) air leaks through the <i>building envelope</i>.</p> <p><b>5)</b> The programs shall be performed for a one-year period (8760 h) using time intervals no greater than 1 h.</p> <p><b>6)</b> Operating schedules and climatic data input in the programs shall use a time interval no greater than 1 h.</p> <p><b>7)</b> The internal loads shall be adjusted for each time interval referred to in Sentence (5) based on the applicable operating schedules. (See Notes A-8.4.3.2.(1) and A-8.4.3.8.(1).)</p> <p><b>8)</b> Energy consumption of backup equipment is permitted to be excluded from the energy model, provided it is equipped with controls that operate the equipment only when the backed-up equipment is not operating.”.</p>
8.4.2.3.	<p>Replace Sentence (1) by the following:</p> <p>“<b>1)</b> The programs shall use as input climatic data whose temperature, humidity and insolation, derived from climatic data,</p> <p>a) were shown to be good representations of the climate at the <i>building</i> site compared to the average of at least 10 years of measured data, and</p> <p>b) were collected at the weather station nearest to the <i>building</i> site.”;</p> <hr/> <p>Replace “the energy model calculations shall be performed using” in Sentence (2) by “the programs shall consider as input”.</p>
8.4.2.4	Strike out the Article.
8.4.2.5.	Strike out the Article.
8.4.2.6.	<p>Replace the words “energy model calculations” wherever they appear in Sentences (1) and (2) by “programs”;</p> <hr/>

	Replace “solid <i>partitions</i> or solid <i>building elements</i> ” in Sentence (2) by “walls”.
<b>8.4.2.7.</b>	Strike out the Article.
<b>8.4.2.8.</b>	<p>Replace the Article by the following:</p> <p><b>“8.4.2.8. Building Envelope</b> (See Note A-8.4.2.8.)</p> <p><b>1)</b> Programs shall account for heat transfers through the <i>building envelope</i>, due to solar radiation and indoor and outdoor temperature difference of the <i>building envelope</i>.</p> <p><b>2)</b> Programs shall account for the thermodynamic behaviour of <i>opaque building assemblies</i> and other assemblies such as floors and interior walls.</p> <p><b>3)</b> Programs shall account for heat transfers due to solar absorptance and transmittance and the orientation and optical characteristics of each surface.</p> <p><b>4)</b> Except as provided in Sentence 8.4.3.3.(6), the values of the <i>effective thermal resistance of opaque building assemblies</i> of the proposed <i>building</i> and the reference <i>building</i> shall be derated using the following equation, whether or not the proposed <i>building envelope</i> complies with the requirements of Sentences 3.2.1.2.(1) to (7) and (10), using the values in Tables 8.4.2.8.-A and 8.4.2.8.-B (See Note A-8.4.2.8.(4)):</p> $RSI_{EDi} = \frac{1}{\frac{\sum_{j=1}^m (\Psi_j \times L_j) + \sum_{k=1}^n (\chi_k \times N_k)}{A_i} + \frac{1}{RSI_{Ei}}}$ <p>where</p> <p><math>RSI_{EDi}</math> = derated <i>effective thermal resistance of opaque building assembly i</i> of the proposed or reference building, in (m<sup>2</sup>×K)/W,</p> <p><math>\Psi_j</math> = <i>linear thermal transmittance</i> of the type j intersection calculated in accordance with Sentence 3.1.1.5.(7), in W/(m×K),</p> <p><math>L_j</math> = length of the type j intersection, in m,</p> <p>m = total number of types of intersections,</p> <p><math>\chi_k</math> = <i>point thermal transmittance</i> of the type k penetration calculated in accordance with Sentence 3.1.1.5.(7), in W/K,</p> <p><math>N_k</math> = number of type k point penetrations,</p> <p>n = total number of types of penetrations,</p> <p><math>A_i</math> = area of <i>opaque building assembly i</i>, calculated in accordance with Article 3.1.1.6., in m<sup>2</sup>, and</p> <p><math>RSI_{Ei}</math> = <i>effective thermal resistance</i> of the non-derated <i>opaque building assembly</i>, calculated in accordance with any of Sentences 3.1.1.5.(5) and (6), in (m<sup>2</sup>×K)/W.</p>

<b>Table 8.4.2.8.-A</b> <b>Default Linear Thermal Transmittance of Certain Intersections</b> Forming Part of Sentence 8.4.2.8.(4)		
Intersection	Maximum <i>Linear Thermal Transmittance</i> , $\Psi$ , in W/(m <sup>2</sup> ·K) Intersection of the reference <i>building</i> and the proposed <i>building</i> that complies with the prescriptive requirements	Maximum <i>Linear Thermal Transmittance</i> <sup>(1)</sup> , $\Psi$ , in W/(m <sup>2</sup> ·K) Intersection of the proposed <i>building</i> that does not comply with the prescriptive requirements
Wall/roof	0.325	0.800
Wall/intermediate floor	0.300	0.850
Wall/projection <sup>(1)</sup>	0.500	1.000
Wall/ <i>foundation</i>	0.450	0.850
Wall/opening or wall/wall, minor <sup>(2)</sup>	0.200	0.500
Wall/wall, major <sup>(3)</sup>	0.450	0.850
<b>Notes to Table 8.4.2.8.-A:</b>		
(1) Projections include linear penetrations that fully go through or partially penetrate the building assembly, extending on the exterior side of the building assembly (e.g. a balcony).		
(2) Minor intersections are intersections that generally result in moderate thermal loss.		
(3) Major intersections are intersections that may result in more significant thermal loss.		
<b>Table 8.4.2.8.-B</b> <b>Point Thermal Transmittance of Penetrations</b> Forming Part of Sentence 8.4.2.8.(4)		
	<i>Point Thermal Transmittance</i> , in W/K Penetration of the reference <i>building</i> and the proposed <i>building</i> that complies with the prescriptive requirements	<i>Point Thermal Transmittance</i> , in W/K Penetration of the proposed <i>building</i> that does not comply with the prescriptive requirements
Any penetration	0.5	1.0
<b>5) The derated <i>effective thermal resistance</i>, calculated in accordance with Sentence (4), may be determined for an entire <i>opaque building assembly</i>, provided that the adjacent <i>temperature-control zones</i> are maintained at temperatures that vary by not more than 10°C. (See Note A-8.4.2.8.(5).)</b>		
<b>8.4.2.9.</b>	Replace the Article by the following: <b>“8.4.2.9. Manually Operated Shading Devices</b> 1) The energy model shall not include the effect of manually operated shading devices such as blinds and shades.”.	
<b>8.4.2.10.</b>	Replace Sentences (1) to (5) by the following:	

	<p>“<b>1</b>) HVAC systems shall be modeled according to the established program conventions, without substituting their components with thermodynamically similar components or using approximated calculations.</p> <p><b>2</b>) Programs shall account for the effect of HVAC systems on supply and return air temperature and on that of <i>conditioned spaces</i> including</p> <ul style="list-style-type: none"> <li>a) temperature rise of air due to heat from constant, variable or multiple speed fans,</li> <li>b) fan power as a function of modulation of supply airflow,</li> <li>c) temperature or humidity rise or drop of supply or return air due to sensible and latent heat transferred from a heat-recovery device, and</li> <li>d) temperature rise of the outdoor air due to preheaters.</li> </ul> <p><b>3</b>) Programs shall account for the variation of efficiency and capacity of the HVAC systems as a function of part load of the systems. (See Note A-8.4.2.10.(3).)</p> <p><b>4</b>) Where the program requires an individual efficiency rate of an equipment component of an HVAC system, the global efficiency rate of the equipment shall be adjusted accordingly before being entered into the program. (See Note A-8.4.2.10.(4).)</p> <p><b>5</b>) Programs shall be able to assess the peak load according to the design conditions and to size accordingly the equipment and other components of the HVAC system.”.</p>
8.4.3.	<p>Replace the heading by the following:</p> <p><b>“8.4.3. Annual energy consumption and maximum power demand of the electrical system of the proposed building”.</b></p>
8.4.3.1.	<p>Replace Sentence (1) by the following:</p> <p>“<b>1</b>) The <i>annual energy consumption</i> and the maximum power demand of the electrical system of the proposed <i>building</i> must be calculated in accordance with this Subsection.”;</p> <hr/> <p>Replace “specifications” in Sentence (2) by “plans and specifications”;</p> <hr/> <p>Replace Clauses (2)(d) and (2)(e) by the following:</p> <ul style="list-style-type: none"> <li>“d) <i>service water</i> heating system types, capacities and controls,</li> <li>e) electrical systems, and</li> <li>f) the delimitation of <i>temperature-control zones</i>.”;</li> </ul> <hr/> <p>Strike out Sentences (3) to (8).</p>
8.4.3.2.	<p>Replace the Article by the following:</p> <p><b>“8.4.3.2. Operating Schedules</b></p>

	<p>1) The operating schedules of the energy model shall be established</p> <ol style="list-style-type: none"> <li>a) using the planned operating schedules, where they are known, or</li> <li>b) in the absence of planned operating schedules, using operating schedules representative of the type of proposed <i>building</i> or functions of spaces.</li> </ol> <p>(See Note A-8.4.3.2.(1).)”.</p>
8.4.3.3.	<p>Replace Sentences (2) to (4) by the following:</p> <p>“2) Where the modeler takes into account <i>fenestration</i> shading effects, the following conditions shall be complied with:</p> <ol style="list-style-type: none"> <li>a) the energy model shall include permanent shading devices, such as sun screens and reflective sills, and automated shading devices,</li> <li>b) the energy model shall include the surrounding shading effects from, for example, nearby <i>buildings</i> and landscaping elements,</li> <li>c) the energy model shall include the shading effects from the <i>building</i> itself, for example, caused by balconies, overhanging floors and the other wings of the <i>building</i>, and</li> <li>d) the solar heat gain and the visible solar transmittance coefficient of the <i>fenestration</i> of all the <i>building</i> shall be multiplied by an adjustment factor of 0.9.</li> </ol> <p>(See Note A-8.4.3.3.(2).)</p> <p>3) Where the modeler does not take into account <i>fenestration</i> shading effects,</p> <ol style="list-style-type: none"> <li>a) the solar heat gain coefficient and the visible solar transmittance coefficient of the <i>fenestration</i> of all the <i>building</i> shall be multiplied by an adjustment factor of 0.8 (see Note A-8.4.3.3.(3)(a)), and</li> <li>b) two adjacent outside surfaces whose azimuth or slope differ by not more than 45° may be modeled as a single surface.</li> </ol> <p>4) The air leakage rate of the total above-ground gross areas of walls and roofs shall be set to a constant value of 0.25 L/(s×m<sup>2</sup>). (See Note A-8.4.3.3.(4).)</p> <p>5) Where an <i>opaque building assembly</i> covers less than 5% of the total area of a wall or roof, the assembly may be excluded from the energy model, provided that the area is included in the adjacent <i>opaque building assembly</i> with</p> <ol style="list-style-type: none"> <li>a) an <i>effective thermal resistance</i> that differs by less than 20%, and</li> <li>b) an azimuth or slope that differs by not more than 45°.</li> </ol> <p>6) Where multiple <i>opaque building assemblies</i> have the same orientation, the energy model may use the same derated <i>effective thermal resistance</i> value for those assemblies, calculated as provided in Sentence 8.4.2.8.(4) using</p> <ol style="list-style-type: none"> <li>a) the following three values: <ol style="list-style-type: none"> <li>i) the least performing <i>effective thermal resistance</i>, <math>RS_{I_{Ei}}</math>, in (m<sup>2</sup>×K)/W, of the <i>opaque building assemblies</i>,</li> <li>ii) the least performing <i>linear thermal transmittance</i>, <math>\Psi</math>, in W/(m×K), of the <i>opaque building assemblies</i> for each of the types of intersections, and</li> <li>iii) the least performing <i>point thermal transmittance</i>, <math>\chi</math>, in W/K, of the <i>opaque building assemblies</i> for each of the types of penetrations, or</li> </ol> </li> </ol>



b) the following three values:

i) the weighted *effective thermal resistance*,  $RSI_{Eweighted}$ , in  $(m^2 \times K)/W$ , calculated using the following equation:

$$RSI_{Eweighted} = \frac{\sum_{i=1}^n (A_i)}{\sum_{i=1}^n \left( \frac{A_i}{RSI_{Ei}} \right)}$$

where

$n$  = total number of *opaque building assemblies*,

$A_i$  = area of *opaque building assembly*  $i$ , calculated in accordance with the requirements of Article 3.1.1.6., in  $m^2$ , and

$RSI_{Ei}$  = *effective thermal resistance* of *opaque building assembly*  $i$ , in  $(m^2 \times K)/W$ ,

ii) the weighted *linear thermal transmittance* for each of the types  $j$  intersections,  $\Psi_{weighted,j}$ , in  $W/(m \times K)$ , calculated using the following equation:

$$\Psi_{weighted,j} = \frac{\sum_{i=1}^n (\Psi_i \times L_i)}{\sum_{i=1}^n (L_i)}$$

where

$n$  = total number of *opaque building assemblies*,

$\Psi_i$  = *linear thermal transmittance* of the type  $j$  intersection present on *opaque building assembly*  $i$ , in  $W/(m \times K)$ , and

$L_i$  = length of the type  $j$  intersection occurring on *opaque building assembly*  $i$ , in  $m$ , and

iii) the weighted *point thermal transmittance* for each of the types  $j$  penetrations,  $\chi_{weighted,j}$ , in  $W/K$ , calculated using the following equation:

$$\chi_{weighted,j} = \frac{\sum_{i=1}^n (\chi_i \times N_i)}{\sum_{i=1}^n (N_i)}$$

where

$n$  = total number of *opaque building assemblies*,

$\chi_i$  = *point thermal transmittance* of the type  $j$  penetration occurring on *opaque building assembly*  $i$ , in  $W/K$ , and

$N_i$  = number of type  $j$  point penetrations occurring on the *opaque building assembly*.

7) Performance exchanges with *opaque building assemblies* in contact with the ground may be considered in the model on the following conditions:

a) the program shall not use methods based on regression analyses or on analytical calculations to calculate the annual heat transfer of *opaque building assemblies* in contact with the ground,

b) the program shall permit accurate modeling of the arrangement of the insulation and the properties of *opaque building assemblies* in contact with the ground, and

c) the calculation methods implemented by the programs shall be identical for the proposed and reference *buildings*.

	<p>(See Note A-8.4.3.3.(7).)</p> <p><b>8)</b> Where the <i>effective thermal resistance</i> of the opaque section of curtain walls has not been determined in accordance with Sentence 3.1.1.5.(6), the values in Sentence 3.3.1.3.(4) shall be used in the proposed <i>building</i>.”.</p>														
<p><b>8.4.3.4.</b></p>	<p>Replace Sentences (2) to (4) by the following:</p> <p>“<b>2)</b> Where the proposed <i>building</i> contains controls based on space occupancy, personal controls or photocontrols, the lighting power connected to the control shall be multiplied by the factor for occupancy control, <math>F_{occ,i}</math>, the factor for personal control, <math>F_{pers,i}</math>, and the factor for photocontrol, <math>F_{pho}</math>, as determined in accordance with the following equations:</p> <p>a) for the factor for occupancy control, <math>F_{occ,i}</math>:</p> $F_{occ,i} = 1 - (C_{A,i} \times C_{occ,ctrl,i})$ <p>where</p> <p><math>C_{A,i}</math> = factor to account for the relative absence of occupants in the space determined using Table 8.4.3.4.-A,</p> <p><math>C_{occ,ctrl,i}</math> = factor to account for the occupancy-sensing mechanism determined using Table 8.4.3.4.-B,</p> <p>b) for the factor for personal control, <math>F_{pers,i}</math>:</p> $F_{pers,i} = 1 - C_{pers,ctrl,i}$ <p>where</p> <p><math>C_{pers,ctrl,i}</math> = factor to account for personal control determined using Table 8.4.3.4.-A, and</p> <p>c) for the factor for photocontrol, <math>F_{pho,i}</math>:</p> $F_{pho,i} = 1 - C_{pho,i}$ <p>where</p> <p><math>C_{pho,i}</math> = factor to account for the reduction of photocontrol power determined in accordance with Sentence (3).</p> <p>(See Note A-8.4.3.4.(2).)</p> <p style="text-align: center;"><b>Table 8.4.3.4.-A</b>  <b>Factors for Relative Absence of Occupants and Personal Control According to Space Type</b>      Forming Part of Sentence 8.4.3.4.(2)</p> <table border="1" data-bbox="355 1293 1188 1609"> <thead> <tr> <th rowspan="2">Space Types</th> <th colspan="2">Factors</th> </tr> <tr> <th>Relative Absence of Occupants, <math>C_{A,i}</math></th> <th>Personal Control<sup>(1)</sup>, <math>C_{pers,ctrl,i}</math></th> </tr> </thead> <tbody> <tr> <td colspan="3" style="text-align: center;"><b>Common Space Types</b></td> </tr> <tr> <td>Atrium</td> <td style="text-align: center;">0</td> <td style="text-align: center;">0 0.1 where C2</td> </tr> <tr> <td>Audience seating area – permanent  for auditorium</td> <td style="text-align: center;">0.3</td> <td style="text-align: center;">0</td> </tr> </tbody> </table>	Space Types	Factors		Relative Absence of Occupants, $C_{A,i}$	Personal Control <sup>(1)</sup> , $C_{pers,ctrl,i}$	<b>Common Space Types</b>			Atrium	0	0 0.1 where C2	Audience seating area – permanent  for auditorium	0.3	0
Space Types	Factors														
	Relative Absence of Occupants, $C_{A,i}$	Personal Control <sup>(1)</sup> , $C_{pers,ctrl,i}$													
<b>Common Space Types</b>															
Atrium	0	0 0.1 where C2													
Audience seating area – permanent  for auditorium	0.3	0													

	for convention centre	0.2	0
	for gymnasium	0	0
	for motion picture <i>theatre</i>	0	0
	for penitentiary	0	0
	for performing arts <i>theatre</i>	0	0
	for religious <i>building</i>	0.3	0
	for sports arena	0	0
	other	0	0
	Banking activity area and offices	0	0
	Classroom/Lecture hall/Training room		
	for penitentiary	0.5	0 0.1 where C2
	other	0.5	0 0.1 where C2
	Conference/Meeting/Multi-purpose room	0.5	0 0.1 where C2
	Confinement cell	0	0
	Copy/Print room	0.2	0
	Corridor/Transition area		
	for hospital	0	0 0.1 where C2
	for manufacturing facility	0	0 0.1 where C2
	for space designed to ANSI/IES RP-28, "Lighting and the Visual Environment for Senior Living" (and used primarily by residents)	0	0 0.1 where C2
	other	0	0 0.1 where C2
	Courtroom	0.2	0 0.1 where C2
	Dining area		
	for bar lounge/leisure dining	0	0 0.1 where C2
	for cafeteria/fast food dining	0	0 0.1 where C2
	for family dining	0	0 0.1 where C2
	for penitentiary	0	0 0.1 where C2
	for space designed to ANSI/IES RP-28, "Lighting and the Visual Environment for Senior Living" (and used primarily by residents)	0	0 0.1 where C2

other	0	0 0.1 where C2
Dressing/Fitting room for performing arts <i>theatre</i>	0.4	0
Electrical/Mechanical room	0.9	0
Emergency vehicle garage	0.5	0 0.1 where C2
Food preparation area	0	0
Guest room	0	0
Laboratory		
for classroom	0.4	0 0.1 where C2
other	0	0
Laundry/Washing area	0	0
Loading dock – interior	0	0
Lobby		
for elevator	0	0 0.1 where C2
for hotel	0	0 0.1 where C2
for motion picture <i>theatre</i>	0	0 0.1 where C2
for performing arts <i>theatre</i>	0	0 0.1 where C2
for space designed to ANSI/IES RP-28, "Lighting and the Visual Environment for Senior Living" (and used primarily by residents)	0	0 0.1 where C2
other	0	0 0.1 where C2
Locker room	0.5	0
Lounge/Break room		
for health care facility	0	0
other	0	0
Office		
enclosed	0.3	0 0.05 where C1 or C2
open plan	0.2	0 0.05 where C1 or C2 0.25 where C3 0.3 where C4
Pharmacy area	0	0
Sales area	0	0
Seating area - general	0	0

Computer/Server room	0.7	0
Stairway, except stairwell	0	0
Stairwell	0	0
Storage garage - interior	0.4	0 0.1 where C2
Storage room	0.6	0
Vehicle maintenance area	0	0
Washroom  for space designed to ANSI/IES RP-28, "Lighting and the Visual Environment for Senior Living" (and used primarily by residents)	0.5	0
other	0.5	0
Workshop	0	0
<b>Building-Specific Space Types</b>		
Convention centre – exhibit space	0	0
Dormitory – living quarters	0	0
Fire station – sleeping quarters	0	0
Gymnasium/Fitness centre  exercise area	0	0.1 where C2
playing area	0	0.1 where C2
Health care facility  exam/treatment room	0.3	0
imaging room	0	0
medical supply room	0.5	0
nursery	0	0
nurses' station	0	0
operating room	0.1	0
patient room	0.1	0
physical therapy room	0.2	0
recovery room	0	0
Library  reading area	0	0

	stacks	0	0
	Manufacturing facility		
	detailed manufacturing area	0	0
	equipment room	0.2	0
	extra high bay area (> 15 m floor-to-ceiling height)	0	0
	high bay area (7.5 m to 15 m floor-to-ceiling height)	0	0
	low bay area (< 7.5 m floor-to-ceiling height)	0	0
	Museum		
	general exhibition area	0.2	0
	restoration room	0.3	0
	Post office - sorting area	0	0
	Religious <i>building</i>		
	fellowship hall	0.3	0
	worship/pulpit/choir area	0.1	0
	Retail facility		
	dressing/fitting room	0.4	0
	mall concourse	0	0 0.1 where C2
	Space designed to ANSI/IES RP-28, "Lighting and the Visual Environment for Senior Living"		
	chapel (used primarily by residents)	0.5	0
	recreation room (used primarily by residents)	0.2	0
	Sports area – playing area		
	playing area with facilities for more than 5000 spectators	0	0
	playing area with facilities for more than 2000 spectators and not more than 5000 spectators	0	0
	playing area with facilities for more than 200 spectators and not more than 2000 spectators	0	0
	playing area with facilities for less than	0	0

200 spectators or without a facility for spectators		
Transportation facility		
airport concourse	0	0
baggage/carousel area	0	0
terminal ticket counter	0	0
Warehouse – storage area		
medium to bulky palletized items	0.5	0
small hand-carried items <sup>(2)</sup>	0.5	0

**Notes to Table 8.4.3.4.-A:**

<sup>(1)</sup> Controls C1, C2, C3 and C4 are defined in Table 4.2.1.6.

<sup>(2)</sup> See Note A-Table 4.2.1.6.

**Table 8.4.3.4.-B**  
**Factor to Account for Occupancy-Sensing Mechanism,  $C_{occ,ctrl,i}$**   
 Forming Part of Sentence 8.4.3.4.(2)

Occupancy-Sensing Mechanism	$C_{occ,ctrl,i}$
Automatic full off (full on)	0.67
Automatic full off (restricted to manual on or automatic partial on)	0.75
Automatic partial off (restricted to manual on)	0.34
Manual (on/off or bi-level)	0.30
None	0

**Table 8.4.3.4.-C**  
**Factor to Account for Reduction of Photocontrol Power,  $C_{pho,i}$**   
 Forming Part of Sentence 8.4.3.4.(3)

Photocontrol Mechanism	$C_{pho,i}$
Bi-level photocontrol	0.1
Continuous dimming photocontrol	0.3
Multi-level photocontrol	0.2
None	0

**3)** The factor for photocontrol,  $F_{pho,i}$ , may be determined by

- a) Table 8.4.3.4.-C, or
- b) a program whose functions consist in performing detailed calculations of daylighting and the dynamic response of photocontrols.

**4)** The use of the factor for photocontrol,  $F_{pho,i}$ , is permitted to reduce the *installed interior lighting power*

- a) where lighting devices are in a daylighted space and are connected to photocontrols, and
- b) where the setpoint of lighting devices connected to photocontrols is representative of the use of the space without task lighting.

(See Note A-8.4.3.4.(4).)”.’

8.4.3.5.	<p>Replace “a gas-fired” in Sentence (2) by “an electrical”;</p> <hr/> <p>Replace Clause (2)(b) by the following:  “b) has a constant efficiency of 100% independently from the load.”;</p> <hr/> <p>Replace “a gas-fired” in Sentence (4) by “an electrical”;</p> <hr/> <p>Replace “Forming Part of Sentences 8.4.3.5.(3) and 8.4.4.6.(2)” under the heading of Table 8.4.3.5. by the following:  “Forming Part of Sentence 8.4.3.5.(3)”;</p> <hr/> <p>Replace Clause (4)(b) by the following:  “b) has a constant efficiency of 100% independently from the load, and”;</p> <hr/> <p>Insert “proposed” before “storage tank” in Clause (4)(c).</p>
8.4.3.6.	<p>Replace the Article by the following:  <b>“8.4.3.6. HVAC Systems</b></p> <p><b>1)</b> The program shall provide that the exhaust airflow and outdoor air ventilation of each HVAC system are not less than the minimum outdoor airflow required for acceptable indoor air quality as prescribed by the NBC. (See Note A-8.4.3.6.(1).)</p> <p><b>2)</b> Part-load operation of HVAC system’s equipment of the proposed <i>building</i> shall be modeled</p> <p>a) from the equipment technical characteristics, where they are known and the program is able to model the part load of HVAC system’s equipment, or</p> <p>b) in other cases</p> <p>i) in accordance with the performance curves under part load in Subsection 8.4.5., or</p> <p>ii) with the operating curves under default part load provided for in the programs provided that they are representative.</p> <p>(See Note A-8.4.3.6.(2).)</p>
8.4.3.7.	<p>Replace the Article by the following:  <b>“8.4.3.7. Temperature-Control Zones</b></p> <p><b>1)</b> Each <i>temperature-control zone</i> of the proposed <i>building</i> shall be modeled in one of the following manners:</p> <p>a) heated, if only heating HVAC systems are provided or planned,</p>



	<p>b) cooled, if only cooling HVAC systems are provided or planned, or</p> <p>c) heated and cooled, if heating and cooling HVAC systems are provided or planned.</p> <p><b>2)</b> Except as provided in Sentence (4), where the spaces served by the HVAC system are specified in the plans and specifications, each space shall be modeled as a single <i>temperature-control zone</i>.</p> <p><b>3)</b> Except as provided in Sentence (4), where the spaces served by the HVAC system are not entirely specified in the plans and specifications, the spaces shall be modeled in several <i>temperature-control zones</i> delimited as follows:</p> <p>a) an indoor <i>temperature-control zone</i>, delimited at 4.5 m from the outdoor glazed facade,</p> <p>b) one or more peripheral <i>temperature-control zones</i> delimited between</p> <p>i) the indoor <i>temperature-control zone</i> in Clause (a),</p> <p>ii) the outdoor glazed facades, and</p> <p>iii) the location where the azimuth of an outdoor glazed facade varies by more than 45° in relation to another adjacent outdoor glazed facade, and</p> <p>c) <i>temperature-control zones</i> delimited by <i>storey</i>.</p> <p>(See Note A-8.4.3.7.(3).)</p> <p><b>4)</b> The grouping of <i>temperature-control zones</i> in <i>thermal blocks</i> is permitted.”.</p>
8.4.3.8.	<p>Replace the Article by the following:</p> <p><b>“8.4.3.8. Internal and Service Water Heating Loads</b></p> <p><b>1)</b> The internal loads and the needs in <i>service water</i> used in calculating energy compliance shall be representative of the functions of the spaces or the type of proposed <i>building</i>. (See Note A-8.4.3.8.(1).)”.</p>
8.4.3.9.	<p>Replace the Article by the following:</p> <p><b>“8.4.3.9. Energy Recovered on Site and Renewable Energy Produced on Site</b></p> <p><b>1)</b> Where the proposed <i>building</i> uses technologies for recovering energy that is not required in Subsection 5.2.10., it is permitted to subtract that energy from the <i>annual energy consumption</i> if it is not intended for sale. (See Note A-8.4.3.9.(1) and (2).)</p> <p><b>2)</b> Where the proposed <i>building</i> uses technologies for producing renewable energy on site, it is permitted to subtract that energy from the <i>annual energy consumption</i>, up to 5% of the <i>annual energy consumption</i>, if it is not intended for sale. (See Note A-8.4.3.9.(1) and (2).)</p> <p><b>3)</b> Where the program in Article 8.4.2.2. does not have the function of modeling the technology in Sentences (1) and (2), it is permitted to quantify the energy recovered on site or the renewable energy produced on site by using another tool or another calculation method covering a one-year period (8760 h).”.</p>
8.4.4.	<p>Replace the heading by the following:</p>

	<p><b>“8.4.4. Building energy target and maximum power demand of the electrical system of the reference building”.</b></p>
<p><b>8.4.4.1.</b></p>	<p>Replace Sentence (1) by the following:  <b>“1) The <i>building energy target</i> and the maximum power demand of the electrical system of the reference <i>building</i> must be calculated based on the parameters described in this Subsection.”;</b></p> <hr/> <p>Add “(See Note A-8.4.4.1.(2).)” at the end of Sentence (2);</p> <hr/> <p>Insert “and Subsection 8.4.3.” after “this Subsection” in Sentence (4);</p> <hr/> <p>Replace Clauses (4)(c) to (4)(e) by the following:</p> <p>“c) number, type and need for heating or cooling <i>thermal blocks</i> and <i>temperature-control zones</i>,</p> <p>d) shape and exterior dimensions, including contiguous ground level,</p> <p>e) orientation,</p> <p>f) air leakage rates,</p> <p>g) solar heat gain coefficient and visible solar transmittance coefficient of <i>fenestration</i>,</p> <p>h) <i>fenestration</i> shading effects due to surrounding elements and those from the <i>building</i> itself,</p> <p>i) insulation arrangement and <i>effective thermal resistance</i> of <i>opaque building assemblies</i> in contact with the ground,</p> <p>j) thermal mass of <i>building envelope</i>,</p> <p>k) operating schedules,</p> <p>l) setpoint temperatures and humidity of spaces,</p> <p>m) setpoint <i>service water</i> heating temperature,</p> <p>n) temperature of water from the public distribution network or a private source,</p> <p>o) plug loads,</p> <p>p) values associated to activities and processes, such as power, energy sources and heat produced,</p> <p>q) HVAC systems associated only to processes,</p> <p>r) densities of <i>installed interior lighting power</i> of <i>dwelling units</i>,</p> <p>s) factor for occupancy control determined in accordance with Clause 8.4.3.4.(2)(a),</p> <p>t) radiating and convective distribution of heat gains emitted by lighting,</p> <p>u) <i>interior lighting</i> for the functions, spaces or equipment referred to in Sentence 4.2.1.4.(4),</p>

	<p>v) occupancy densities,  w) sensible heat and latent heat produced by occupants,  x) location, orientation and dimensions of <i>fenestration</i> and doors, and  y) thermal properties of ground, such as thermal conductivity, specific heat and density.  (See Note A-8.4.4.1.(4).)";</p> <hr/> <p>Replace Sentences (5) to (7) by the following:  <b>5)</b> Climatic data used in compliance calculations for the proposed <i>building</i> shall be applied as being identical in the reference <i>building</i>.  <b>6)</b> Where the proposed <i>building</i> uses an energy source, that energy source shall also be present for the same purposes in the modeling of the reference <i>building</i>.  <b>7)</b> Where the proposed <i>building</i> uses more than one energy source, the power ratios between the energy sources and priority of use of those sources in the proposed <i>building</i> shall be modeled as being identical in the reference <i>building</i>.  <b>8)</b> Except as provided in Sentence (9), the energy efficiency of the reference <i>building</i> equipment shall  a) comply with Sentences 5.2.12.1.(1), 6.2.2.1.(1), 7.2.3.1.(1) and 7.2.4.1.(1), or  b) in the absence of applicable values under Clause (a), be identical to that of the proposed <i>building's</i> corresponding equipment.  (See Note A-8.4.4.1.(8) and (9).)  <b>9)</b> The use, in modeling the reference <i>building</i>, of the minimum equipment energy efficiency provided for in the Energy Efficiency Act (S.C. 1992, c. 36) and its regulations, is permitted  a) where that equipment is covered by the Energy Efficiency Act (S.C. 1992, c. 36) and its regulations, and  b) where that equipment is not covered by the Act respecting energy efficiency and energy conservation standards for certain products (chapter N-1.01) and its regulations.  (See Note A-8.4.4.1.(8) and (9).)";</p>
8.4.4.2.	Strike out the Article.
8.4.4.3.	<p>Replace Sentences (1) to (8) by the following:  <b>1)</b> The solar absorptance of <i>opaque building assemblies</i> shall be set at 0.7.  <b>2)</b> Where, in the proposed <i>building</i>,  a) the ratio in Sentence 3.2.1.4.(1) is greater than 40%, the ratio shall be set, in the reference <i>building</i>, at 40% of the gross wall area  i) by proportionally reducing the area of each of the doors and each of the <i>fenestration</i> elements, excluding <i>skylights</i>, and</p>

	<p>ii) so that the relative opening proportion on each of the proposed <i>building</i> orientations is identical to that of the reference <i>building</i>, and</p> <p>b) the ratio in Sentence 3.2.1.4.(2) is greater than 3%, the ratio shall be set, in the reference <i>building</i>, at 3% of the gross roof area by proportionally reducing the area of each of the <i>skylights</i>.</p> <p><b>3) Permanent fenestration shading devices and projections shall not be modeled in the reference <i>building</i>. (See Note A-8.4.4.3.(3).)</b></p> <p><b>4) Where performance exchanges with opaque building assemblies in contact with the ground shall be considered in the proposed <i>building</i>, in accordance with Sentence 8.4.3.3.(7), those assemblies shall be modeled in the reference <i>building</i> so as to comply with the requirements of Subsection 3.2.3.”.</b></p>
8.4.4.4.	<p>Replace Sentence (1) by the following:</p> <p>“<b>1)</b> The thermal characteristics of the reference <i>building's building envelope</i> is permitted to be modeled as being identical to those of lightweight construction having a weight of 55 kg/m<sup>2</sup> and a thermal capacity of 50 kJ/(m<sup>2</sup>×°C). (See Note A-8.4.4.4.(1).)”.</p>
8.4.4.5.	<p>Replace Sentence (3) by the following:</p> <p>“<b>3)</b> Where controls based on space occupancy are provided in the proposed <i>building</i>, the lighting power related to that control in the reference <i>building</i> shall be multiplied by the same factor for occupancy control, <math>F_{occ,i}</math>, as determined in accordance with Article 8.4.3.4. for the appropriate occupancy-sensing mechanism.”;</p> <hr/> <p>Strike out Sentences (4) to (12).</p>
8.4.4.6.	<p>Replace the Article by the following:</p> <p><b>“8.4.4.6. HVAC Systems and Service Water Heating Systems</b></p> <p><b>1)</b> The reference <i>building's</i> corresponding equipment shall be modeled in accordance with the requirements in Sentences 8.4.3.5.(2) to (5)</p> <p>a) where the heating equipment of the proposed <i>building</i> uses purchased energy, or</p> <p>b) where the cooling equipment of the proposed <i>building</i> uses purchased energy.</p> <p><b>2)</b> Where the proposed <i>building</i> uses a heat pump for heating, the reference <i>building's</i> corresponding equipment shall</p> <p>a) be sized for the peak heating load of the heating system, in accordance with Sentence 8.4.2.10.(5), and</p> <p>b) use electricity as energy source and be modeled</p> <p>i) in a hydronic loop compliant with the requirements of Sentence 8.4.4.9.(2), where the heat pump is on a water loop, a water-source or ground-source, or</p>

	<p>ii) as equipment with an electric resistance in accordance with the requirements of Sentence 8.4.4.9.(4), in the case of an air-source heat pump.</p> <p>(See Note A-8.4.4.6.(2) and (3).)</p> <p><b>3)</b> Where the proposed <i>building</i> uses a heat pump for cooling, the reference <i>building's</i> corresponding equipment shall be a chiller and shall</p> <p>a) be sized for the peak cooling load of the cooling system, in accordance with Sentence 8.4.2.10.(5),</p> <p>b) use electricity as energy source and be modeled as</p> <p>i) an air chiller, in accordance with Sentence 8.4.4.10.(2), where the heat pump is a water-source or ground-source heat pump,</p> <p>ii) a water chiller, in accordance with Sentence 8.4.4.10.(2), where the heat pump is a water-loop heat pump, or</p> <p>iii) a direct-expansion chiller, in accordance with Sentence 8.4.4.10.(3), where the heat pump is an air heat pump, and</p> <p>c) have a COP varying depending on the load.</p> <p>(See Note A-8.4.4.6.(2) and (3).)</p> <p><b>4)</b> The capacity or flow of an equipment of the HVAC system of the reference <i>building</i> shall be proportionally adjusted according to the corresponding equipment sizing factor of the proposed <i>building's</i> equipment calculated based on the procedure described in ASHRAE/IES 90.1, "User's Manual" (see Note A-8.4.4.6.(4)).</p> <p><b>5)</b> The performance characteristics of HVAC systems and <i>service water</i> heating devices shall be modeled in accordance with part-load performance curves in Subsection 8.4.5.</p> <p><b>6)</b> The reference <i>building's</i> fans of the HVAC system shall</p> <p>a) comply with the requirements of Subsection 5.2.3., or</p> <p>b) where Subsection 5.2.3 does not apply, have a "peak/flow power demand" identical to that of the proposed <i>building's</i> corresponding fans.</p> <p><b>7)</b> The reference <i>building's</i> HVAC systems shall comply with the requirements of Subsection 5.2.10.</p> <p><b>8)</b> Where the proposed <i>building</i> is provided with a commercial cooking ventilation system, the system referred to in Sentence 5.2.13.1.(2) shall be modeled in the reference <i>building</i> so that exhaust and compensation flows are reduced to 50% of the rated flows during half of the operating hours.</p> <p><b>9)</b> The equipment of the HVAC system modeled in the reference <i>building</i> shall be controlled in accordance with the requirements of Subsection 5.2.8.".</p>
--	---

Replace Sentences (1) to (4) by the following:

“1) Each HVAC system of the proposed *building* shall have a corresponding HVAC system for the reference *building* determined in accordance with Sentences (2) to (4).

2) Except as stated otherwise in this Subsection, each air distribution system modeled in the proposed *building* shall be present in the modeling of the reference *building*. (See Note A-8.4.4.7.(2) and (3).)

3) Except as stated otherwise in this Subsection, each hydronic loop of the proposed *building* shall be present in the modeling of the reference *building*. (See Note A-8.4.4.7.(2) and (3).)

4) Each HVAC system of the proposed *building* shall be modeled using the reference *building's* corresponding HVAC system, determined in accordance with Table 8.4.4.7.-A, the corresponding descriptions shown in Tables 8.4.4.7.-B to 8.4.4.7.-E.

**Table 8.4.4.7.-A**  
**HVAC System Selection for the Reference Building**  
Forming Part of Sentence 8.4.4.7.(4)

HVAC system of the proposed <i>building</i>			HVAC system of the reference <i>building</i>
Type of Dominating Cooling <sup>(1)</sup> supplied to one or a number of <i>Temperature-control zones</i>	Type of Dominating Heating <sup>(1)</sup> supplied to one or a number of <i>Temperature-control Zone</i>	Outdoor Air Supplied :	
Central system distributing air	Central system distributing heating air or air heated by one or more terminal zone boxes	One <i>temperature-control zone</i>	S1a/S1b – Single-zone
		Several <i>temperature-control zones</i>	S2a/S2b – Multi-zone
	Forced convection terminal system	One <i>temperature-control zone</i>	S1a/S1b/S1c – Single-zone
		Several <i>temperature-control zones</i>	S2a/S2b/S2c – Multi-zone
	Single natural convection perimeter system	One <i>temperature-control zone</i>	S1a/S1b – Single-zone
		Several <i>temperature-control zones</i>	S2a/S2b – Multi-zone
Forced convection terminal system	Central system distributing heating air or air heated by one or more terminal zone boxes	One <i>temperature-control zone</i>	S1c – Single-zone
		Several <i>temperature-control zones</i>	S2c – Multi-zone
	Forced convection terminal system	One <i>temperature-control zone</i>	S3a – 100% outdoor air with local ventilation
		Several <i>temperature-control zones</i>	S3b – 100% outdoor air with local ventilation

8.4.4.7.

	Single natural convection perimeter system	One <i>temperature-control zone</i>	S3a – 100% outdoor air with local ventilation
		Several <i>temperature-control zones</i>	S3b – 100% outdoor air with local ventilation
Induction terminal system <sup>(2)</sup>	All types of heating	One <i>temperature-control zone</i>	S1b – Single-zone
		Several <i>temperature-control zones</i>	S2b – Multi-zone
No cooling	Central system distributing heating air or air heated by one or more terminal zone boxes	One <i>temperature-control zone</i>	S1d – Single-zone
		Several <i>temperature-control zones</i>	S2d – Multi-zone
	Forced convection terminal system	One <i>temperature-control zone</i>	S3a – 100% outdoor air with local ventilation
		Several <i>temperature-control zones</i>	S3b – 100% outdoor air with local ventilation
	Single natural convection perimeter system	One <i>temperature-control zone</i>	S4a – 100% outdoor air without local ventilation
		Several <i>temperature-control zones</i>	S4b – 100% outdoor air without local ventilation

**Notes to Table 8.4.4.7.-A:**

<sup>(1)</sup> System that takes most of the heating or cooling load, as the case may be.

<sup>(2)</sup> See Note A-Table 8.4.4.7.-A.

**Table 8.4.4.7.-B**

S1a, S1b, S1c and S1d Systems – Single-zone, Single-sleeve, Constant Flow  
Forming Part of Sentences 8.4.4.7.(4) and 8.4.4.18.(3)

Description	Constant-air-volume system that varies the supply temperature. Control of the system is provided by a zone thermostat.  It may be a combined heating and conditioning system installed on the roof or an integrated system served by a chiller-boiler assembly.
Supply airflow	Constant, as defined in Article 8.4.4.18.
Supply air temperature	Variable according to the load of the <i>temperature-control zone</i> .
Supply fan	S1a – If the cooling system of the proposed <i>building</i> is direct-expansion, the supply fan must provide a static pressure of 325 Pa and have a combined energy efficiency of at least 40%.
	S1b – If the cooling system of the proposed <i>building</i> is hydronic, the supply fan must provide a static pressure of 500 Pa and have a combined energy efficiency of at least 50%.
	S1c and S1d – If cooling or heating of the zone is provided <u>only</u> by a forced or natural convection system, or if the proposed <i>building</i> does not have a cooling system, the

	<p>supply fan must provide a static pressure of 200 Pa and have a combined energy efficiency of at least 40%.</p> <p>For S1a, S1b, S1c and S1d:</p> <ul style="list-style-type: none"> <li>– if the proposed <i>building</i> has a return fan, the reference <i>building</i> shall be modeled with a return fan providing a static pressure of 150 Pa and having an energy efficiency of at least 25%;</li> <li>– possibility of adjusting the reference static pressure in accordance with Sentence 8.4.4.18.(3).</li> </ul>
Local fan	<p>S1c –Fan providing the cooling or heating forced convection of the zone. The fan must provide a power of 0.6 W/L/s.</p> <p>Operates on demand when the system is operating.</p>
Outdoor air	<p>As described in Article 8.4.4.15.</p> <p>Where Article 5.2.2.7. applies, the supply is 100% of outdoor air controlled by a fixed dry bulb in accordance with Table 5.2.2.8.-A. The economizer system is integrated with the mechanical cooling in accordance with Article 5.2.2.7.(3).</p>
Operating schedule	As described in Article 8.4.3.2.
Heating system	As described in Article 8.4.4.9.
Cooling system	As described in Article 8.4.4.10.
<p><b>Table 8.4.4.7.-C</b>  <b>S2a, S2b, S2c and S2d Systems – Multi-zone, Single-sleeve, Variable Flow</b>            Forming Part of Sentences 8.4.4.7.(4) and 8.4.4.18.(3)</p>	
Description	<p>Variable-air-volume and constant supply temperature system. The airflow is determined by the zone variable-air-volume terminal zone boxes.</p> <p>It may be a combined heating and conditioning system installed on the roof or an integrated system served by a chiller-<i>boiler</i> assembly type.</p>
Terminal zone boxes	<p>If the proposed <i>building's temperature-control zone</i> is supplied by terminal zone boxes with fan,</p> <ul style="list-style-type: none"> <li>– refer to Sentence 8.4.4.17.(5) to size the minimum and maximum flow of the terminal zone box,</li> <li>– the terminal zone box fan must provide a combined power of 0.74 W/L/s.</li> </ul> <p>If the proposed <i>building's temperature-control zone</i> is supplied by terminal zone boxes without fan,</p> <ul style="list-style-type: none"> <li>– refer to Sentence 8.4.4.17.(4) to size the minimum and maximum flow of the terminal zone box,</li> <li>– if the terminal zone box is controlled by a direct digital control system, the static pressure setpoint shall be adjusted in accordance with Sentence 5.2.3.3.(5).</li> </ul>
Supply airflow	Variable, maximum flow as defined in Article 8.4.4.18.
Supply air temperature	<p>Variable according to outdoor temperature,</p> <ul style="list-style-type: none"> <li>– if the outdoor temperature is less than 13°C, the supply temperature is 18°C;</li> <li>– if the outdoor temperature is greater than 18°C, the supply temperature is 13°C;</li> <li>– where the outdoor temperature is between 13°C and 18°C, the supply temperature varies linearly between 18°C and 13°C.</li> </ul>



Supply fan	<p>S2a – If the proposed <i>building</i>'s cooling system is direct-expansion, the supply fan must provide a static pressure of 750 Pa and have a combined energy efficiency of 45%;</p> <p>if the proposed <i>building</i> has a return fan, the reference <i>building</i> shall be modeled with a return fan providing a static pressure of 150 Pa and have an energy efficiency of at least 25%.</p>	
	<p>S2b – If the proposed <i>building</i>'s cooling system is hydronic, the supply fan must provide a static pressure of 1000 Pa and have a combined energy efficiency of 55%;</p> <p>if the proposed <i>building</i> has a return fan, the reference <i>building</i> shall be modeled with a return fan providing a static pressure of 250 Pa and have an energy efficiency of at least 45%.</p>	
	<p>S2c and S2d – If the zone cooling or heating is provided only by a forced or natural convection system, or if the proposed <i>building</i> does not have a cooling system, the supply fan must provide a static pressure of 620 Pa and have a combined energy efficiency of 40%;</p> <p>if the proposed <i>building</i> has a return fan, the reference <i>building</i> shall be modeled with a return fan providing a static pressure of 150 Pa and have an energy efficiency of at least 25%.</p>	
	<p>For S2a, S2b, S2c and S2d:</p> <ul style="list-style-type: none"> <li>– possibility of adjusting the reference static pressure as described in Sentence 8.4.4.18.(3),</li> <li>– part-load curve as described in Article 8.4.5.11.,</li> <li>– the supply fan shall be modeled as a forward curved fan with inlet vanes.</li> </ul>	
	Local fan	<p>S2c – System fan providing the cooling or heating forced convection of the zone. The fan shall provide a power of 0.6 W/Ls.</p> <p>Operates on demand where the system is operating.</p>
	Outdoor air	<p>As described in Article 8.4.4.15.</p> <p>Where Article 5.2.2.7. applies, the supply is 100% outdoor air controlled by a fixed dry bulb in accordance with Table 5.2.2.8.-A. The economizer system is integrated with the mechanical cooling in accordance with Article 5.2.2.7.(3).</p>
	Operating schedule	As described in Article 8.4.3.2.
Heating system	As described in Article 8.4.4.9.	
Cooling system	As described in Article 8.4.4.10.	
<p><b>Table 8.4.4.7.-D</b>  <b>S3a, S3b Systems – 100% Outdoor Air with Local Ventilation for Heating</b>            Forming Part of Sentences 8.4.4.7.(4) and 8.4.4.18.(3)</p>		
Description	System conveying 100% outdoor air to the <i>temperature-control zone</i> .	
Outdoor airflow	Constant, as defined in Article 8.4.4.18.	
Supply air temperature	Identical to that of the proposed <i>building</i> .	
Supply fan (100% outdoor air)	Operates continually when the system is operating.	
	S3a – If the supply fan supplies only that <i>temperature-control zone</i> , the supply fan must provide a static pressure of 150 Pa and have a combined energy efficiency (fan-motor-drive) of at least 20%, without return fan.	

	<table border="1"> <tr> <td></td> <td>S3b – If the supply fan supplies several <i>temperature-control zones</i>, the supply fan must provide a static pressure of 325 Pa and have a combined energy efficiency of at least 40%, without return fan.</td> </tr> <tr> <td></td> <td>Possibility of adjusting the static pressure as described in Sentence 8.4.4.18.(3).</td> </tr> <tr> <td>Local fan</td> <td>Fan providing a power of 0.6 W/L/s. Operates on demand where the system is operating.</td> </tr> <tr> <td>Outdoor air</td> <td>As described in Article 8.4.4.15.</td> </tr> <tr> <td>Operating schedule</td> <td>As described in Article 8.4.3.2.</td> </tr> <tr> <td>Heating system</td> <td>As described in Article 8.4.4.9.</td> </tr> <tr> <td>Cooling system</td> <td>As described in Article 8.4.4.10.</td> </tr> </table>		S3b – If the supply fan supplies several <i>temperature-control zones</i> , the supply fan must provide a static pressure of 325 Pa and have a combined energy efficiency of at least 40%, without return fan.		Possibility of adjusting the static pressure as described in Sentence 8.4.4.18.(3).	Local fan	Fan providing a power of 0.6 W/L/s. Operates on demand where the system is operating.	Outdoor air	As described in Article 8.4.4.15.	Operating schedule	As described in Article 8.4.3.2.	Heating system	As described in Article 8.4.4.9.	Cooling system	As described in Article 8.4.4.10.					
	S3b – If the supply fan supplies several <i>temperature-control zones</i> , the supply fan must provide a static pressure of 325 Pa and have a combined energy efficiency of at least 40%, without return fan.																			
	Possibility of adjusting the static pressure as described in Sentence 8.4.4.18.(3).																			
Local fan	Fan providing a power of 0.6 W/L/s. Operates on demand where the system is operating.																			
Outdoor air	As described in Article 8.4.4.15.																			
Operating schedule	As described in Article 8.4.3.2.																			
Heating system	As described in Article 8.4.4.9.																			
Cooling system	As described in Article 8.4.4.10.																			
	<p><b>Table 8.4.4.7-E</b>  <b>S4a, S4b Systems – 100% Outdoor Air without Local Ventilation for Heating</b>  Forming Part of Sentences 8.4.4.7.(4) and 8.4.4.18.(3)</p>																			
	<table border="1"> <tr> <td>Description</td> <td>System conveying 100% outdoor air to the <i>temperature-control zone</i>.</td> </tr> <tr> <td>Outdoor airflow</td> <td>Constant, as described in Article 8.4.4.18.</td> </tr> <tr> <td>Supply air temperature</td> <td>Identical to that of the proposed <i>building</i>.</td> </tr> <tr> <td rowspan="4">Supply fan (100% outdoor air)</td> <td>Operates continually when the system is operating.</td> </tr> <tr> <td>S4a – If the supply fan supplies only that <i>temperature-control zone</i>, the supply fan must provide a static pressure of 150 Pa and have a combined energy efficiency (fan-motor-drive) of at least 20%, without return fan.</td> </tr> <tr> <td>S4b – If the supply fan supplies several <i>temperature-control zones</i>, the supply fan must provide a static pressure of 325 Pa and have a combined energy efficiency of at least 40%, without return fan.</td> </tr> <tr> <td>Possibility of adjusting the static pressure as described in Sentence 8.4.4.18.(3).</td> </tr> <tr> <td>Outdoor air</td> <td>As described in Article 8.4.4.15.</td> </tr> <tr> <td>Operating schedule</td> <td>As described in Article 8.4.3.2.</td> </tr> <tr> <td>Heating system</td> <td>As described in Article 8.4.4.9.</td> </tr> <tr> <td>Cooling system</td> <td>As described in Article 8.4.4.10.</td> </tr> </table>	Description	System conveying 100% outdoor air to the <i>temperature-control zone</i> .	Outdoor airflow	Constant, as described in Article 8.4.4.18.	Supply air temperature	Identical to that of the proposed <i>building</i> .	Supply fan (100% outdoor air)	Operates continually when the system is operating.	S4a – If the supply fan supplies only that <i>temperature-control zone</i> , the supply fan must provide a static pressure of 150 Pa and have a combined energy efficiency (fan-motor-drive) of at least 20%, without return fan.	S4b – If the supply fan supplies several <i>temperature-control zones</i> , the supply fan must provide a static pressure of 325 Pa and have a combined energy efficiency of at least 40%, without return fan.	Possibility of adjusting the static pressure as described in Sentence 8.4.4.18.(3).	Outdoor air	As described in Article 8.4.4.15.	Operating schedule	As described in Article 8.4.3.2.	Heating system	As described in Article 8.4.4.9.	Cooling system	As described in Article 8.4.4.10.
Description	System conveying 100% outdoor air to the <i>temperature-control zone</i> .																			
Outdoor airflow	Constant, as described in Article 8.4.4.18.																			
Supply air temperature	Identical to that of the proposed <i>building</i> .																			
Supply fan (100% outdoor air)	Operates continually when the system is operating.																			
	S4a – If the supply fan supplies only that <i>temperature-control zone</i> , the supply fan must provide a static pressure of 150 Pa and have a combined energy efficiency (fan-motor-drive) of at least 20%, without return fan.																			
	S4b – If the supply fan supplies several <i>temperature-control zones</i> , the supply fan must provide a static pressure of 325 Pa and have a combined energy efficiency of at least 40%, without return fan.																			
	Possibility of adjusting the static pressure as described in Sentence 8.4.4.18.(3).																			
Outdoor air	As described in Article 8.4.4.15.																			
Operating schedule	As described in Article 8.4.3.2.																			
Heating system	As described in Article 8.4.4.9.																			
Cooling system	As described in Article 8.4.4.10.																			
<b>8.4.4.8.</b>	Strike out the Article.																			

8.4.4.9.	<p>Replace Sentences (1) to (8) by the following:</p> <p><b>“1)</b> Where the proposed <i>building’s</i> HVAC system has no heating capacity, the reference <i>building’s</i> corresponding HVAC system shall have no heating capacity.</p> <p><b>2)</b> Where, in the proposed <i>building</i>, the heating system is hydronic, the reference <i>building’s</i> corresponding heating system shall be modeled using a hydronic loop on the following conditions:</p> <ul style="list-style-type: none"> <li>a) the heating system shall be <ul style="list-style-type: none"> <li>i) a single-stage <i>boiler</i>, where the heating capacity is not more than 176 kW,</li> <li>ii) a two-stage <i>boiler</i>, the lowest stage operating first at 50%, where the heating capacity is more than 176 kW but not more than 352 kW, or</li> <li>iii) a modulating <i>boiler</i> between 25% and 100% of its capacity, where the heating capacity is more than 352 kW,</li> </ul> </li> <li>b) the pumping system shall be modeled by a variable-flow pump on a single primary water loop, and that pump shall <ul style="list-style-type: none"> <li>i) ride its performance curve, or</li> <li>ii) be variable-speed when the pumping system is referred to in Clause 5.2.6.1.(1)(a),</li> </ul> </li> <li>c) the peak pumping flow rate shall be sized using the following parameters: <ul style="list-style-type: none"> <li>i) the heating capacity of the <i>boiler</i>,</li> <li>ii) a heat transfer fluid supply temperature of 82°C, and</li> <li>iii) a heat transfer fluid return temperature of 54°C (see Note A-8.4.4.9.(2)(c), 8.4.4.10.(2)(d) and 8.4.4.11.(4)(b)),</li> </ul> </li> <li>d) the peak pumping power demand shall be identical to the sum of the peak pumping power demands used for the proposed <i>building</i> heating loop (see Note A-8.4.4.9.(2)(d), 8.4.4.10.(2)(e) and 8.4.4.11.(4)(c)), and</li> <li>e) the hot water supply temperature shall be set to <ul style="list-style-type: none"> <li>i) at least 82°C for an outside air temperature of not more than -16°C, and</li> <li>ii) not more than 60°C for an outside air temperature of at least 0°C.</li> </ul> </li> </ul> <p><b>3)</b> Where the heating system of the proposed <i>building</i> is a <i>furnace</i>, the reference <i>building’s</i> corresponding heating system shall be a <i>furnace</i> and it shall be modeled as follows:</p> <ul style="list-style-type: none"> <li>a) where the heating capacity is not more than 66 kW, the <i>furnace</i> shall be modeled as a two-stage heating device of equal capacity, and</li> <li>b) where the heating capacity is more than 66 kW, the <i>furnace</i> shall be modeled as a device whose number of heating stages is equal to its capacity divided by 66 kW, then rounded to the next whole number.</li> </ul> <p><b>4)</b> Where the heating system of the proposed <i>building</i> is an electric resistance, the reference <i>building’s</i> corresponding heating system shall be an electric resistance having a constant efficiency of 100% independently of load.”.</p>
----------	--

**8.4.4.10.**

Replace Sentences (1) to (9) by the following:

**1)** Where the proposed *building's* HVAC system has no cooling capacity, the reference *building's* corresponding HVAC system shall have no cooling capacity.

**2)** Where the cooling system of the proposed *building's* is hydronic, the cooling system of the reference *building* shall be hydronic and shall be modeled according to the following conditions:

- a) the number and type of chillers shall be determined using Table 8.4.4.10.,
- b) a single primary chilled water loop shall be modeled with as many pumps as there are chillers defined in Clause (a),
- c) the pumping system shall be modeled with variable flow, and its pumps shall
  - i) ride their performance curve, or
  - ii) be variable-speed where the pumping system is referred to in Clause 5.2.6.1.(1)(a),
- d) the peak pumping flow shall be sized using the following parameters:
  - i) the total cooling capacity of the reference *building's* system,
  - ii) a heat transfer fluid supply temperature of 7°C, and
  - iii) a heat transfer fluid return temperature of 13°C (see Note A-8.4.4.9.(2)(c), 8.4.4.10.(2)(d) and 8.4.4.11.(4)(b)), and
- e) the peak pumping power demand shall be identical to the sum of the peak pumping power demands used for the proposed *building's* cooling loop (see Note A-8.4.4.9.(2)(d), 8.4.4.10.(2)(e) and 8.4.4.11.(4)(c)).

**Table 8.4.4.10.**  
**Number and Type of Chillers**  
Forming Part of Sentence 8.4.4.10.(2)

Total Cooling Capacity	Number	Type
≤ 352 kW	1	Reciprocating, water-cooled
> 352 kW and ≤ 1055 kW	1	Scroll, water-cooled
> 1055 kW and ≤ 2110 kW	2, of equal cooling capacity	Scroll, water cooled
> 2110 kW	2 or more, of equal cooling capacity; the cooling capacity of each chiller shall be not more than 2813 kW	Centrifugal, water-cooled

**3)** Where the cooling system of the proposed *building* is a direct-expansion system, the reference *building's* cooling system shall be a direct-expansion system and that system shall be modeled as follows:

- a) where the cooling capacity of the system is not more than 66 kW, the system shall be modeled as a two-stage system of equal capacity, and
- b) where the cooling capacity is more than 66 kW, the system shall be modeled as a system whose number of stages is equal to its capacity divided by 66 kW, then rounded to the next whole number.”.

8.4.4.11.	<p>Strike out “Where applicable,” in Sentence (1);</p> <hr/> <p>Replace Sentences (4) to (7) by the following:</p> <p>“<b>4)</b> The cooling tower pumping system shall be modeled</p> <p>a) as a constant-speed system,</p> <p>b) with a flow rate sized using the following parameters:</p> <p>i) the cooling tower’s capacity, and</p> <p>ii) a rise of the heat transfer fluid temperature of 6°C (see Note A-8.4.4.9.(2)(c), 8.4.4.10.(2)(d) and 8.4.4.11.(4)(b)), and</p> <p>c) with a peak pumping power demand identical to the sum of the peak pumping power demands used for the proposed <i>building</i> loop (see Note A-8.4.4.9.(2)(d), 8.4.4.10.(2)(e) and 8.4.4.11.(4)(c)).</p> <p><b>5)</b> The fan of each cooling tower cell shall be modeled as a constant-speed axial fan</p> <p>a) with a stop-start control that maintains the tower outlet water temperature at 29°C, and</p> <p>b) whose motor has a rated capacity equal to 1.5% of the cell cooling capacity, in kW.”.</p>
8.4.4.12.	Strike out the Article.
8.4.4.13.	Strike out the Article.
8.4.4.14.	<p>Replace the Article by the following:</p> <p>“<b>8.4.4.14. Pumps</b></p> <p><b>1)</b> Except as provided in Sentences 8.4.4.9.(2), 8.4.4.10.(2), 8.4.4.11.(4) and 8.4.4.20.(4), pumps shall be modeled in the reference <i>building</i> so that, for each pump, the ratio between the peak power demand and the peak pumping flow is identical to that of the proposed <i>building</i>’s corresponding pump.</p> <p><b>2)</b> Where the pumping system is a variable-flow system, the pumps referred to in Sentence (1) shall be modeled in accordance with Article 8.4.5.10. as</p> <p>a) pumps that ride their performance curve, or</p> <p>b) pumps with variable speed drive, where the pumping system is referred to in Clause 5.2.6.1.(1)(a).”.</p>
8.4.4.15.	<p>Replace Sentence (2) by the following:</p> <p>“<b>2)</b> It is permitted to consider that the outdoor airflow of a <i>temperature-control zone</i> of the reference <i>building</i> is the outdoor airflow of the same <i>temperature-control zone</i> of the proposed <i>building</i> multiplied by 1.2</p>

	<ul style="list-style-type: none"> <li>a) where the distribution air of the proposed <i>building</i> is circulated <ul style="list-style-type: none"> <li>i) near the floor;</li> <li>ii) at a temperature less than that of the <i>temperature-control zone</i>,</li> <li>iii) unidirectionally, and</li> <li>iv) at low velocity, and</li> </ul> </li> <li>b) where the return air of the proposed <i>building</i> is captured near the ceilings.”.</li> </ul>
8.4.4.16.	Strike out the Article.
8.4.4.17.	<p>Replace the Article by the following:</p> <p><b>“8.4.4.17. Fans</b></p> <p>1) Where the HVAC system of a <i>thermal block</i> of the proposed <i>building</i> includes a fan that exhausts air directly to the outside and meets the requirements of Sentences 5.2.3.1.(3) or 5.2.10.1.(3), its flow rate, power demand, operating schedule and part-load performance shall be modeled identically in the reference <i>building</i>.</p> <p>2) Constant-volume fans shall be modeled as airfoils without inlet vanes riding their performance curves, in accordance with Article 8.4.5.11.</p> <p>3) Variable-volume fans shall be modeled as forward curves with inlet vanes, in accordance with Article 8.4.5.11.</p> <p>4) The terminal zone boxes without fan of a variable-flow HVAC system shall be modeled taking into consideration a minimum flow as being the greater of</p> <ul style="list-style-type: none"> <li>a) 30% of the peak flow of the <i>temperature-control zone</i>, or</li> <li>b) the outdoor airflow required for acceptable indoor air quality in the <i>temperature-control zone</i> as prescribed by the NBC.</li> </ul> <p>5) The terminal zone boxes with fan of a variable-flow HVAC system shall be modeled as having</p> <ul style="list-style-type: none"> <li>a) a minimum flow equal to the outdoor airflow required for acceptable indoor air quality in the <i>temperature-control zone</i> as prescribed by the NBC, and</li> <li>b) a parallel fan <ul style="list-style-type: none"> <li>i) whose maximum flow is set at 50% of the peak flow of the <i>temperature-control zone</i>, and</li> <li>ii) whose ratio between the peak power demand and the flow is 0.74 W/(L/s).</li> </ul> </li> </ul> <p>6) Return or relief fans shall be modeled with a peak flow as being the greater of</p> <ul style="list-style-type: none"> <li>a) the supply fan peak flow less the outdoor airflow rate, and</li> <li>b) 90% of the supply fan peak flow.”. </li></ul>
8.4.4.18.	<p>Replace the Article by the following:</p> <p><b>“8.4.4.18. Air Supply System</b></p>

	<p>1) The supply airflow rate provided by HVAC systems shall be modeled as being equal to the sum of the airflow rates supplied to each <i>temperature-control zones</i> calculated in accordance with Sentence (2).</p> <p>2) The supply airflow rate to a <i>temperature-control zone</i> shall be modeled as being the greatest of</p> <ol style="list-style-type: none"> <li>the airflow rate for heating, based on the peak heating load and a temperature difference of 21°C,</li> <li>the airflow rate for cooling, based on the peak cooling load and a temperature difference of 11°C, or</li> <li>the outdoor air ventilation rate supplied to the <i>temperature-control zone</i>, in accordance with Article 8.4.4.15.</li> </ol> <p>3) Where a fan of the proposed <i>building</i> is part of an HVAC system whose total fan power ratings is at least 4 kW, the static pressure of the reference <i>building's</i> corresponding fan is permitted to be adjusted using the following equation:</p> $P_{\text{Ref adjusted}} = P_{\text{Ref}} + \sum_{i=1}^n \frac{\text{SPA}_i \times D_{i,\text{Prop}}}{D_{vi,\text{Prop}}}$ <p>where</p> <p><math>P_{\text{Ref adjusted}}</math> = adjusted pressure of the fan in the reference <i>building</i>, in Pa,</p> <p><math>P_{\text{Ref}}</math> = pressure of the fan in the reference <i>building</i> as established in Tables 8.4.4.7.-B to 8.4.4.7.-E, in Pa,</p> <p><math>\text{SPA}_i</math> = static pressure adjustment due to the <math>i^{\text{th}}</math> equipment as established in Table 5.2.3.1., in Pa,</p> <p><math>n</math> = number of equipment requiring static pressure adjustment,</p> <p><math>D_{i,\text{Prop}}</math> = flow through the <math>i^{\text{th}}</math> equipment of the proposed <i>building</i>, in L/s, and</p> <p><math>D_{vi,\text{Prop}}</math> = design flow rate of fan serving the <math>i^{\text{th}}</math> equipment of the proposed <i>building</i>, in L/s.”.</p>
8.4.4.19.	<p>Replace Sentences (1) to (3) by the following:</p> <p>“1) Where the proposed <i>building's</i> HVAC system must be equipped with heat- or energy-recovery equipment under Sentence 5.2.10.1.(1), that equipment shall be modeled in the reference <i>building</i> to the following conditions:</p> <ol style="list-style-type: none"> <li>the static pressures of fans shall be adjusted according to Sentence 8.4.4.18.(3), and</li> <li>the heat-recovery efficiency shall be <ol style="list-style-type: none"> <li>60%, or</li> <li>65% for <i>dwelling units</i> located in a municipality whose number of heating degree-days under 18°C is 6000 or more.</li> </ol> </li> </ol> <p>2) Where the proposed <i>building</i> has refrigeration systems referred to in Article 5.2.10.3., the reference <i>building's</i> refrigeration system shall be modeled to the following conditions:</p>

	<p>a) the operating and performance characteristics, capacity, part-load performance and pumping flows shall be identical to those of the proposed <i>building's</i> refrigeration system,</p> <p>b) peak load and demand schedules shall be identical to those of the proposed <i>building</i>,</p> <p>c) the heat-recovery equipment shall have</p> <p style="padding-left: 20px;">i) the capacity to reject recovered heat to the hydronic heating systems, and</p> <p style="padding-left: 20px;">ii) the same means to reject unrecovered heat as that of the proposed <i>building</i>, and</p> <p>d) the efficiency of the heat-recovery equipment shall be the smaller of the following values:</p> <p style="padding-left: 20px;">i) 25% of the recovery efficiency, or</p> <p style="padding-left: 20px;">ii) 80% of the space heating capacity and <i>service water</i> heating capacity.</p> <p>(See Note A-8.4.4.19.(2).)</p> <p><b>3)</b> Where the proposed <i>building</i> has a pool referred to in Sentence 5.2.10.2.(1), the dehumidification equipment referred to in Sentence 5.2.10.2.(3) serving that <i>temperature-control zone</i> shall be modeled in the reference <i>building</i> as an electric air-cooled chiller</p> <p>a) sized for the peak dehumidification load,</p> <p>b) to the conditions described in Sentence 8.4.4.10.(2),</p> <p>c) having a COP varying according to the load, and</p> <p>d) equipped with a heat-recovery unit compliant with Sentence 5.2.10.2.(2).”.</p>
8.4.4.20.	<p>Replace the article by the following:</p> <p><b>“8.4.4.20. Service Water Heating System</b></p> <p><b>1)</b> The reference <i>building's service water</i> heating system shall be modeled as being identical to that of the proposed <i>building</i> as regards the following characteristics:</p> <p>a) storage capacity, and</p> <p>b) power input.</p> <p><b>2)</b> Where the proposed <i>building's service water</i> heating system includes a storage tank, the <i>service water</i> setpoint temperature of the reference <i>building's</i> storage tank shall be identical to that of the proposed <i>building</i>.</p> <p><b>3)</b> Where the proposed <i>building's service water</i> heating system comprises multiple water heaters, the reference <i>building's service water</i> heating system shall be modeled with the same number of water heaters.</p> <p><b>4)</b> Where the proposed <i>building's service water</i> heating system is a recirculation system, the reference <i>building's</i> circulation pumps shall be modeled as a single pump with</p> <p>a) constant speed operation, and</p> <p>b) a total flow rate and pumping power, in W/(L/s), that are identical to that of the proposed <i>building's</i> circulation pumps.”.</p>



	<p>Add the following Article:</p> <p><b>“8.4.4.21. Energy Recovered on Site and Renewable Energy Produced on Site</b></p> <p><b>1)</b> Except as provided in Sentence (2), where the proposed <i>building</i> uses energy recovered on site or renewable energy produced on site to serve an HVAC system or a <i>service water</i> heating system, the corresponding HVAC system or <i>service water</i> heating system modeled in the reference <i>building</i> shall</p> <p>a) be the same type as the proposed <i>building’s</i> system,</p> <p>b) use the same primary supply energy source as the system used in the proposed <i>building</i>, and</p> <p>c) be sized to fully meet the load.</p> <p><b>2)</b> Where no supply energy source is used in the proposed <i>building</i>, the reference <i>building</i> shall consist of</p> <p>a) an electric resistance sized for the peak heating load, where the energy recovered on site or the renewable energy produced on site is used for heating purposes, or</p> <p>b) an electric air-cooled chiller sized for the peak cooling load, where the energy recovered on site or the renewable energy produced on site is used for cooling purposes.</p> <p><b>3)</b> Where the energy recovered on site or the renewable energy produced on site is electricity, that electricity shall not be accounted for in modeling the reference <i>building</i>.”.</p>
8.4.5.1.	<p>Replace Sentence (1) by the following:</p> <p><b>“1)</b> In the absence of equivalent functionalities of programs modeling the part-load operation of HVAC system’s equipment or <i>service water</i> heating systems, the part-load performance curves for the same reference <i>building’s</i> equipment shall be calculated in accordance with this Subsection. (See Note A-8.4.5.1.(1).)”.</p>
	<p>Add the following Articles:</p> <p><b>“8.4.5.10. Pumps</b></p> <p><b>1)</b> The power draw of pumps at part-load, <math>P_{\text{partload}}</math>, in kW, of the reference <i>building</i> shall be calculated</p> <p>a) using the following formula, where the flow ratio at part-load conditions, <math>V_{\text{partload}}</math>, in L/s, to the flow rate at rated conditions, <math>V_{\text{rated}}</math>, in L/s, is less than the capacity coefficient taken from Table 8.4.4.10.:</p> $P_{\text{partload}} = P_{\text{rated}} \times e$ <p>where</p> <p><math>P_{\text{rated}}</math> = power draw at rated conditions, in kW, and</p> <p><math>e</math> = applicable capacity coefficient taken from Table 8.4.4.10., or</p>

- b) using the following formula, where the flow ratio at part-load conditions,  $V_{partload}$ , in L/s, to the flow rate at rated conditions,  $V_{rated}$ , in L/s, is not less than the capacity coefficient taken from Table 8.4.4.10.:

$$P_{partload} = \left\{ P_{rated} \times \left[ a + \left( b \times \frac{V_{partload}}{V_{rated}} \right) \right] \right\} + \left[ c \times \left( \frac{V_{partload}}{V_{rated}} \right)^2 \right]$$

where

$P_{rated}$  = power draw at rated conditions, in kW, and

a, b and c = applicable capacity coefficients taken from Table 8.4.5.10.

**Table 8.4.5.10.**  
Capacity Coefficients Used in the Calculation of  $P_{partload}$   
Forming Part of Sentence 8.4.5.10.(1)

Type of Pump	Coefficients for Calculation of $P_{partload}$				
	a	b	c	d	e
Pump riding its curve	0.227143	1.178929	-0.41071	0.47	0.68
Pump with variable speed drive	0.00153028	0.00520806	1.0086242	0.2	0.04

#### 8.4.5.11. Fans

- 1) The divided power ratio, P, to flow ratio, F, of the fans of the reference *building* at part-load shall be obtained

- a) using the following formula, where the ratio of output capacity to rated power, P, is less than the capacity coefficient taken from Table 8.4.5.11.:

$$F = e$$

where

F = ratio of outlet flow to rated flow, and

e = applicable capacity coefficient taken from Table 8.4.5.11., or

- b) using the following formula, where the ratio of output capacity to rated power, P, is not less than the capacity coefficient taken from Table 8.4.5.11.:

$$F = a + (b \times P) + (c \times P^2)$$

where

P = ratio of output capacity to rated power,

F = ratio of outlet flow to rated flow, and

a, b and c = applicable capacity coefficients taken from Table 8.4.5.11.

**Table 8.4.5.11.**  
Capacity Coefficients Used in the Calculation of P/F  
Forming Part of Sentence 8.4.5.11.(1)

Type of Fan	Coefficients
-------------	--------------

	a	b	c	d	e
Airfoil without inlet vane riding its performance curve	0.227143	1.178929	-0.41071	0.47	0.68
Backward inclined fan without inlet vane riding its performance curve					
Airfoil with inlet vanes	0.584345	-0.57917	0.970238	0.35	0.50
Backward inclined fan with inlet vanes					
Forward curved fan with inlet vanes	0.339619	-0.84814	1.495671	0.25	0.22
Variable speed drive	0.00153028	0.00520806	1.0086242	0.20	0.04
”.					
<b>8.5.1.1.</b>	<p>Replace respectively, in numerical order, the headings, objectives and functional statements of the Articles concerned below by the following in Table 8.5.1.1:</p> <p><b>“8.4.2.9. Manually Operated Shading Devices</b>  (1) [F99-OE1.1]”;</p> <p><b>“8.4.3.2. Operating Schedules</b>  (1) [F99-OE1.1]”;</p> <p><b>“8.4.3.6. HVAC Systems</b>  (1) [F99-OE1.1]  (2) [F99-OE1.1]”;</p> <p><b>“8.4.3.7. Temperature-Control Zones</b>  (1) [F99-OE1.1]  (2) [F99-OE1.1]  (3) [F99-OE1.1]  (4) [F99-OE1.1]”;</p> <p><b>“8.4.3.8. Internal and Service Water Heating Loads</b>  (1) [F99-OE1.1]”;</p> <p><b>“8.4.3.9. Energy Recovered on Site and Renewable Energy Produced on Site</b>  (1) [F99-OE1.1]  (2) [F99-OE1.1]</p>				

(3) [F99-OE1.1]”;

**“8.4.4.6. HVAC Systems and Service Water Heating Systems**

(1) [F99-OE1.1]

(2) [F99-OE1.1]

(3) [F99-OE1.1]

(4) [F99-OE1.1]

(5) [F99-OE1.1]

(6) [F99-OE1.1]

(7) [F99-OE1.1]

(8) [F99-OE1.1]

(9) [F99-OE1.1]”;

**“8.4.4.14. Pumps**

(1) [F99-OE1.1]

(2) [F99-OE1.1]”;

---

Replace the objectives and functional statements of the Articles concerned below by the following in Table 8.5.1.1:

**“8.4.3.1. General**

(2) [F99-OE1.1]”;

**“8.4.4.3. Building Envelope Components**

(1) [F99-OE1.1]

(2) [F99-OE1.1]

(3) [F99-OE1.1]

(4) [F99-OE1.1]”;

**“8.4.4.9. Heating System**

(1) [F99-OE1.1]

(2) [F99-OE1.1]

(3) [F99-OE1.1]

(4) [F99-OE1.1]”;

**“8.4.4.10. Cooling Systems**

(1) [F99-OE1.1]

(2) [F99-OE1.1]

(3) [F99-OE1.1]”;

---

Insert, in numerical order, the following objectives and functional statements in Table 8.5.1.1.:

**“8.4.2.2. Calculation Methods**

	<p>(5) [F99-OE1.1]  (6) [F99-OE1.1]  (7) [F99-OE1.1]”;</p> <p><b>“8.4.3.3. Building Envelope Components</b></p> <p>(4) [F99-OE1.1]  (5) [F99-OE1.1]  (6) [F99-OE1.1]  (7) [F99-OE1.1]  (8) [F99-OE1.1]”;</p> <p><b>“8.4.4.1. General</b></p> <p>(8) [F99-OE1.1]  (9) [F99-OE1.1]”;</p> <p><b>“8.4.4.7. HVAC System Selection</b></p> <p>(2) [F99-OE1.1]”;</p> <hr/> <p>Insert, in numerical order, the following Articles, objectives and functional statements in Table 8.5.1.1.:</p> <p><b>“8.4.4.21. Energy Recovered on Site and Renewable Energy Produced on Site</b></p> <p>(1) [F99-OE1.1]  (2) [F99-OE1.1]  (3) [F99-OE1.1]”;</p> <p><b>“8.4.5.10. Pumps</b></p> <p>(1) [F99-OE1.1]”;</p> <p><b>“8.4.5.11. Fans</b></p> <p>(1) [F99-OE1.1]”;</p> <hr/> <p>Strike out respectively the following objectives and functional statements in Table 8.5.1.1.:</p> <p><b>“8.4.1.2. Determination of Compliance</b></p> <p>(5) [F99-OE1.1]”;</p> <p><b>“8.4.2.8. Building Envelope</b></p> <p>(6) [F99-OE1.1]  (7) [F99-OE1.1]  (8) [F99-OE1.1]  (9) [F99-OE1.1]  (10) [F99-OE1.1]”;</p>
--	--

<p><b>“8.4.4.5. Lighting</b></p> <p>(4) [F99-OE1.1]  (5) [F99-OE1.1]  (6) [F99-OE1.1]  (7) [F99-OE1.1]  (8) [F99-OE1.1]  (9) [F99-OE1.1]  (10) [F99-OE1.1]  (11) [F99-OE1.1]  (12) [F99-OE1.1]”;</p> <p><b>“8.4.4.11. Cooling Tower Systems</b></p> <p>(6) [F99-OE1.1]  (7) [F99-OE1.1]”;</p> <p><b>“8.4.4.18. Supply Air Systems</b></p> <p>(4) [F99-OE1.1]  (5) [F99-OE1.1]  (6) [F99-OE1.1]”;</p> <p><b>“8.4.4.20. Service Water Heating Systems</b></p> <p>(5) [F99-OE1.1]  (6) [F99-OE1.1]  (7) [F99-OE1.1]  (8) [F99-OE1.1]  (9) [F99-OE1.1]”;</p> <hr/> <p>Strike out the following Articles, objectives and functional statements in Table 8.5.1.1.:</p> <p><b>“8.4.2.4. Thermal Mass</b></p> <p>(1) [F99-OE1.1]”;</p> <p><b>“8.4.2.5. Space Temperature</b></p> <p>(1) [F99-OE1.1]”;</p> <p><b>“8.4.2.7. Internal and Service Water Heating Loads</b></p> <p>(1) [F99-OE1.1]  (2) [F99-OE1.1]  (3) [F99-OE1.1]  (4) [F99-OE1.1]  (5) [F99-OE1.1]”;</p>
---

	<p><b>“8.4.4.2. Operating Schedules, Internal Loads, Service Water Heating Loads and Set-point Temperature</b></p> <p>(1) [F99-OE1.1]  (2) [F99-OE1.1]  (3) [F99-OE1.1]”;</p> <p><b>“8.4.4.8. Equipment Oversizing</b></p> <p>(1) [F99-OE1.1]  (2) [F99-OE1.1]”;</p> <p><b>“8.4.4.12. Cooling with Outside Air</b></p> <p>(1) [F99-OE1.1]”;</p> <p><b>“8.4.4.13. Heat Pumps</b></p> <p>(1) [F99-OE1.1]  (2) [F99-OE1.1]”;</p> <p><b>“8.4.4.16. Space Temperature Control</b></p> <p>(1) [F99-OE1.1]  (2) [F99-OE1.1]”.</p>
<p><b>Division B  Part 8  Schedule A</b></p>	
	<p>Add the following Notes:</p> <p><b>“A-8.1.1.2. Application.</b> The provisions of Sentence 8.1.1.2.(2) make compulsory compliance of electrical or mechanical systems with the relevant prescriptive requirements of Sections 4.2., 5.2., 6.2. and 7.2., and any other applicable provision in Section 8.4. where they are not defined in the plans and specifications. That means that, if at the time of assessment of compliance with the Code using this Part, the information on the systems is insufficient or incomplete, the prescriptive requirements must be applied. For the purposes of energy simulations, the system concerned of the reference building will have to be identical to that of the proposed building. Thus, the energy performance compliance path allows to consider only the energy performance of systems and components defined in the plans and specifications.</p> <p>Because the envelope has a very significant impact on energy consumption, the thermal and geometric characteristics of the envelope are essential to assess compliance of the building.</p> <p><b>A-8.4.1. Compliance.</b> The energy performance compliance path offers designers an alternative to the prescriptive requirements and trade-offs in Parts 3 to 7 of the Code. Those prescriptive requirements and trade-offs constitute compliance demonstration means relatively simple to apply, but offer less flexibility to designers</p>

	<p>who wish to design projects meeting the regulatory objectives without necessarily applying all the prescriptive requirements of the Code. For example, the energy performance compliance path allows the increase of the fenestration area of a building above the prescribed limit. In return, the designer may choose a heat-recovery unit with an efficiency greater than the minimum prescribed requirements that will make up for energy efficiency losses caused by the increase of the fenestration area. The objective is that the annual energy needs of the proposed building be lower than or equal to the annual energy needs of the reference building, determined according to the energy performance compliance path provided for in this Part.</p> <p>Contrary to the prescriptive requirements and trade-offs, the energy performance compliance path allows accounting the cross effects and interdependence of solutions implemented in the proposed building. For example, the importance of thermal gains of indoor lighting systems will have an impact on the sizing of the HVAC systems and their subsequent energy consumption. Similarly, the efficiency of a heating system will influence the choice of a designer to insulate more the building envelope in order to reach the annual energy needs of the reference building.</p> <p><b>A-8.4.1.2.(3) and (4) Determination of Compliance.</b> The sizing of the HVAC systems of a building have a significant impact on energy consumption. In practice, it may be justified, depending on circumstances, to oversize or undersize the HVAC systems of a project. To achieve equivalence in the comparison, the same sizing rules must apply to the reference building and the proposed building.</p> <p>To prevent unjustified transfer of “energy credits” caused by an abusive undersizing of the HVAC systems of the proposed building, the HVAC systems of the proposed and reference buildings must meet the same thermal comfort needs of the spaces served. To that end, the Code does not permit considering a proposed building whose thermal discomfort hours exceed those of the reference building or considering that the proposed and reference buildings have more than 300 h of heat discomfort in a simulated year.”.</p>
<b>A-8.4.1.4.</b>	Strike out the Note.
<b>A-8.4.1.4.(2)(b)</b>	<p>Replace the Note by the following:</p> <p><b>“A-8.4.1.4.(2)(b) Existing Equipment Characteristics.</b> Where the HVAC systems of the existing building serve the addition, the existing systems are modeled as they are, i.e. in accordance with the original plans and specifications, in accordance with the applicable regulatory requirements at the time of their installation or from on-site readings.”.</p>
	<p>Add the following Notes:</p> <p><b>“A-8.4.1.4.(3) Addition.</b> The party wall of the existing building will be modeled without heat gain or loss, unless the temperature difference between both sides of</p>



	<p>the wall is greater than 10°C, in which case heat exchanges between the addition and the existing building will be considered in the modeling.</p> <p><b>A-8.4.2. Compliance Calculation.</b> The maximum power demand of the electrical system and the annual energy consumption are evaluated by an energy modeling software, also called energy simulation software. The software includes at least one program, also called calculation engine. The software often includes graphic interfaces facilitating data entry and result analysis.</p> <p><b>A-8.4.2.2.(1) Major Program Deficiencies and Limitations.</b> The addenda of ANSI/ASHRAE 140, “Standard Method of Test for the Evaluation of Building Energy Analysis Computer Programs,” make it possible to verify whether a program has major deficiencies or limitations.”.</p>
A-8.4.2.2.(1)(g)	Strike out the Note.
	<p>Add the following Note:</p> <p><b>“A-8.4.2.2.(3) Internal Loads.</b> Normal internal loads include loads due to lighting, the presence of occupants, equipment directly used by occupants such as personal computers, automatic equipment such as computer servers, and other loads that do not consume energy such as food that must be kept in a freezer. Internal loads normally produce heat gains in the form of sensible heat, latent heat or radiant heat.</p> <p>Except for lighting, internal loads are not covered by the prescriptive paths of the Code. However, internal loads add cooling and/or heating loads to the building’s HVAC systems and service water heating systems. For that reason, internal loads representative of the building type or space function must be included in the compliance calculations. It will make it possible to correctly evaluate part-load performance of the HVAC systems and service water heating systems, and, by extension, the energy consumption of the proposed and reference buildings.</p> <p>Sentence 8.4.4.1.(4) provides that the internal loads must be modeled identically in the proposed and reference building energy models; only the energy consumed by the equipment and systems regulated by the Code can be modeled differently in the proposed and reference buildings.</p> <p>Tables A-8.4.3.8.(1)-A and A-8.4.3.8.(1)-B provide default values that are generally representative of the internal loads based on building or space type.</p> <p>It must be evaluated whether expected internal loads are correctly represented by the default values. Generally, if the default values provided in Tables A-8.4.3.8.(1)-A and A-8.4.3.8.(1)-B appear too small compared to the expected internal loads, some commercial and/or industrial operations and/or processes will not be correctly represented.</p> <p>The following loads, often associated to processes and/or activities, are examples of loads that are not represented in the default values in Tables A-8.4.3.8.(1)-A and A-8.4.3.8.(1)-B:</p>

	<ul style="list-style-type: none"> <li>• manufacturing machinery in an industrial building,</li> <li>• medical imaging equipment in a hospital,</li> <li>• computer servers in a data centre of an office building,</li> <li>• swimming pool water heating in a recreation centre,</li> <li>• cooking appliances and refrigeration equipment in a commercial kitchen or restaurant.</li> </ul> <p>HVAC systems of processes and/or activities that require temperatures, airflows or a humidity rate that do not correspond to the usual comfort conditions are excluded from the prescriptive path; there is no requirement for their operation or efficiency. In the performance path, those HVAC systems must be modeled because they have an impact on the cooling or humidification heating load of zones adjacent to the process.”.</p>
<b>A-8.4.2.7.(1)</b>	Strike out the Note.
	<p>Add the following Notes:</p> <p><b>“A-8.4.2.8. Modeling of Building Envelope Assemblies.</b> The programs generally permit modeling opaque building assemblies by a succession of materials in continuous layers. For example, a metal-frame wall construction could be modeled with three layers of materials representing the exterior cladding, the insulation and the interior finish. In order for the material assembly to have the value of the derated effective thermal resistance calculated in accordance with Sentence 8.4.2.8.(4), the thickness of the insulating layer will generally be adjusted by the program for each opaque building assembly of the proposed building having a different derated effective thermal resistance. Similarly, the thickness of the insulating layer will be adjusted by the program in the reference building to reach the value of the derated effective thermal resistance calculated from the values of the effective thermal resistance, the linear thermal transmittance and the point thermal transmittance required in Part 3.</p> <p><b>A-8.4.2.8.(4) Calculation of Effective Thermal Resistance.</b> Sentence 8.4.2.8.(4) requires that the effective thermal resistance of the envelope of the proposed building and the reference building be derated to consider heat losses. The penetrations and transitions of the proposed building shall be derated, whether or not they comply with the prescriptive requirements of Sentences 3.2.1.2.(1) to (7) and (10). Contrary to the trade-off path in Part 3, the compliant intersections of the proposed building shall be derated. The values of the compliant intersections of the proposed building shown in Tables 8.4.2.8.-A and 8.4.2.8.-B may be used. It is possible to use a value that better represents the intersections of the proposed building if that value was obtained in accordance with the requirements of Sentence 3.1.1.5.(7).</p> <p>The effective thermal resistance of opaque building assemblies of the reference building shall also be derated since that derating will have a different impact on the annual energy consumption of each of the buildings.</p>

	<p><b>A-8.4.2.8.(5) Derated Effective Thermal Resistance According to Temperature-control Zones.</b> In order to facilitate modeling, the derated effective thermal resistance may be considered for each opaque building assembly, independently of the adjacent temperature-control zones, where they are maintained at a temperature differential of not more than 10°C.</p> <p>For example, in an apartment building, if several sections of walls have been simplified to be considered as only one wall and that wall is in contact with eight temperature-control zones representing eight dwelling units, then the effective thermal resistance may be derated globally for that wall. Thus, a single value of the derated thermal resistance is entered in the energy modeling for the eight zones. That single value of the effective thermal resistance for that wall considers all the partial or complete penetrations of the envelope and the transitions between the different constructive systems of the envelope.</p> <p>However, in the case of a mixed-use building including a grocery store on the first floor having six temperature-control zones maintained at 21°C and two grocery storage zones maintained at 4°C, the effective thermal resistance is derated separately for the section of wall in contact with the first six zones and for the section of wall in contact with the other two zones.”.</p>
<b>A-8.4.2.9.(2)</b>	Strike out the Note.
	<p>Add the following Notes:</p> <p><b>“A-8.4.2.10.(3) Part-load Parameters.</b> The part-load of an HVAC system may vary in particular due to a change in climate conditions or in the fluid inlet temperature in the system.</p> <p><b>A-8.4.2.10.(4) Independent Modeling of an HVAC System’s Equipment Components.</b> Generally, the modeling of an HVAC system in a program requires to enter the individual efficiency rates of some components of the systems, such as supply fans, cooling compressors and condensers. However, energy or efficiency indexes of some HVAC equipment such as the EER (energy-efficiency ratio), may include, for example, the efficiency rate of a supply fan. The energy efficiency rate of the component must be isolated from the EER of the equipment and entered in the program. Consequently, the equipment efficiency, measured, for example, by the EER, must be adjusted to reflect the separate processing of the components before entering that value in the program. It is possible to calculate the adjusted EER or to obtain it by contacting the equipment manufacturer.”.</p>
<b>A-8.4.3.2.(1)</b>	<p>Replace the first Sentence of the Note by the following:</p> <p>“Operating schedules generally account for the following elements:</p> <ul style="list-style-type: none"> <li>• the presence of occupants,</li> <li>• the operation of interior lighting,</li> <li>• the operation of receptacle equipment,</li> <li>• the operation of HVAC systems,</li> </ul>

	<ul style="list-style-type: none"> <li>• the operation of service water systems.</li> </ul> <p>Tables A-8.4.3.2.(1)-A to A-8.4.3.2.(1)-K contain default values of operating schedules of building parameters for simulation purposes. Those schedules may be used with Table A-8.4.3.8.(1)-A or A-8.4.3.8.(1)-B if more accurate information is not available. If the building or space type is not listed in Table A-8.4.3.8.(1)-A or A-8.4.3.8.(1)-B, the schedule that most closely corresponds to the occupancy of the proposed building or space should be used.”.</p>
<b>A-8.4.3.2.(2)</b>	Strike out the Note.
<b>A-8.4.3.3.(2)</b>	<p>Replace the Note by the following:</p> <p><b>“A-8.4.3.3.(2) Energy Modeling of the Proposed Building Considering the Fenestration Shading Effects.</b> Where the modeler considers the effect of shading on fenestration, the existing surrounding elements that have an impact on the building must be considered in the modeling. For example, the potential energy gain due to the sun breaker system is partly cancelled where a neighbouring immovable or structure casts its shadow on the proposed building.</p> <p>The 10% reduction of sun gain and visible sun transmittance coefficients of the fenestration considers the darkening due to dirt and dust present on the fenestration.”.</p>
	<p>Add the following Notes:</p> <p><b>“A-8.4.3.3.(3)(a) Solar Heat Gain and Visible Sun Transmittance Coefficients of Fenestration.</b> The 20% reduction of solar heat gain and visible sun transmittance coefficients of the fenestration is explained by the darkening effect set at 10% due to dirt and dust on the fenestration and by the darkening effect set at 10% due to surrounding elements, the building itself and the permanent automated shading devices. Those adjusted coefficients allow the modeler to not model the shading in the program as provided in Sentence 8.4.3.3.(2).</p> <p><b>A-8.4.3.3.(4) Air Leakage Rate of the Building Envelope.</b> The air leakage rate of 0.25 L/(s·m<sup>2</sup>), which is a typical infiltration rate at 5 Pa, is used in the energy consumption model and may not reflect the real value encountered under operating conditions. That rate is based on pressure differentials typically encountered under operating conditions.</p> <p><b>A-8.4.3.3.(7) Modeling of Building Assemblies in Contact with the Ground.</b> The detailed calculation of the annual heat transfer of building assemblies in contact with the ground is complex and may require a significant investment of time. Indeed, the heat transfer with the ground varies in particular based on the geometry of the building, the depth of the foundations, the climate zone, and the arrangement of the materials composing the opaque building assemblies in contact with the ground. In addition, thermal conductivity of the ground, the most important parameter for quantifying the heat transfer with the ground, varies significantly based on several factors such as ground humidity rate, type of ground, ground temperature and</p>

	<p>ground density. The effect of frost, snow cover and depth of the groundwater may also have an influence on heat transfer.</p> <p>The calculation of heat transfer of the building assemblies in contact with the ground is treated in different manners in programs. Some programs implement detailed calculation methods while others use simplified methods to estimate the annual heat transfer of opaque building assemblies in contact with the ground. The purpose of Sentence 8.4.3.3.(7) is to prohibit performance exchanges with building assemblies in contact with the ground where simplified methods for calculating heat transfer with the ground are used by the program. Although simplified methods generally allow the definition of the properties of the insulation under the slab and those at the foundation wall level, those methods are not sufficiently accurate to quantify heat transfer with the ground. Such simplified methods are described in the “ASHRAE Handbook – Fundamentals”. Another example of a simplified method, defined from regression analyses and used in some programs, takes into account factors representing heat transfer through the floor and walls (factors F and C).</p> <p>For performance exchanges of building assemblies in contact with the ground to be considered in the performance path, Sentence 8.4.3.3.(7) requires that the program be capable to accurately represent the arrangement of the insulation and the properties of the building assemblies in contact with the ground such as dimensions, specific heat, density and thermal conductivity.</p> <p>Before considering modeling performance exchanges of building assemblies in contact with the ground, compliance of the calculation method used with Sentence 8.4.3.3.(7) must be verified. If it does not, as specified in Article 3.4.1.2., the prescriptive requirements of Subsection 3.2.3. apply to building assemblies in contact with the ground of the proposed building. In accordance with Clause 8.4.4.1.(4)(i), those assemblies will be modeled in the same manner as the reference building.</p> <p><b>A-8.4.3.4.(2) Occupancy Control Factors.</b> As provided in Sentence 4.4.1.2.(2), the interior lighting controls in Subsection 4.2.2. are mandatory and cannot be exchanged. That means that the controls must be present in the plans and specifications and must be modeled in the same manner for both the proposed and reference buildings. It concerns in particular controls in Table 4.2.1.6., listed in the columns under “Type of Lighting Control”.</p> <p>Contrary to the occupancy control factors, personal control factors and photocontrol factors may reduce the power of the installed lighting power of the proposed building but will not reduce the interior lighting power of the reference building.”.</p>
<b>A-8.4.3.4.(4)</b>	Replace “See Table A-8.4.3.2.(2)-B” by “See Tables A-8.4.3.8.(1)-A and A-8.4.3.8.(1)-B”.
<b>A-8.4.3.6.(1)</b>	<p>Replace the Note by the following:</p> <p><b>“A-8.4.3.6.(1) HVAC System.</b> The basic ventilation rates for the proposed building must be set to the minimum rates required by the applicable standards. The increase or reduction of outdoor air ventilation and exhaust rates are not means to comply with the energy performance compliance path.”.</p>

Add the following Notes:

**A-8.4.3.6.(2) Part-load HVAC System's Equipment Operation.** HVAC system's equipment rarely operates at full load. Consequently, the part-load efficiency must be adequately modeled. The designer must use available part-load performance curves of the proposed equipment, generally provided by the manufacturer, and must adapt those curves to the requirements of the programs. That adaptation is necessary since to model part-load equipment operation, each program includes its own mathematical models, generally in the form of a polynomial equation.

Where the program does not have the function of modeling the part-load operation of an HVAC system's equipment (for example, due to an atypical curve), Subsection 8.4.5. or the default curves of the programs may be used.

**A-8.4.3.7.(3) Temperature-control Zone Delimitation.** Where the temperature-control zones and HVAC systems are not entirely stated in the plans, modeling of those zones in accordance with the requirements of Sentence 8.4.3.7.(3) is necessary. Those requirements must be applied, for example, in the case of a commercial building whose layout of rental suites is unknown at the time of modeling.

**A-8.4.3.8.(1) Internal and Service Water Heating Loads and Illuminance Levels.** Tables A-8.4.3.8.(1)-A and A-8.4.3.8.(1)-B contain default values for internal and service water heating loads and their operating schedules for simulations purposes.

**Table A-8.4.3.8.(1)-A**  
Modeling Guidance for Loads, Operating Schedules and Illuminance Levels by Building Type

Building Type	Occupant Density, m <sup>2</sup> /occupant	Peak Receptacle Load, W/m <sup>2</sup>	Service Water Heating Load, W/occupant	Operating Schedule from Note A-8.4.3.2.(1)	Illuminance Levels, lx <sup>(1)</sup>
Automotive facility	20	5	90	E	400
Convention centre	8	2.5	30	C	300
Courthouse	15	5	60	A	400
Dining					
bar lounge/leisure	10	1	115	B	125
cafeteria/fast food	10	1	115	B	300
family	10	1	115	B	300
Dormitory	30	2.5	500	G	100
Exercise centre	10	1	90	B	350
Fire station	25	2.5	400	F	400
Gymnasium	10	1	90	B	500
Health care clinic	20	7.5	90	A	600
Hospital	20	7.5	90	H	350
Hotel/Motel	25	2.5	500	F	150
Library	20	2.5	90	C	500
Long-term care					
dwelling units	25	1.5	500	J	400
other	25	1.5	500	B	400
Manufacturing facility	30	10	90	A	450
Motion picture theatre	8	1	30	C	150
Multi-unit residential building	25	5	500	G	125
Museum	20	2.5	60	C	100
Office	25	7.5	90	A	400
Penitentiary	30	2.5	400	H	250
Performing arts theatre	8	1	30	C	250
Police station	25	7.5	90	H	400
Post office	25	7.5	90	A	400
Religious building	5	1	15	I	250

Retail area	30	2.5	40	C	450
School/University	8	5	60	D	400
Sports arena	10	1	90	B	400
Storage garage	1000	0	0	K	75
Town hall	25	7.5	90	D	400
Transportation facility	15	1	65	H	225
Warehouse	1500	1	300	A	150
Workshop	30	10	90	A	500

**Notes to Table A-8.4.3.8.(1)-A:**

- (1) The values are weighted averages that correspond to typical overall illuminance levels recommended for the buildings types listed and include both general lighting and task lighting. They are based on recommendations published by the IES.

**Table A-8.4.3.8.(1)-B**  
**Modeling Guidance for Loads, Operating Schedules and Illuminance Levels by Space Type**

Common Space Types					
Space Type	Occupant Density, m <sup>2</sup> /occupant	Peak Receptacle Load, W/m <sup>2</sup>	Service Water Heating Load, W/occupant	Operating Schedule <sup>(1)</sup> from Note A-8.4.3.2.(1)	Illuminance Levels (lx) <sup>(2)</sup>
Atrium (any height)	10	2.5	0	*	250
Audience seating area – permanent					
for auditorium	5	2.5	30	C	100
for convention centre	5	2.5	30	C	350
for gymnasium	5	0	30	B	350
for motion picture theatre	5	2.5	30	C	250
for penitentiary	5	2.5	30	C	250
for performing arts theatre	7.5	2.5	30	C	250
for religious building	5	1	15	I	150
for sports arena	5	0	30	B	150
other	5	1	15	*	100
Banking activity area and offices	25	5	60	A	400
Classroom/Lecture hall/Training room	7.5	5	65	D	400
Computer/Server room	100	200	90	* or H <sup>(3)</sup>	350
Conference/Meeting/Multi-purpose room	5	1	45	C	350
Confinement cell	25	0	325	G	400
Copy/Print room	100	60	90	A	400
Corridor/Transition area	100	0	0	*	150
Courtroom	5	2.5	30	A	400
Dining area					
for bar lounge/leisure dining	10	1	90	B	100
for cafeteria/fast food dining	10	1	120	B	200
for family dining	10	1	120	B	200
for penitentiary	10	1	120	B	200
for space designed to ANSI/IES RP-28, "Lighting and the Visual Environment for Senior Living" (and used primarily by residents)	10	1	120	B	200
other	10	1	120	B	200
Dressing/Fitting room for performing arts theatre	30	2.5	40	C	250
Electrical/Mechanical room	200	1	0	*	350
Emergency vehicle garage	25	2.5	325	H	350
Food preparation area	20	10	120	B	500
Guest room	25	2.5	600	F	200
Laboratory					
for classrooms	20	10	180	D	500
other	20	10	180	A	650
Laundry/Washing area	20	0	60	C	350

Loading dock – interior	500	0	0	H	200
Lobby					
for elevator	10	1	0	C	200
for hotel	10	2.5	30	H	250
for motion picture theatre	10	1	0	C	150
for performing arts theatre	10	1	0	C	200
for space designed to ANSI/IES RP-28, "Lighting and the Visual Environment for Senior Living" (and used primarily by residents)	10	2.5	30	B	150
Other	10	1	0	C	150
Locker room	10	2.5	0	*	100
Lounge/Break room					
for health care facility	10	1	60	B	150
other	10	1	60	B	150
Office	20	7.5	90	A	400
Pharmacy area	20	2.5	45	C	400
Sales area	30	2.5	40	C	500
Seating area - general	10	0	65	*	150
Stairway/Stairwell	200	0	0	*	150
Storage garage – interior	1000	0	0	K	75
Storage room					
≥ 5 m <sup>2</sup>	100	1	300	*	100
< 5 m <sup>2</sup>	100	0	0	*	100
Vehicle maintenance area	20	5	90	E	500
Washroom					
for space designed to ANSI/IES RP-28, "Lighting and the Visual Environment for Senior Living" (and used primarily by residents)	30	1	0	*	150
other	30	1	0	*	150
Workshop	30	10	90	A	500
<b>Building-Specific Space Types</b>					
Convention centre – exhibit space	10	2.5	30	C	500
Dormitory – living quarters	25	2.5	500	G	125
Dwelling unit	25	5	500	G	125
Fire station – living quarters	25	2.5	500	G	150
Gymnasium/Fitness centre					
exercise area	5	1	90	B	350
playing area	5	1.5	90	B	350
Health care facility					
exam/treatment room	20	10	90	C	600
imaging room	20	10	90	H	225
medical supply room	20	1	0	H	400
nursery	20	10	90	H	400
nurses' station	20	2.5	45	H	400
operating room	20	10	300	H	1000
patient room	20	10	90	H	400
physical therapy room	20	10	45	C	350
recovery room	20	10	180	H	250
Library					
reading area	20	1	90	C	500
stacks	20	0	90	C	500
Manufacturing facility					
detailed manufacturing area	30	10	90	A	600
equipment room	30	10	90	A	250
extra high bay area (> 15 m floor-to-ceiling height)	30	10	90	A	400
high bay area (7.5 m to 15 m floor-to-ceiling height)	30	10	90	A	400



	low bay area (< 7.5 m floor-to-ceiling height)	30	10	90	A	400
	Museum					
	general exhibition area	5	2.5	60	C	250
	restoration room	20	5	50	A	600
	Post office – sorting area	20	7.5	90	A	400
	Religious building					
	fellowship hall	5	1	45	C	250
	worship/pulpit/choir area	5	1	15	I	250
	Retail facility					
	dressing/fitting room	30	2.5	40	C	350
	mall concourse	20	1	30	C	400
	Space designed to ANSI/IES RP-28, "Lighting and the Visual Environment for Senior Living"					
	chapel (used primarily by residents)	10	1	15	I	150
	recreation room (used primarily by residents)	20	1	60	B	150
	Sports arena – playing area					
	playing area with facilities for more than 5000 spectators	5	1.5	90	B	1600
	playing area with facilities for more than 2000 spectators but not more than 5000 spectators	5	1.5	90	B	1000
	playing area with facilities for more than 200 spectators but not more than 2000 spectators	5	1.5	90	B	800
	playing area with facilities for less than 200 spectators or without a facility for spectators	5	1.5	90	B	500
	Transportation facility					
	airport concourse	20	0	65	H	150
	baggage/carousel area	20	2.5	65	H	250
	terminal ticket counter	10	2.5	65	H	250
	Warehouse – storage area					
	medium to bulky palletized items	100	1	65	A	200
	small hand-carried items <sup>(4)</sup>	50	1	65	A	300
	<b>Notes to Table A-8.4.3.8.(1)-B:</b>					
	(1) An asterisk (*) in this column indicates that there is no recommended default schedule for the space type listed. In general, such space types will be simulated using a schedule that is similar to the adjacent spaces served: e.g. a corridor space serving an adjacent office space will be simulated using a schedule that is similar to that of the office space.					
	(2) The values are weighted averages that correspond to typical overall illuminance levels recommended for the buildings/space types listed and include both general lighting and task lighting. They are based on recommendations published by the IES.					
	(3) A server room that serves a single building or a limited group of users would tend to have operating schedules matching those of that group or building. Server rooms that serve as data centres operating independently of the building in which they are located would tend to operate continuously.					
	(4) See Table A-4.2.1.6."					
<b>A-8.4.3.9.</b>	Strike out the Note.					

Add the following Notes:

**“A-8.4.3.9.(1) and (2) Energy Recovered on Site and Renewable Energy Produced on Site.** Sentence 8.4.3.9.(1) applies, for example, in the case of heat recovery from an exothermic process. Where heat-recovery technology is provided for in Subsection 5.2.10., the highest performance of the heat-recovery equipment planned in the proposed building is not permitted to be considered. In such a case, since that equipment must be modeled in the reference building under Article 8.4.4.19., the highest performance of that equipment in the proposed building will be considered by the program.

Sentence 8.4.3.9.(2) applies, for example, for the production of electricity by a photovoltaic panel.

**A-8.4.4.1.(2) Prescriptive Compliance.** The basic principle guiding the modeling of the reference building is that every component, device or system included in the building must comply with the applicable prescriptive requirements of Sections 3.2., 4.2., 5.2., 6.2. and 7.2. The requirements of Subsection 8.4.4. clarify the specific treatment of parameters some of which are not covered by the prescriptive requirements of the Code.

**A-8.4.4.1.(4) Building Characteristics.** The characteristics in Sentence 8.4.4.1.(4) are two-fold. Some characteristics of the building do not have specific prescriptive requirements but have considerable influence on energy consumption: the shape of the building, its orientation, receptacle loads, heat from a process, the consumption of an HVAC system dedicated only to a process, etc. The modeler cannot take into account those characteristics to improve the performance of the proposed building; they must be modeled identically in the proposed and reference buildings.

Other building characteristics, for example, the airtightness rate, have specific prescriptive requirements but their compliance is difficult to verify in the building once built. That is why the modeler is not permitted to use those characteristics to improve the performance of the proposed building. They must also be modeled identically in the proposed and the reference buildings.

Some indications to the contrary may be provided for in Subsections 8.4.3. and 8.4.4., in particular

- for Clause (4)(i), Sentence 8.4.4.3.(4) (see Note A-8.4.3.3.(7)),
- for Clause (4)(j), Sentence 8.4.4.4.(1), and
- for Clause (4)(x), Sentence 8.4.4.3.(2).

**A-8.4.4.1.(8) and (9) Equipment Energy Efficiency for Modeling the Reference Building.** The Energy Efficiency Act (S.C. 1992, c. 36) and its regulations fall under federal jurisdiction. The Act respecting energy efficiency and energy conservation standards for certain products (chapter N-1.01) and its regulations fall under Québec’s jurisdiction. They provide minimum levels for some types of equipment.

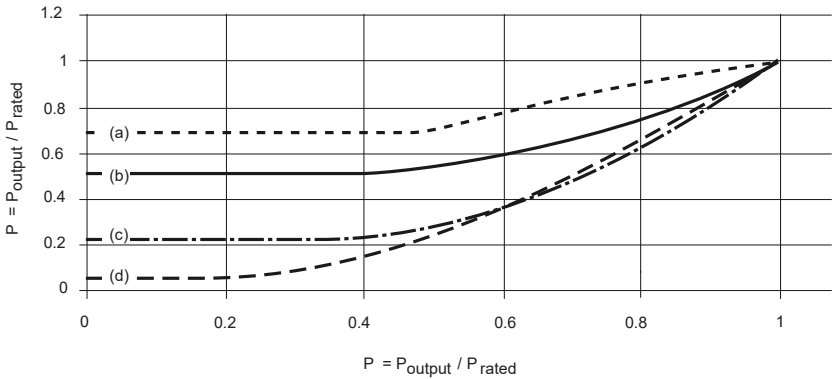
Where a minimum energy efficiency level for equipment is provided for in Québec legislation, Sentences 8.4.4.1.(8) and (9) provide for the use of that value for modeling the reference building.

	Where no minimum level is provided in Québec legislation, the energy efficiency of the equipment must be identical to that of the corresponding equipment in the proposed building, or that provided for in federal legislation.”.
<b>A-8.4.4.2.(1)</b>	Strike out the Note.
<b>A-8.4.4.2.(3)</b>	Strike out the Note.
	<p>Add the following Note:</p> <p><b>“A-8.4.4.3.(3) Energy Modeling of the Reference Building Considering Fenestration Shading Effects.</b> Where the modeler takes into consideration fenestration shading effects in the proposed building, the permanent and automated shading devices are not modeled in the reference building. However, as provided in Sentence 8.4.4.3.(3), shading effects due to surrounding elements and to the building itself must be modeled in the same manner as the proposed building.</p> <p>As provided in Sentence 8.4.2.9.(1), manually-operated interior shading devices, such as blinds, must not be modeled in neither the proposed building nor the reference building.”.</p>
<b>A-8.4.4.3.(8)</b>	Strike out the Note.
<b>A-8.4.4.4.(1)</b>	<p>Replace the Note by the following:</p> <p><b>“A-8.4.4.4.(1) Thermal Mass.</b> Sentence 8.4.4.4.(1) allows the modeling of the thermal mass of the reference building by specifying the thermal characteristics of a lightweight assembly rather than considering a thermal mass identical to that of the proposed building. Where the reference building is modeled with a thermal mass different from that of the proposed building, the parameters determining thermal inertia of the elements of the reference building envelope, such as specific heat and the density of a constructive layer, must be adjusted in accordance with that Sentence to reflect a lightweight construction having an overall weight of 55 kg/m<sup>2</sup> and a heat capacity of 50 kJ/(m<sup>2</sup>×°C).”.</p>
<b>A-8.4.4.5.(3)</b>	Strike out the Note.
<b>A-8.4.4.5.(6)</b>	Strike out the Note.
<b>A-8.4.4.5.(7)</b>	Strike out the Note.

<p><b>A-8.4.4.5.(10)(b)</b></p>	<p>Strike out the Note.</p>
<p><b>A-8.4.4.5.(11)</b></p>	<p>Strike out the Note.</p>
	<p>Add the following Notes:</p> <p><b>“A-8.4.4.6.(2) and (3) Types of Heat Pumps.</b> The following types of heat pumps are the most commonly used:</p> <p>Water-loop heat pump: a heat pump connected to an internal water loop used as a heat source and/or sink. The loop may include an auxiliary heat source (e.g. a boiler) and/or heat rejection device (e.g. a cooling tower).</p> <p>Water-source heat pump: a heat pump using as a heat source and/or sink</p> <ul style="list-style-type: none"> <li>• surface water (e.g. river, pond or lake),</li> <li>• groundwater,</li> <li>• a water loop directly carrying waste heat generated outside the building, or</li> <li>• a water loop indirectly carrying waste heat generated outside the building using a heat exchanger that separates the heat source and/or sink from an internal water loop.</li> </ul> <p>Ground-source heat pump: a heat pump using the ground as a heat source and/or sink through the use of a ground-heat exchanger in which circulates either a refrigerant supplied by the heat pump or a heat transfer fluid coming from an internal water loop.</p> <p>Air-source heat pump: a heat pump using the outside air as a heat source and/or sink.</p> <p><b>A-8.4.4.6.(4) Automatic Sizing of an HVAC System’s Equipment.</b> It is possible that, so as not to exceed the annual maximum number of discomfort hours provided for in Sentences 8.4.1.2.(3) and (4), the program requires oversizing or undersizing of the HVAC system’s equipment for modeling purposes.</p> <p>If an equipment of the proposed building is undersized or oversized in comparison to the calculated peak heating or cooling loads, the reference building’s corresponding equipment must be as well, according to the sizing factor of the proposed equipment. The sizing factor is calculated based on the procedure described in ASHRAE/IES 90.1, “User’s Manual”, and summarized here:</p> <ol style="list-style-type: none"> <li>1. the calculation engine calculates (ideal) peak loads for the proposed equipment,</li> <li>2. the sizing factor is obtained by dividing the capacity (or flow) of the proposed equipment (indicated in the plans and specifications) by the capacity (or flow) calculated in (1),</li> <li>3. the calculation engine calculates (ideal) peak loads for the corresponding equipment of the reference building, and lastly</li> </ol>

	<p>4. the sizing factor calculated in (2) is applied to the capacity (or flow) of the corresponding equipment of the reference building determined in (3).</p> <p><b>A-8.4.4.7.(2) and (3) Modeling of Air Distribution and Hydronic Loop Systems.</b> The requirements of Sentences 8.4.4.7.(2) and (3) do not aim to represent accurately the number of fans and individual pumps of a project but rather seek to match the distribution principles used for a temperature-control zone of the proposed building to those of the reference building corresponding zone.</p> <p><b>A-Table 8.4.4.7.-A HVAC System for the Proposed Building.</b> An example of the induction cooling system is an active chilled beam designed to recover ambient air from a room, cool it then return it to the room. Outdoor air, which comes in the chilled beam by the ventilation system, carries by induction the room ambient air that passes through a cooling coil.”.</p>
<b>A-8.4.4.8.</b>	Strike out the Note.
	<p>Add the following Notes:</p> <p><b>“A-8.4.4.9.(2)(c), 8.4.4.10.(2)(d) and 8.4.4.11.(4)(b) Pumping Flow.</b> Where the pumping flow rate, PFR, in L/min, is not calculated by the program, it may be evaluated using the following equation:</p> $PFR = \frac{P \times 60\,000}{C_p \times \rho \times \Delta T}$ <p>where</p> <ul style="list-style-type: none"> <li>P = power of the heating or cooling equipment, in kW,</li> <li>C<sub>p</sub> = specific heat of the heat transfer fluid, in kJ/(kg×K),</li> <li>ΔT = difference between the supply and return temperature of the heat transfer fluid, in °C, and</li> <li>ρ = density fo the heat transfer fluid, in kg/m<sup>3</sup>.</li> </ul> <p>The specific heat and the density vary based on the temperature and composition of the heat transfer fluid. Consequently, those two values will be different whether it is a hot or cool water loop, and will also vary based on the percentage of glycol in the heat transfer fluid. To take into account that reality, those values may be evaluated by considering the average temperature of the liquid circulating in the loop. For example, for a hot water loop with a supply at 82°C and a return at 54°C, the average will be 68°C. Water at a temperature of 68°C has a density of 978.87 kg/m<sup>3</sup> and a specific heat of 4.19 kJ/(kg×K).</p> <p><b>A-8.4.4.9.(2)(d), 8.4.4.10.(2)(e) and 8.4.4.11.(4)(c) Pumping Power Demand.</b> Where the pumping power demand, PPD, in W, is not defined by the program, it may be established using the following equation:</p> $PPD = \frac{PFR \times H \times \rho \times g}{60\,000 \times \eta}$

	<p>where</p> <p>PFR = pumping flow rate, in L/min (see Note A-8.4.4.9.(2)(c), 8.4.4.10.(2)(d) and 8.4.4.11.(4)(b)),</p> <p>H = loss of pressure in the system, in m of pressure head,</p> <p><math>\rho</math> = density of the liquid, in kg/m<sup>3</sup>,</p> <p>g = gravitational constant of 9.81 m/s<sup>2</sup>, and</p> <p><math>\eta</math> = combined efficiency turbine-motor-variable speed drive of pump.</p> <p>The reference building pump must have a power demand equivalent to the sum of the power demands of each hydronic loop pump of the proposed building.”.</p>
<b>A-8.4.4.13.</b>	Strike out the Note.
<b>A-8.4.4.13.(1)</b>	Strike out the Note.
<b>A-8.4.4.14.(2)</b>	Strike out the Note.
<b>A-8.4.4.17.(1)</b>	Strike out the Note.
<b>A-8.4.4.17.(2)</b>	Strike out the Note.
	<p>Add the following Note:</p> <p><b>“A-8.4.4.19.(2) Heat Recovery from Ice-making Machines.</b> A water-cooled, double-bundle water chiller having a load profile corresponding to the load planned on the ice-making machine is adequate for the purposes of Part 8 and allows the modeling of heat recovery.</p> <p>The following documents may be helpful in setting a more detailed model using refrigeration equipment rather than a water chiller and modeling the ice sheet itself and its interaction with adjacent components and spaces:</p> <ul style="list-style-type: none"> <li>• Zmeureanu, R., E.M. Zelaya and D. Giguère. (2002). Simulation de la consommation d'énergie d'un aréna à l'aide du logiciel DOE-2.IE. ESIm 2002 Conference, Montréal.</li> <li>• Ouzzane, M. et al. Cooling Load and Environmental Measurements in a Canadian Indoor Ice Rink. ASHRAE Transactions, Vol. 112, Pt. 2, Paper no. QC-06-008, pp. 538-545, 2006.</li> <li>• Sunyé, R. et al. ASHRAE Research Report 1289, Develop and Verify Methods For Determining Ice Sheet Cooling Loads, 2007.</li> </ul>

	<ul style="list-style-type: none"> <li>• Teysseidou, G., R. Zmeureanu, and D. Giguère. (2009). Thermal Response of the Concrete Slab of an Indoor Ice Rink. ASHRAE HVAC&amp;R Research, Vol. 15, No. 3, May 2009.</li> </ul> <p>Since ice-making for rinks and curling rinks is often associated with resurfacing activities, which require a significant amount of heated service water, the energy models of the proposed and reference buildings should account for the load in accordance with Clause 8.4.4.1.(4)(b).”.</p>
<p><b>A-8.4.4.20.(4)(a)</b></p>	<p>Strike out the Note.</p>
<p><b>A-8.4.4.20.(6)</b></p>	<p>Strike out the Note.</p>
<p><b>A-8.4.4.20.(7)</b></p>	<p>Strike out the Note.</p>
	<p>Add the following Note:</p> <p><b>“A-8.4.5.1.(1) Fan Part-Load Curves.</b> Figure A-8.4.5.1.(1) illustrates the equations for fan power versus flow rate as a graph.</p>  <p>(a) air foil or backward inclined riding fan curve without inlet vanes following its performance curve          (b) air foil or backward inclined with inlet vanes          (c) forward curved with inlet vanes          (d) variable speed drive</p> <p><b>Figure A-8.4.5.1.(1)</b>  <b>Fan part-load curves”.</b></p>

<b>Division B Climatic Data</b>	
<b>Table C-1</b>	Strike out the Note to Table C-1; <hr/> Strike out the column "Degree-Days Below 15°C" in Table C.
<b>Division B Part 10</b>	Strike out the Part.
<b>Division C Part 2</b>	
<b>2.2.1.1.</b>	Strike out Sentence (2).
<b>2.2.2.1.</b>	Replace Sentences (1) and (2) by the following: "1) The information available for verification purposes shall be provided to show that the proposed work will conform to this Code and indicate the compliance paths that were used. 2) Plans shall be drawn to scale and shall indicate the nature and extent of the work and proposed function in sufficient detail to establish that, when completed, the work and the proposed function will conform to this Code."
<b>2.2.2.2.</b>	Replace "inspection upon request" in Sentence (1) by "verification".
<b>2.2.2.3.</b>	Replace the portion before Clause (1)(a) in Sentence (1) by the following: "1) The following documentation on the <i>building envelope</i> shall be provided for verification purposes:"; <hr/> Replace Clauses (1)(b) and (1)(c) by the following: "b) total <i>fenestration</i> and door area excluding <i>skylights</i> , c) total automatic sliding door, revolving door and fire shutter area,"; <hr/>



	<p>Replace Clauses (1)(h) to (1)(m) by the following:</p> <ul style="list-style-type: none"> <li>“h) ratio of total <i>fenestration</i> and door area excluding <i>skylights</i> to gross wall area,</li> <li>i) the <i>effective thermal resistance</i> of building assemblies other than <i>fenestration</i> and doors, and the calculation method used to determine the <i>effective thermal resistance</i>,</li> <li>j) <i>overall thermal transmittance</i> of <ul style="list-style-type: none"> <li>i) <i>fenestration</i>,</li> <li>ii) doors with or without glazing forming part of the <i>building envelope</i>, and</li> <li>iii) access hatches,</li> </ul> </li> <li>k) description and location of <i>air barrier assemblies</i> in <i>opaque building assemblies</i>,</li> <li>l) details on the reduction of thermal bridging required in Article 3.2.1.2. of Division B,</li> <li>m) where Sentence 3.2.1.3.(1) of Division B applies, the indoor design temperature, and</li> <li>n) where Sentence 3.2.1.3.(2) of Division B applies, the heating setpoint in winter months.”;</li> </ul> <hr/> <p>Add the following Sentence:</p> <p>“<b>2)</b> Where Section 3.3. of Division B is applied, calculation details shall be provided for verification purposes and shall contain the information necessary to ensure compliance with the requirements of that Section.”.</p>
2.2.2.4.	<p>Replace the portion before Clause (1)(a) in Sentence (1) by the following:</p> <p>“<b>1)</b> The following documentation on the lighting systems shall be provided for verification purposes.”;</p> <hr/> <p>Strike out Clause (1)(b);</p> <hr/> <p>Replace Clauses (1)(c) to (1)(e) by the following:</p> <ul style="list-style-type: none"> <li>“c) method used to determine the <i>interior lighting power allowance</i> in each space assembly,</li> <li>d) where the <i>building area</i> method is used, for each space assembly, <ul style="list-style-type: none"> <li>i) the <i>floor surface area</i>, in m<sup>2</sup>,</li> <li>ii) the density of the <i>interior lighting power allowance</i>, in W/m<sup>2</sup>,</li> <li>iii) the <i>interior lighting power allowance</i>, in kW, and</li> <li>iv) the <i>installed interior lighting power</i>, in kW,</li> </ul> </li> <li>e) where the space-by-space method is used, for each space assembly, <ul style="list-style-type: none"> <li>i) the <i>floor surface area</i>, in m<sup>2</sup>, of each space,</li> <li>ii) the density of the <i>interior lighting power allowance</i>, in W/m<sup>2</sup>, of each space,</li> </ul> </li> </ul>

	<p>iii) the <i>interior lighting power allowance</i>, in kW, and iv) the <i>installed interior lighting power</i>, in kW.”;</p> <hr/> <p>Strike out Clause (1)(f);</p> <hr/> <p>Strike out “and justification for spaces exempted” in Clause (1)(g);</p> <hr/> <p>Replace Clauses (1)(h) and (1)(i) by the following: “h) adjustment and additional <i>interior lighting power</i> used, i) list of functions, spaces and/or equipment that are not included in the calculation of the <i>installed interior lighting power</i> and their controls, j) lighting zone used to determine <i>exterior lighting power allowances</i>, k) list of installed photocontrols and controlled indoor spaces, l) for each exterior application,     i) the <i>exterior lighting power allowance</i>, in kW, and     ii) the installed <i>exterior lighting power</i>, in kW, and m) installed exterior automatic controls.”;</p> <hr/> <p>Add the following Sentence: “2) Where Section 4.3. of Division B is applied, calculation details shall be provided for verification purposes and shall contain the information necessary to ensure compliance with the requirements of that Section.”.</p>
2.2.2.5.	<p>Replace Sentence (1) by the following: “1) The following documentation on the HVAC systems shall be provided for verification purposes: a) a description of each system, detailing its function, design details, performance characteristics and distribution arrangement, b) schematic and control diagrams and sequences of operation, c) start/stop and adjustment procedures, d) proposed temperature control devices in the spaces, e) details on heat-recovery equipment, if applicable, f) details on ice-making machines, if applicable, g) details on food refrigeration equipment, if applicable, h) details on commercial cooking equipment, if applicable, i) temperature setpoints of the spaces, j) thermal resistance of the installed duct and <i>plenum</i> insulation and that of piping insulation, and</p>

	k) limits of <i>temperature-control zones</i> , if applicable.”.
2.2.2.6.	<p>Replace the Article by the following:</p> <p><b>“2.2.2.6. Documentation on Service Water Heating Systems</b></p> <p>1) The following documentation on the <i>service water</i> heating shall be provided for verification purposes:</p> <p>a) a description of each system detailing its function, design details, performance characteristics and distribution arrangement,</p> <p>b) schematic and control diagrams and sequences of operation,</p> <p>c) start/stop and adjustment procedures, and</p> <p>d) thermal resistance of piping insulation.”.</p>
2.2.2.7.	<p>Replace the Article by the following:</p> <p><b>“2.2.2.7. Documentation on Transformers and Electric Motors</b></p> <p>1) Documentation on the performance characteristics of the transformers and electric motors in Part 7 shall be provided for verification purposes.”.</p>
2.2.2.8.	<p>Strike out Sentence (2);</p> <hr/> <p>Replace Clauses (3)(c) to (3)(e) by the following:</p> <p>“c) the lighting systems data summary section of the report shall contain the documentation required in Article 2.2.2.4. for both the proposed <i>building</i> and the reference <i>building</i> and, if daylight calculations are made, the calculation method and the results,</p> <p>d) the HVAC systems data summary section of the report shall contain the documentation required in Article 2.2.2.5. for the proposed <i>building</i> and the reference <i>building</i>,</p> <p>e) the <i>service water</i> heating data summary section of the report shall contain the documentation required in Article 2.2.2.6. for the proposed <i>building</i> and the reference <i>building</i>, and”;</p> <hr/> <p>Replace Subclauses (3)(f)(iv) and (3)(f)(v) by the following:</p> <p>“ iv) the <i>building energy target</i> of the reference <i>building</i> (sum of all energy sources), in MJ,</p> <p>v) a breakdown of energy usage, per energy source, for the following <i>building</i> components and systems: space-heating equipment, space-cooling equipment, <i>interior lighting</i>, <i>service water</i> heating equipment, elevators and escalators, fans, pumps and other HVAC equipment, miscellaneous equipment and receptacle power equipment, and</p> <p>vi) the maximum power demand of the electrical system determined during one year, from 1 December to 31 March inclusively, analyzed using time intervals</p>

	<p>no greater than 15 minutes unless the calculation engine only offers 60-minute intervals, for the proposed <i>building</i> and the reference <i>building</i>, in kW.”;</p> <hr/> <p>Replace Sentence (4) by the following:  <b>“4)</b> The climatic data and the modeling file of the proposed <i>building</i> and the reference <i>building</i> containing inputs for the programs shall be provided for verification purposes.”;</p> <hr/> <p>Replace Sentence (5) by the following:  <b>“5)</b> If the annual energy needs of the proposed <i>building</i> are not greater than those of the reference <i>building</i>, the report shall specify that the proposed <i>building</i> meets the requirements regarding annual energy needs, as described in Article 8.4.1.2. and in the NECB.”;</p> <hr/> <p>Replace Sentence (6) by the following:  <b>“6)</b> The report shall indicate that the analysis was performed in accordance with Part 8 of Division B of the NECB.”;</p> <hr/> <p>Add the following Sentences at the end of the Article:  <b>“10)</b> The report shall provide an explanation for each program error message and for each discrepancy between the results of the software and the range of values recommended in ANSI/ASHRAE 140, “Evaluation of Building Energy Analysis Computer Programs”.  <b>11)</b> The report shall specify any portion of energy that reduces the <i>annual energy consumption</i> of the proposed <i>building</i>, as a reduction due to renewable energy produced on site and/or a reduction due to energy recovered on site.  <b>12)</b> The report shall indicate the program(s) used.”.</p>
2.3.1.	<p>Replace the Subsection by the following:  <b>“2.3.1. Approval of Alternative Solutions</b>  <b>2.3.1.1. Conditions for Approval</b>  1) The proposed alternative solutions shall be approved by the Board on the conditions it sets pursuant to section 127 of the Building Act (chapter B-1.1).”.</p>
<b>Division C</b> <b>Schedule A</b> <b>Part 2</b>	Strike out the Notes.

3. The provisions of Chapter I.1 of the Construction Code (chapter B-1.1, r. 2), as they read before (*insert the date preceding the date of coming into force of this Regulation*), may apply to construction work referred to in sections 1.1.2 and 1.1.3 of the Construction Code, provided that the work begins before (*insert the date occurring 6 months after the date of coming into force of this Regulation*).

4. This Regulation comes into force on (*insert the date occurring 45 days after the date of publication of this Regulation in the Gazette officielle du Québec*).

106615

## Draft Regulation

Building Act  
(chapter B-1.1)

### Construction Code — Chapter III, Plumbing — Amendment

Notice is hereby given, in accordance with sections 10 and 11 of the Regulations Act (chapter R-18.1), that the Regulation to amend the Construction Code, appearing below, may be approved by the Government, with or without amendment, on the expiry of 45 days following this publication.

The draft Regulation amends Chapter III, Plumbing, of the Construction Code (chapter B-1.1, r. 2) in order to include by reference the National Plumbing Code of Canada 2020, with amendments to reflect the specific needs of Québec. The Regulation also extends most of the Québec amendments made to the previous edition.

This new regulation should not result in additional costs for construction work on plumbing systems.

Further information on the draft Regulation may be obtained by contacting Pierre-Yves Despatis, engineer, Régie du bâtiment du Québec, 255, boulevard Crémazie Est, bureau 100, Montréal (Québec) H2M 1L5; email: [projet.reglement@rbq.gouv.qc.ca](mailto:projet.reglement@rbq.gouv.qc.ca).

Any interested person having comments to make on the draft Regulation is asked to send them in writing, before the expiry of the 45-day period, to Caroline Hardy, Secretary General and Director of Institutional Affairs, Régie du bâtiment du Québec, 800, place D'Youville, 16<sup>e</sup> étage, Québec (Québec) G1R 5S3; email: [projet.reglement.commentaires@rbq.gouv.qc.ca](mailto:projet.reglement.commentaires@rbq.gouv.qc.ca).

MICHEL BEAUDOIN  
*President and Chief Executive Officer,*  
*Régie du bâtiment du Québec*

---