

“(3) the first semi-trailer has a maximum length of 16.20 m and a minimum length of 12 m, in the case of a B train double, or 13.50 m, in the case of an A or C train double, the whole without taking into account the presence of a flexible folding aerodynamic system located at the rear of the semi-trailer, provided that, as shown,

(a) any part of the system located at more than 1.9 m from the ground does not exceed, when unfolded, by more than 152 cm the rear end of the vehicle;

(b) any part of the system located at less than 1.9 m from the ground does not exceed, when unfolded, a virtual line connecting the following points:

i. a point located at 1.74 m from the ground and 121 cm from the rear end of the vehicle;

ii. a point located at the rear end and the lowest part of the vehicle bumper or, if there is no bumper, a point located at the lowest part of the rear end of the vehicle;

(c) any part of the system does not exceed, when folded, by more than 30.5 cm the rear end of the vehicle.

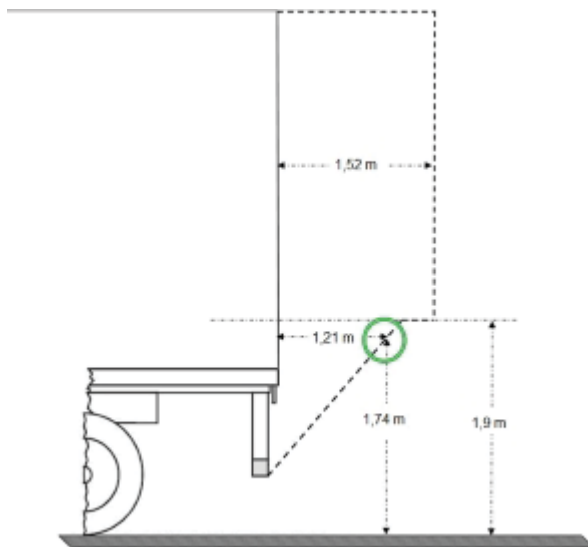

(4) the second semi-trailer has a maximum length of 16.20 m and a minimum length of 12 m, without taking into account the presence of a flexible folding aerodynamic system located at the rear of a road vehicle and complying with subparagraph 3;”

4. This Order comes into force on the fifteenth day following the date of its publication in the *Gazette officielle du Québec*. It is revoked on 10 October 2023.

Québec, 15 June 2021

FRANÇOIS BONNARDEL  
Minister of Transport

105119

## M.O., 2021

### Order number 2021-15 of the Minister of Transport dated 16 June 2021

Highway Safety Code  
(chapter C-24.2, s. 633.2)

Suspension of the requirement to equip with a flashing red warning light and an audible warning device a combination of road vehicles consisting of a tractor designed to draw farm equipment and that draws a trailer with a dump body

THE MINISTER OF TRANSPORT,

CONSIDERING the first paragraph of section 257.1 of the Highway Safety Code (chapter C-24.2), which provides that every heavy vehicle with a dump body whose height, when the dump body is raised, exceeds the maximum height prescribed by regulation must be equipped with a flashing red warning light and an audible warning device which must activate automatically when the dump body is not completely lowered;

CONSIDERING section 1 of the Regulation respecting dump body safety devices (chapter C-24.2, r. 9.2), which provides that the maximum height above which a heavy vehicle with a dump body must be equipped with the flashing red warning light and audible warning device provided for in section 257.1 of the Code, when the dump body is raised, is 4.15 m;

CONSIDERING section 633.2 of the Code, which provides that the Minister of Transport may, by order and after consultation with the Société de l'assurance automobile du Québec, suspend the application of a provision of the Code or the regulations for the period specified by the Minister if the Minister considers that it is in the interest of the public and is not likely to compromise highway safety;

CONSIDERING that section 633.2 of the Code provides that the publication requirement set out in section 8 of the Regulations Act (chapter R-18.1) does not apply to an order made under section 633.2;

CONSIDERING that trailers designed to draw farm equipment and that draw a trailer with a dump body are mainly used for the transportation of agricultural products or materials necessary for their production and they operate at reduced speed;

CONSIDERING that it is appropriate to suspend the application of the provisions of section 257.1 of the Highway Safety Code with respect to a combination of road vehicles having a total combined gross vehicle weight rating of 4,500 kg or more and consisting of a tractor, equipped with pneumatic tires or rubber caterpillar tracks, designed to draw farm equipment and that draws a trailer with a dump body;

CONSIDERING that the Minister of Transport considers that the measure is in the interest of the public and is not likely to compromise highway safety;

CONSIDERING that the Société de l'assurance automobile du Québec has been consulted;

ORDERS AS FOLLOWS:

1. The application of the provisions of section 257.1 of the Highway Safety Code (chapter C-24.2) with respect to a combination of road vehicles having a total combined gross vehicle weight rating of 4,500 kg or more and consisting of a tractor, equipped with pneumatic tires or rubber caterpillar tracks, designed to draw farm equipment and that draws a trailer with a dump body, is hereby suspended.

2. This Order comes into force on the fifteenth day following the date of its publication in the *Gazette officielle du Québec* and ceases to have effect on 1 July 2026.

Québec, 16 June 2021

FRANÇOIS BONNARDEL  
*Minister of Transport*

105121