

Regulations and other Acts

Gouvernement du Québec

O.C. 65-2021, 27 January 2021

Building Act
(chapter B-1.1)

Construction Code — Amendment

Regulation to amend the Construction Code

WHEREAS, under section 173 of the Building Act (chapter B-1.1), the Régie du bâtiment du Québec is to adopt by regulation a building code containing building standards in particular for buildings, facilities intended for use by the public, installations independent of a building or their vicinity;

WHEREAS, under section 176 of the Act, the code may require manufacturers to provide instructions regarding the assembly, erection, maintenance and inspection of materials, facilities and installations;

WHEREAS, under section 176.1 of the Act, the code may, with respect to the matters to which it applies, contain provisions concerning the subjects listed in section 185 of the Act;

WHEREAS, under section 178 of the Act, the code may require observance of a technical standard drawn up by another government or by an agency empowered to draw up such standards and provide that any reference it makes to other standards include subsequent amendments;

WHEREAS, under section 179 of the Act, the Board may determine the provisions of a code of which the infringement constitutes an offence under paragraph 7 of section 194 of the Act;

WHEREAS, under paragraph 0.1 of section 185 of the Act, the Board may, by regulation, exempt from the application of the Act or certain of its provisions categories of persons, contractors, owner-builders, manufacturers of pressure installations, or owners of buildings, facilities intended for use by the public, installations independent of a building or petroleum equipment installations, and categories of buildings, pressure installations, facilities, installations or construction work;

WHEREAS, under paragraph 0.2 of section 185 of the Act, the Board may, by regulation, for the purposes of section 10 of the Act, designate any facility as a facility intended for use by the public and establish criteria for determining whether or not a facility is intended for use by the public;

WHEREAS, under paragraph 3 of section 185 of the Act, the Board may, by regulation, determine the cases in which construction work must be reported to the Board, the time, form and manner according to which the report must be forwarded by the persons referred to in sections 22 and 37.2 of the Act and the conditions that they must fulfill;

WHEREAS, under paragraph 6.2 of section 185 of the Act, the Board may, by regulation, prohibit the sale, lease or exhibiting of materials or accessories which are not certified or approved for purposes of use in construction work on buildings, facilities intended for use by the public, installations independent of a building or petroleum equipment installations by a recognized person or body the Board designates;

WHEREAS, under paragraph 6.3 of section 185 of the Act, the Board may, by regulation, prohibit the sale, lease or exhibition of apparatus intended to be supplied from or to supply an electrical installation, used in a plumbing installation or petroleum equipment installation or intended to use gas, where the apparatus is not certified or approved by a recognized person or body the Board designates;

WHEREAS, under paragraph 7 of section 185 of the Act, the Board may, by regulation, determine the cases in which a contractor or owner-builder must obtain plans and specifications before construction work begins or final plans and specifications when the work is completed, in accordance with section 17.4 of the Act, and the other obligations, terms and conditions relating to those plans and specifications, in particular to their form, content, conservation and delivery;

WHEREAS, under paragraph 20 of section 185 of the Act, the Board may, by regulation, determine the cases in which it collects fees for approval, authorization, revision, inspection, training, consultation, issuance of certificates of conformity, accreditation of recognized persons or bodies, and verifications, and fix such fees;

WHEREAS, under paragraph 21 of section 185 of the Act, the Board may, by regulation, determine in particular an indicator of the importance of the activities or performance of a contractor which may be used as a basis for a levy, establish a fixed amount or an amount based on that indicator or both or all three, and determine the minimum and maximum of that indicator for a contractor to be subject to the levy;

WHEREAS, under paragraph 24 of section 185 of the Act, the Board may, by regulation, prescribe, for the purposes of paragraphs 21 and 22 of the section, in particular the form and content of the report to be forwarded by a contractor as well as the time limit within which it must be forwarded;

WHEREAS, under paragraph 36 of section 185 of the Act, the Board may, by regulation, set in particular the time limit and the manner of payment of the levy payable by each contractor;

WHEREAS, under paragraph 37 of section 185 of the Act, the Board may, by regulation, determine the provisions of a regulation adopted under the section of which the infringement constitutes an offence under paragraph 7 of section 194 of the Act, with the exception of provisions adopted under paragraphs 5.2, 18, 18.1, 20 and 36.1 and under paragraphs 16 and 17 with respect to fees payable;

WHEREAS, under paragraph 38 of section 185 of the Act, the Board may, by regulation, adopt, generally, any other related or suppletory provision it considered necessary to give effect to the provisions of the section and of the Act;

WHEREAS, under the first paragraph of section 192 of the Act, the contents of the codes or regulations may vary according to the classes of persons, contractors, owner-builders, manufacturers of pressure installations, owners of buildings, facilities intended for use by the public, installations independent of a building or petroleum equipment installations, owners or operators of gas or petroleum product distribution undertakings and classes of buildings, pressure installations, facilities or installations to which the codes or regulations apply;

WHEREAS the Board adopted the Regulation to amend the Construction Code on 11 June 2020;

WHEREAS, in accordance with sections 10 and 11 of the Regulations Act (chapter R-18.1), a draft Regulation to amend the Construction Code was published in Part 2 of the *Gazette officielle du Québec* of 23 September 2020 with a notice that it could be approved by the Government, with or without amendment, on the expiry of 45 days following that publication;

WHEREAS, under section 189 of the Building Act, every code or regulation of the Board is subject to approval by the Government which may approve it with or without amendment;

WHEREAS it is expedient to approve the Regulation with amendments;

IT IS ORDERED, therefore, on the recommendation of the Minister of Municipal Affairs and Housing:

THAT the Regulation to amend the Construction Code, attached to this Order in Council, be approved.

YVES OUELLET,
Clerk of the Conseil exécutif

Regulation to amend the Construction Code

Building Act

(chapter B-1.1, ss. 173, 176, 176.1, 178, 179, 185, pars. 0.1, 0.2, 3, 6.2, 6.3, 7, 20, 21, 24, 36, 37 and 38, and s. 192).

1. The Construction Code (chapter B-1.1, r. 2) is amended by replacing Chapter III by the following:

“CHAPTER III PLUMBING

DIVISION I SCOPE

3.01. In this Chapter, unless the context indicates otherwise, “Code” means the “National Plumbing Code of Canada 2015” (NRCC 56193), published by the Canadian Commission on Building and Fire Codes, National Research Council of Canada, as well as all subsequent amendments that may be published by that organization.

That Code is incorporated by reference into this Chapter subject to the amendments provided for in sections 3.04 to 3.06.

Despite the foregoing, amendments to that edition published after 27 March 2021 apply to construction work on a plumbing system only from the last day of the sixth month following the publication of the French and English versions of those amendments. If those versions are not published at the same time, the 6-month period runs from the date of publication of the last version.

The third paragraph does not apply to errata, which take effect as soon as they are published by the Canadian Commission on Building and Fire Codes.

3.02. Subject to the amendments made by this Chapter, the Code applies to all construction work on a plumbing system in

- (1) a building to which the Building Act (chapter B-1.1) applies; or
- (2) a facility intended for use by the public that is a tent or exterior inflatable structure to which Chapter I of the Construction Code (chapter B-1.1, r. 2) applies and is used
 - (a) as residential occupancies or care, treatment or detention occupancies whose floor area is 100 m² or more, or
 - (b) as assembly occupancies or mercantile occupancies whose floor area is more than 150 m² or whose load capacity is more than 60 persons.

For the purposes of this section, the definitions of “plumbing system” and “building” are those provided for in the Code, as adopted by this Chapter. In addition, the definitions of the following terms are those provided for in the National Building Code, as adopted by Chapter I of the Construction Code: “tent”, “inflatable structure”, “residential occupancy”, “care occupancy”, “treatment occupancy”, “detention occupancy”, “floor area”, “assembly occupancy”, “mercantile occupancy”.

3.03. Unless otherwise provided for, a reference in this Chapter to a standard or code is a reference to that standard or code as adopted by the chapter of the Construction Code (chapter B-1.1, r. 2) or Safety Code (chapter B-1.1, r. 3) that refers to it.

DIVISION II

AMENDMENTS TO THE CODE

3.04. The Code is amended in Division A

(1) by replacing Article 1.1.1.1. by the following:

“1.1.1.1. Application of this Code

(1) The NPC applies to the construction work performed on a *plumbing system* in every *building* and facility intended for use by the public as provided in section 3.02 of Chapter III of the *Construction Code* made pursuant to the Building Act (chapter B-1.1).

(2) In accordance with the NBC, every *building* shall, except as provided in Sentence (3), have plumbing facilities.

(3) If a hot water system is required under the NBC, the facility shall provide an adequate hot water supply.”;

(2) by replacing Clause (b) of Sentence (1) in Article 1.2.1.1. by the following:

“(b) using alternative solutions that will achieve at least the minimum level of performance required by Division B in the areas defined by the objectives and functional statements attributed to the applicable acceptable solutions approved by the Régie du bâtiment in accordance with section 127 of the Building Act (chapter B-1.1) (see Note A-1.2.1.1.(1)(b).).”;

(3) in Sentence (1) of Article 1.4.1.2.,

(a) by inserting the following after the definition of “Combustible”:

“*Construction Code* means the Construction Code (chapter B-1.1, r. 2) made pursuant to the Building Act (chapter B-1.1).”;

(b) by inserting “, retention pit” after “sump” in the definition of “*Storm building drain*”;

(c) by replacing the definition of “*Potable*” by the following:

“*Potable* means water intended for human consumption.”;

(d) by replacing the definition of “*Public use*” by the following:

“*Public use* (as applying to the classification of plumbing fixtures) means fixtures installed in locations other than those designated as *private use*.”;

(4) by inserting “PE-RT.....high temperature polyethylene” after “PEX.....crosslinked polyethylene” in Sentence (1) of Article 1.4.2.1.;

(5) by replacing Figure A-1.4.1.2.(1)-L in note A-1.4.1.2.(1) by the following:

“

**Figure A-1.4.1.2.(1)-L
Plumbing System**

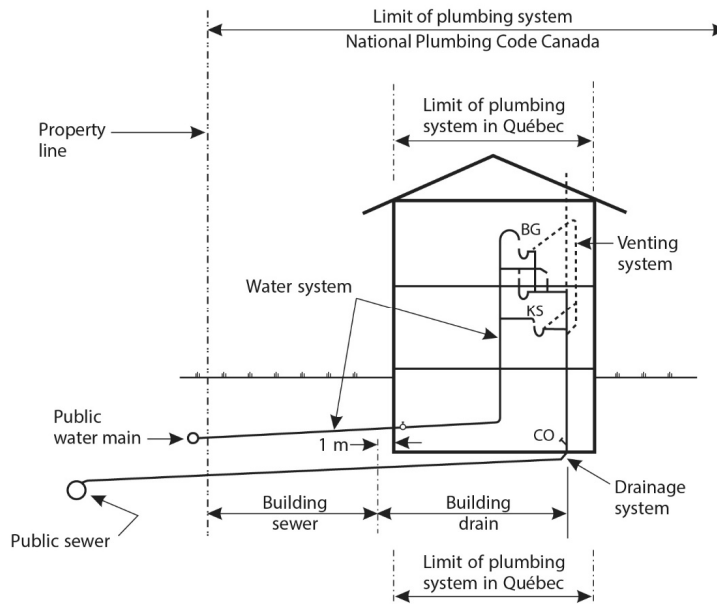

”

(6) in Sentence (1) of Article 3.2.1.1.,

(a) by inserting the following after the functional statement “**F21** To limit or accommodate dimensional change.”:

“**F23** To maintain equipment in place during structural movement.”;

(b) by inserting the following after the functional statement “**F46** To minimize the risk of contamination of *potable* water.”:

“**F60** To control the accumulation and pressure of surface water, groundwater and *sewage*.”

“**F61** To resist the ingress of precipitation, water or moisture from the exterior or from the ground.”.

3.05. The Code is amended in Division B,

(1) by replacing Table 1.3.1.2. in Sentence 1 of Article 1.3.1.2. by the following:

“

Table 1.3.1.2.
Documents Referenced in the National Plumbing Code of Canada
2015

Forming Part of Sentence 1.3.1.2.(1)

Issuing agency	Document Number ⁽¹⁾	Title of Document ⁽²⁾	Code reference
ANSI/CSA	ANSI Z21.10.1-2017/CSA 4.1-2017	Gas Water Heaters – Volume I, Storage Water Heaters with Input Ratings of 75,000 Btu Per Hour or Less	2.2.10.13.(1)
ANSI/CSA	ANSI Z21.10.3-2017/CSA 4.3-2017	Gas Water Heaters – Volume III, Storage Water Heaters with Input Ratings Above 75,000 Btu Per Hour, Circulating and Instantaneous	2.2.10.13.(1)
ANSI/CSA	ANSI Z21.22-2015/CSA 4.4-2015	Relief Valves for Hot Water Supply Systems	2.2.10.11.(1)
ANSI/UL/ULC	ANSI/CAN/UL/ULC 1201:2016	Sensor Operated Backwater Prevention Systems	2.2.10.18.(1)
ASHRAE	2013	ASHRAE Handbook – Fundamentals	A-2.6.3.1.(2)
ASHRAE	2011	ASHRAE Handbook – HVAC Applications	A-2.6.3.1.(2)
ASME/CSA	ASME A112.3.4-2013/CSA B45.9-13	Plumbing fixtures with pumped waste and macerating toilet systems	2.2.2.2.(1)
ASME/CSA	ASME A112.4-2015/CSA B45.16-15	Personal Hygiene Devices for Water Closets	2.2.2.2.(1)

ASME/CSA	ASME A112.4.14-2017/CSA B125.14-17	Manually Operated Valves for use in Plumbing Systems	2.2.10.6.(1)
ASME/CSA	ASME A112.18.1-2018/CSA B125.1-18	Plumbing Supply Fittings	2.2.10.6.(1) 2.2.10.7.(1) 2.2.10.7.(4)
ASME/CSA	ASME A112.18.2-2015/CSA B125.2-15	Plumbing Waste Fittings	2.2.3.3.(1) 2.2.10.6.(6)
ASME/CSA	ASME A112.18.6-2017/CSA B125.6-17	Flexible Water Connectors	2.2.10.6.(1)
ASME/CSA	ASME A112.19.1-2018/CSA B45.2-18	Enamelled Cast Iron and Enamelled Steel Plumbing Fixtures	2.2.2.2.(1)
ASME/CSA	ASME A112.19.2-2018/CSA B45.1-18	Ceramic Plumbing Fixtures	2.2.2.2.(1)
ASME/CSA	ASME A112.19.3-17/CSA B45.4-17	Stainless steel plumbing fixtures	2.2.2.2.(1)
ASME/CSA	ASME A112.19.7-2012/CSA B45.10-12	Hydromassage Bathtub Systems	2.2.2.2.(1)
ASME	A112.6.1M-1997	Floor Affixed Supports for Off-the-Floor Plumbing Fixtures for Public Use	2.2.6.1.(3)
ASME	A112.6.2-2000	Framing-Affixed Supports for Off-the-Floor Water Closets with Concealed Tanks	2.2.6.1.(3)
ASME	A112.6.4-2003	Roof, Deck, and Balcony Drains	2.2.10.20.(1)
ASME	B16.3-2016	Malleable-Iron Threaded Fittings: Classes 150 and 300	2.2.6.6.(1) A-2.2.5., 2.2.6. and 2.2.7.
ASME	B16.4-2016	Gray Iron Threaded Fittings: Classes 125 and 250	2.2.6.5.(1) A-2.2.5., 2.2.6. and 2.2.7.
ASME	B16.5-2017	Pipe Flanges and Flanged Fittings: NPS ½ Through NPS 24 Metric/Inch Standard	2.2.6.12.(1)
ASME	B16.9-2012	Factory-Made Wrought Buttwelding Fittings	2.2.6.11.(1) 2.2.6.14.(1)
ASME	B16.12-2009	Cast Iron Threaded Drainage Fittings	2.2.6.3.(1)
ASME	B16.15-2013	Cast Copper Alloy Threaded Fittings: Classes 125 and 250	2.2.7.3.(1) A-2.2.5., 2.2.6. and 2.2.7.

ASME	B16.18-2012	Cast Copper Alloy Solder-Joint Pressure Fittings	2.2.7.6.(1) 2.2.7.6.(2) A-2.2.5., 2.2.6. and 2.2.7.
ASME	B16.22-2013	Wrought Copper and Copper Alloy Solder-Joint Pressure Fittings	2.2.7.6.(1) A-2.2.5., 2.2.6. and 2.2.7.
ASME	B16.23-2016	Cast Copper Alloy Solder Joint Drainage Fittings: DWV	2.2.7.5.(1) A-2.2.5., 2.2.6. and 2.2.7.
ASME	B16.24-2016	Cast Copper Alloy Pipe Flanges, Flanged Fittings and Valves: Classes 150, 300, 600, 900, 1500, and 2500	2.2.7.2.(1)
ASME	B16.26-2013	Cast Copper Alloy Fittings for Flared Copper Tubes	2.2.7.7.(1) 2.2.7.7.(2)
ASME	B16.29-2012	Wrought Copper and Wrought Copper Alloy Solder-Joint Drainage Fittings – DWV	2.2.7.5.(1) A-2.2.5., 2.2.6. and 2.2.7.
ASME	B31.9-2014	Building Services Piping	2.3.2.8.(1)
ASME	B36.19M-2004	Stainless Steel Pipe	2.2.6.10.(1)
ASPE	2010	Plumbing Engineering Design Handbook, Volume 2	A-2.6.3.1.(2)
ASPE	2012	Plumbing Engineering Design Handbook, Volume 4, Chapter 8, Grease Interceptors	A-2.4.4.3.(1)
ASSE	ANSI/ASSE 1010-2004	Water Hammer Arresters	2.2.10.15.(1)
ASSE/ASME/CSA	ASSE 1002-2015/ASME A112.1002-2015/CSA B125.12-15	Anti-siphon Fill Valves for Water Closet Tanks	2.2.10.10.(2)
ASSE	ASSE 1016-2017/ASME 112.1016-2017/CSA B125.16-17	Performance Requirements for Automatic Compensating Valves for Individual Showers and Tub/Shower Combinations	A-2.2.10.6.(3)
ASSE	1051-2009G	Individual and Branch Type Air Admittance Valves (AAVs) for Sanitary Drainage Systems	2.2.10.16.(1)
ASSE	1061-2015	Performance Requirements for Push-Fit Fittings	2.2.7.9.(1)
ASSE	1072-2007	Performance Requirements for Barrier Type Floor Drain Trap Seal Protection	2.2.10.23.(1)

ASSE/ASME/CSA	ASSE 1037-2015/ASME A112.1037-2015/CSA B125.37-15	Performance Requirements for Pressurized Flushing Devices for Plumbing Fixtures	2.2.10.6.(1)
ASSE/ASME/CSA	ASSE 1070-2015/ASME A112.1070-2015/CSA B125.70-15	Performance Requirements for Water Temperature Limiting Devices	2.2.10.6.(1) 2.2.10.7.(2) 2.2.10.7.(5)
ASTM	A 53/A 53M-12	Pipe, Steel, Black and Hot-Dipped, Zinc-Coated, Welded and Seamless	2.2.6.7.(4) A-2.2.5., 2.2.6. and 2.2.7.
ASTM	A 182/A 182M-18a	Forged or Rolled Alloy and Stainless Steel Pipe Flanges, Forged Fittings, and Valves and Parts for High-Temperature Service	2.2.6.12.(1) 2.2.6.13.(1)
ASTM	A 269/A 269M-15a	Seamless and Welded Austenitic Stainless Steel Tubing for General Service	2.2.6.14.(1) A-2.2.5., 2.2.6. and 2.2.7.
ASTM	A 312/A 312M-17	Seamless, Welded, and Heavily Cold Worked Austenitic Stainless Steel Pipes	2.2.6.10.(1) A-2.2.5., 2.2.6. and 2.2.7.
ASTM	A 351/A 351M-16	Castings, Austenitic, for Pressure-Containing Parts	2.2.6.13.(1)
ASTM	A 403/A 403M-16	Wrought Austenitic Stainless Steel Piping Fittings	2.2.6.11.(1)
ASTM	A 518/A 518M-99	Corrosion-Resistant High-Silicon Iron Castings	2.2.8.1.(1)
ASTM	B 32-08	Solder Metal	2.2.9.2.(1)
ASTM	B 42-15a	Seamless Copper Pipe, Standard Sizes	2.2.7.1.(1) A-2.2.5., 2.2.6. and 2.2.7.
ASTM	B 43-15	Seamless Red Brass Pipe, Standard Sizes	2.2.7.1.(2) A-2.2.5., 2.2.6. and 2.2.7.
ASTM	B 88-16	Seamless Copper Water Tube	2.2.7.4.(1) A-2.2.5., 2.2.6. and 2.2.7.
ASTM	B 306-13	Copper Drainage Tube (DWV)	2.2.7.4.(1) A-2.2.5., 2.2.6. and 2.2.7.
ASTM	B 813-16	Liquid and Paste Fluxes for Soldering of Copper and Copper Alloy Tube	2.2.9.2.(3)

ASTM	B 828-16	Making Capillary Joints by Soldering of Copper and Copper Alloy Tube and Fittings	2.3.2.4.(1)
ASTM	C 1053-00	Borosilicate Glass Pipe and Fittings for Drain, Waste, and Vent (DWV) Applications	2.2.8.1.(1)
ASTM	D 2466-17	Poly(Vinyl Chloride) (PVC) Plastic Pipe Fittings, Schedule 40	2.2.5.6.(2) A-2.2.5., 2.2.6. and 2.2.7.
ASTM	D 2467-15	Poly(Vinyl Chloride) (PVC) Plastic Pipe Fittings, Schedule 80	2.2.5.6.(2) A-2.2.5., 2.2.6. and 2.2.7.
ASTM	D 3138-04	Solvent Cements for Transition Joints Between Acrylonitrile-Butadiene-Styrene (ABS) and Poly(Vinyl Chloride) (PVC) Non-Pressure Piping Components	A-2.2.5.8. to 2.2.5.10.
ASTM	D 3261-16	Butt Heat Fusion Polyethylene (PE) Plastic Fittings for Polyethylene (PE) Plastic Pipe and Tubing	2.2.5.3.(3)
ASTM	F 628-12e2	Acrylonitrile-Butadiene-Styrene (ABS) Schedule 40 Plastic Drain, Waste, and Vent Pipe With a Cellular Core	2.2.5.8.(1) 2.2.5.10.(1) A-2.2.5., 2.2.6. and 2.2.7.
ASTM	F 714-13	Polyethylene (PE) Plastic Pipe (DR-PR) Based on Outside Diameter	2.2.5.4.(1) A-2.2.5., 2.2.6. and 2.2.7.
AWS	ANSI/AWS A5.8M/A5.8:2011- AMD 1	Filler Metals for Brazing and Braze Welding	2.2.9.2.(4)
AWWA	M14-2014	Recommended Practices for Backflow Prevention and Cross-Connection Control	A-2.6.2.4.(2)
AWWA	ANSI/AWWA C104/A21.4-16	Cement-Mortar Lining for Ductile-Iron Pipe and Fittings	2.2.6.4.(2)
AWWA	ANSI/AWWA C110/A21.10-12	Ductile-Iron and Gray-Iron Fittings	2.2.6.4.(3)
AWWA	ANSI/AWWA C111/A21.11-17	Rubber-Gasket Joints for Ductile-Iron Pressure Pipe and Fittings	2.2.6.4.(4)
AWWA	ANSI/AWWA C151/A21.51-17	Ductile-Iron Pipe, Centrifugally Cast, for water	2.2.6.4.(1) A-2.2.5., 2.2.6. and 2.2.7.
AWWA	ANSI/AWWA C228-14	Stainless-Steel Pipe Flanges for Water Service – Sizes 2 in. through 72 in. (50 mm through 1,800 mm)	2.2.6.12.(1)

BNQ	BNQ 2622-126-2009	Reinforced Concrete and Unreinforced Concrete Pipes and Monolithic Lateral Connections for Evacuation of Domestic Wastewater and Storm Water	2.2.5.1.(1)
BNQ	NQ 3623-085-2002	Ductile-Iron Pipe for Water Pressure Piping Systems - Characteristics and Test Methods	2.2.6.4.(1)
BNQ	BNQ 3624-027-2016	Polyethylene (PE) Pipe for the Transport of Fluids Under Pressure	2.2.5.3.(1)
BNQ	BNQ 3624-120-2016	Smooth Inside Wall Open-Profile Polyethylene (PE) Pipe and Polyethylene Fittings for Storm Sewers, Culverts and Soil Drainage	2.2.5.8.(1)
BNQ	BNQ 3624-130-2015	Unplasticized Poly(Vinyl Chloride) [PVC-U] Pipe and Fittings – Pipes of 150 mm in Diameter or Smaller	2.2.5.8.(1)
BNQ	BNQ 3624-135-2015	Unplasticized Poly(Vinyl Chloride) [PVC-U] Pipe and Fittings – Pipes of 200 mm in Diameter or Larger for Sewage and Soil Drainage	2.2.5.8.(1)
BNQ	BNQ 3624-250-2015	Unplasticized Poly(Vinyl Chloride) [PVC-U] Pipe and Fittings – Rigid Pipe for Pressurized Water Supply and Distribution	2.2.5.6.(1)
CCBFC	NRCC 56190	National Building Code of Canada 2015	1.1.1.1.(2) ⁽³⁾ 1.1.1.1.(3) ⁽³⁾ 1.4.1.2.(1) ⁽³⁾ A- 2.2.1.1.(1) ⁽³⁾ A- 3.2.1.1.(1) ⁽³⁾ 2.1.3.1.(1) 2.1.4.1.(1) 2.2.5.10.(2) 2.2.5.10.(3) 2.2.6.7.(3) 2.4.3.1.(1) 2.4.10.4.(1) A-2.2.5., 2.2.6. and 2.2.7. A-2.4.10. A- 2.4.10.4.(1) A-2.6.3.1.(2)
CCBFC	NRCC 56191	National Energy Code of Canada for Buildings 2015	A- 2.2.1.1.(1) ⁽³⁾ A- 3.2.1.1.(1) ⁽³⁾

CCBFC	NRCC 56192	Naitonal Fire Code of Canada 2015	A-2.2.1.1.(1) ⁽³⁾ A-3.2.1.1.(1) ⁽³⁾ 2.5.5.2.
CSA	A60.1-M1976	Vitrified Clay Pipe	2.2.5.2.(1) A-2.2.5., 2.2.6. and 2.2.7.
CSA	A60.3-M1976	Vitrified Clay Pipe Joints	2.2.5.2.(2)
CSA	A257.1-14	Non-Reinforced Circular Concrete Culvert, Storm Drain, Sewer Pipe, and Fittings	2.2.5.1.(1) A-2.2.5., 2.2.6. and 2.2.7.
CSA	A257.2-14	Reinforced Circular Concrete Culvert, Storm Drain, Sewer Pipe, and Fittings	2.2.5.1.(1) A-2.2.5., 2.2.6. and 2.2.7.
CSA	A257.3-14	Joints for Circular Concrete Sewer and Culvert Pipe, Manhole Sections, and Fittings Using Rubber Gaskets	2.2.5.1.(2)
CSA	A257.4-14	Precast Reinforced Circular Concrete Manhole Sections, Catch Basins, and Fittings	2.2.5.1.(5)
CSA	CAN/CSA-B45 Series-02	Sanitary Installations	2.2.2.2.(1)
CSA	B45.11-17/IAPMO Z401-2017	Glass Plumbing Fixtures	2.2.2.2.(1)
CSA	B45.5-17/IAPMO Z124-2017	Plastic Plumbing Fixtures	2.2.2.2.(1)
CSA	B45.8-13/IAPMO Z403-2013	Terrazzo, Concrete, and Natural Stone Plumbing Fixtures	2.2.2.2.(1)
CSA	CSA B45.12-13/IAPMO Z402-2013	Aluminium and Copper Plumbing Fixtures	2.2.2.2.(1)
CSA	B55.2-15	Drain water heat recovery units	2.2.10.25.(1)
CSA	B64.0-11	Definitions, General Requirements, and Test Methods for Vacuum Breakers and Backflow Preventers	2.2.10.10.(1)
CSA	B64.1.1-11	Atmospheric Vacuum Breakers (AVB)	2.2.10.10.(1)
CSA	B64.1.2-11	Pressure Vacuum Breakers (PVB)	2.2.10.10.(1)
CSA	B64.1.3-11	Spill-resistant Pressure Vacuum Breakers (SRPVB)	2.2.10.10.(1)
CSA	B64.1.4-11	Vacuum Breaker, Air Space Type (ASVB)	2.2.10.10.(1)
CSA	B64.2-11	Hose Connection Vacuum Breakers (HCVB)	2.2.10.10.(1)
CSA	B64.2.1-11	Hose Connection Dual Check Vacuum Breakers (HCDVB)	2.2.10.10.(1)

CSA	B64.2.2-11	Hose Connection Vacuum Breakers (HCVB) with Automatic Draining Feature	2.2.10.10.(1)
CSA	B64.3-11	Dual Check Valve Backflow Preventers with Atmospheric Port (DCAP)	2.2.10.10.(1)
CSA	B64.4-11	Reduced Pressure Principle (RP) Backflow Preventers	2.2.10.10.(1) 2.6.2.4.(2) 2.6.2.4.(4)
CSA	B64.4.1-11	Reduced Pressure Principle Backflow Preventers for Fire Protection Systems (RPF)	2.6.2.4.(2) 2.6.2.4.(4) A-2.6.2.4.(2)
CSA	B64.5-11	Double Check Valve (DCVA) Backflow Preventers	2.2.10.10.(1) 2.6.2.4.(2)
CSA	B64.5.1-11	Double Check Valve Backflow Preventers for Fire Protection Systems (DCVAF)	2.6.2.4.(2) A-2.6.2.4.(2)
CSA	B64.6-11	Dual Check Valve (DuC) Backflow Preventers	2.2.10.10.(1) 2.6.2.4.(2)
CSA	B64.6.1-11	Dual Check Valve Backflow Preventers for Fire Protection Systems (DuCF)	2.6.2.4.(2) A-2.6.2.4.(2)
CSA	B64.7-11	Laboratory Faucet Vacuum Breakers (LFVB)	2.2.10.10.(1)
CSA	B64.8-11	Dual Check Valve Backflow Preventers with Intermediate Vent (DuCV)	2.2.10.10.(1)
CSA	B64.9-11	Single Check Valve Backflow Preventers for Fire Protection Systems (SCVAF)	2.6.2.4.(2) A-2.6.2.4.(2)
CSA	B64.10-17	Selection and Installation of Backflow Preventers	2.6.2.1.(3) 2.6.2.1.(4) 2.6.2.13.(1)
CSA	B64.10.1-17	Maintenance and field testing of backflow preventers	2.6.2.1.(4) A-2.6.2.1.(3)
CSA	B70-12	Cast Iron Soil Pipe, Fittings and Means of Joining	2.2.6.1.(1) 2.4.6.4.(2) 2.2.10.18.(1) A-2.2.5., 2.2.6. and 2.2.7.
CSA	B70.1-03	Frames and Covers for Maintenance Holes and Catchbasins	2.2.6.2.(1)
CSA	B79-08	Commercial and residential drains and cleanouts	2.2.10.19.(1)
CSA	B125.3-18	Plumbing Fittings	2.2.10.6.(1) 2.2.10.7.(2) 2.2.10.7.(3) 2.2.10.7.(5) 2.2.10.21.(1) A- 2.6.1.11.(1)
CSA	CSA B125.5-11/IAPMO Z600-11	Flexible Water Connectors With Excess Flow Shut-off Devices	2.2.10.6.(1)

CSA	CAN/CSA-B128.1-06	Design and Installation of Non-Potable Water Systems	2.7.4.1.(1)
CSA	B137.1-17	Polyethylene (PE) Pipe, Tubing, and Fittings for Cold-Water Pressure Services	2.2.5.3.(1) A-2.2.5., 2.2.6. and 2.2.7.
CSA	B137.2-17	Polyvinylchloride (PVC) Injection-Moulded Gasketed Fittings for Pressure Applications	2.2.5.6.(3) A-2.2.5., 2.2.6. and 2.2.7.
CSA	B137.3-17	Rigid Polyvinylchloride (PVC) Pipe and Fittings for Pressure Applications	2.2.5.6.(1) A-2.2.5., 2.2.6. and 2.2.7.
CSA	B137.5-17	Crosslinked Polyethylene (PEX) Tubing Systems for Pressure Applications	2.2.5.5.(1) A-2.2.5., 2.2.6. and 2.2.7. A-2.2.5.6.(1)
CSA	B137.6-17	Chlorinated Polyvinylchloride (CPVC) Pipe, Tubing, and Fittings for Hot- and Cold-Water Distribution Systems	2.2.5.7.(1) A-2.2.5., 2.2.6. and 2.2.7. A-2.2.5.9. to 2.2.5.11.
CSA	B137.9-17	Polyethylene/Aluminum/Polyethylene (PE-AL-PE) Composite Pressure-Pipe Systems	2.2.5.11.(1) A-2.2.5., 2.2.6. and 2.2.7. A- 2.2.5.11.(1)
CSA	B137.10-17	Crosslinked Polyethylene/Aluminum/Crosslinked Polyethylene (PEX-AL-PEX) Composite Pressure-Pipe Systems	2.2.5.11.(4) 2.2.5.12.(1) A-2.2.5., 2.2.6. and 2.2.7. A- 2.2.5.12.(1)
CSA	B137.11-17	Polypropylene (PP-R) Pipe and Fittings for Pressure Applications	2.2.5.13.(1) A-2.2.5., 2.2.6. and 2.2.7. A- 2.2.5.13.(1)
CSA	B137.18-17	Polyethylene of Raised Temperature Resistance (PE-RT) Tubing Systems for Pressure Applications	2.2.5.14.(1) A- 2.2.5.14.(1) A-2.2.5., 2.2.6. and 2.2.7.

CSA	B140.12-03	Oil-Burning Equipment: Service Water Heaters for Domestic Hot Water, Space Heating, and Swimming Pools	2.2.10.13.(1)
CSA	B158.1-1976	Cast Brass Solder Joint Drainage, Waste and Vent Fittings	2.2.10.1.(1)
CSA	CAN/CSA-B181.1-15	Acrylonitrile-Butadiene-Styrene (ABS) Drain, Waste, and Vent Pipe and Pipe Fittings	2.2.5.8.(1) 2.2.5.9.(1) 2.2.5.10.(1) 2.2.10.18.(1) 2.4.6.4.(2) A-2.2.5., 2.2.6. and 2.2.7. A-2.2.5.8. to 2.2.5.10.
CSA	CAN/CSA-B181.2-15	Polyvinylchloride (PVC) and Chlorinated Polyvinylchloride (CPVC) Drain, Waste, and Vent Pipe and Pipe Fittings	2.2.5.8.(1) 2.2.5.9.(1) 2.2.5.10.(1) 2.2.10.18.(1) 2.4.6.4.(2) A-2.2.5., 2.2.6. and 2.2.7. A-2.2.5.8. to 2.2.5.10.
CSA	CAN/CSA-B181.3-15	Polyolefin and Polyvinylidene Fluoride (PVDF) Laboratory Drainage Systems	2.2.8.1.(1) A-2.2.5., 2.2.6. and 2.2.7.
CSA	CAN/CSA-B182.1-15	Plastic Drain and Sewer Pipe and Pipe Fittings	2.2.5.8.(1) 2.4.6.4.(2) 2.2.10.18.(1) A-2.2.5., 2.2.6. and 2.2.7.
CSA	CAN/CSA-B182.2-15	PSM Type Polyvinylchloride (PVC) Sewer Pipe and Fittings	2.2.5.8.(1) A-2.2.5., 2.2.6. and 2.2.7.
CSA	CAN/CSA-B182.4-15	Profile Polyvinylchloride (PVC) Sewer Pipe and Fittings	2.2.5.8.(1) A-2.2.5., 2.2.6. and 2.2.7.
CSA	CAN/CSA-B182.6-15	Profile Polyethylene (PE) Sewer Pipe and Fittings for LeakProof Sewer Applications	2.2.5.8.(1) A-2.2.5., 2.2.6. and 2.2.7.
CSA	CAN/CSA-B182.8-15	Profile polyethylene (PE) storm sewer and drainage pipe and fittings	2.2.5.8.(1)
CSA	B242-05	Groove and Shoulder-Type Mechanical Pipe Couplings	2.2.10.4.(1)

CSA	B272-93	Prefabricated Self-Sealing Roof Vent Flashings	2.2.10.14.(2)
CSA	CAN/CSA-B356-10	Water Pressure Reducing Valves for Domestic Water Supply Systems	2.2.10.12.(1)
CSA	B481 Series-12	Grease Interceptors	2.2.3.2.(3) A-2.4.4.3.(1)
CSA	B481.0-12	Material, Design, and Construction Requirements for Grease Interceptors	2.2.3.2.(3)
CSA	B481.3-12	Sizing, Selection, Locations, and Installation of Grease Interceptors	2.2.3.2.(4)
CSA	B481.4-12	Maintenance of Grease Interceptors	A-2.2.3.2.(3)
CSA	CAN/CSA-B483.1-07	Drinking Water Treatment Systems	2.2.10.17.(1) 2.2.10.17.(2) 2.2.10.17.(3) 2.2.10.17.(4) 2.2.10.17.(5)
CSA	B602-16	Mechanical Couplings for Drain, Waste, and Vent Pipe and Sewer Pipe	2.2.10.4.(2)
CSA	C22.2 n° 110-94	Construction and Test of Electric Storage-Tank Water Heaters	2.2.10.13.(1)
CSA	C22.2 n° 64-10	Household Cooking and Liquid-Heating Appliances	2.2.10.13.(1)
CSA	CAN/CSA-E60335-2-35-01	Safety of Household and Similar Electrical Appliances - Part 2-35: Particular Requirements for Instantaneous Water Heaters	2.2.10.13.(1)
CSA	CAN/CSA-F379 SERIES-F09 (excluding Supplement F379S1-11)	Packaged Solar Domestic Hot Water Systems (Liquid-to-Liquid Heat Transfer)	2.2.10.13.(1)
CSA	CAN/CSA-F383-08	Installation of packaged solar domestic hot water systems	2.6.1.8.(1)
CSA	CAN/CSA-G401-14	Corrugated Steel Pipe Products	2.2.6.8.(1) A-2.2.5., 2.2.6. and 2.2.7.
ISO	11143-2008	Amalgam separators	2.2.3.2.(5)
McGraw-Hill	2009	International Plumbing Codes Handbook	A-2.6.3.
MSS	SP-58-2009	Pipe Hangers and Supports - Materials, Design, Manufacture, Selection, Application, and Installation	2.2.10.22.(1)
NFPA	13D-2016	Installation of Sprinkler Systems in One- and Two-Family Dwellings and Manufactured Homes	2.6.3.1.(3)
NIST	Building Materials and Structures Report BMS-79, 1941	Water-Distributing Systems for Buildings	A-2.6.3.

NSF	NSF/ANSI 53-2016	Drinking Water Treatment Units – Health Effects	2.2.10.17.(4)
NSF	NSF/ANSI 55-2016	Ultraviolet Microbiological Water Treatment Systems	2.2.10.17.(1)
NSF	NSF/ANSI 61-2016	Drinking Water System Components – Health Effects	2.2.10.24.(1)
NSF	NSF/ANSI 62-2016	Drinking Water Distillation Systems	2.2.10.17.(3)
TIAC	2013	Mechanical Insulation Best Practices Guide	A-2.3.5.3.
ULC	CAN/ULC-S114-05	Determination of Non-Combustibility in Building Materials	1.4.1.2.(1) ⁽³⁾
ULC	CAN/ULC-S656-14	Standard for Oil-Water Separators	2.2.3.2.(6)

(1) Some documents may have been reaffirmed or reapproved. Check with the applicable issuing agency for up-to-date information.

(2) Some titles have been abridged to omit superfluous wording.

(3) Code reference is in Division A.

”;

(2) in Sentence (1) of Article 1.3.2.1.,

(a) by inserting the following after “AWWA...American Water Works Association (www.awwa.org)”:

“BNQ...Bureau de normalisation du Québec (www.bnq.qc.ca)”;

(b) by inserting the following after “CSA...CSA Group (www.csagroup.org)”:

“ISO...International Organization for Standardization (www.iso.org);

MSS...Manufacturers Standardization Society of the Valve and Fittings Industry (www.mss-hq.com)”;

(c) by inserting the following after “NPC...National Plumbing Code of Canada 2015”:

“NSF...NSF International (www.nsf.com)”;

(3) by adding the following after Subsection 2.1.3.:

“2.1.4. Structural Movement

2.1.4.1. Structural Movement

(1) *Plumbing systems of buildings* subject to Chapter I of the *Construction Code* and to which Part 4 of Division B of the NBC applies shall be designed and installed to accommodate the maximum relative structural movement provided for in the construction of the *building*. (See Article 4.1.3.5., Subsection 4.1.8., Sentence 4.1.3.3.(2) and Article A-6.2.1.4. of Division B of the NBC for information on the types of structural movements that may be encountered.);

- (4) in Sentence (1) of Article 2.2.2.2.,
- (a) by striking out “and” in Clause (g);
 - (b) in the French text by replacing “toilettes à broyeur” in Clause (h) by “systèmes de toilettes à broyeur”;
 - (c) by adding the following after Clause (h):
 - “(i) toilet seats with bidet functionality shall conform to ASME A112.4/CSA B45.16, “Personal Hygiene Devices for Water Closets”,
 - (j) glass *lavatories* shall conform to CSA B45.11/IAPMO Z401, “Glass Plumbing Fixtures”,
 - (k) terrazzo, concrete or natural stone *plumbing fixtures* shall conform to CSA B45.8/IAPMO Z403, “Terrazzo, Concrete and Natural Stone Plumbing Fixtures”, and
 - (l) aluminum or copper *plumbing fixtures* shall conform to CSA B45.12/IAPMO Z402, “Aluminum and Copper Plumbing Fixtures”.”;
- (5) in Article 2.2.3.2., by replacing Sentence (3) by the following:
- “(3) Grease *interceptors* shall conform to CSA-B481 Series, “Grease Interceptors”. (See Note A-2.2.3.2.(3).)
- (4) Grease *interceptors* shall be selected and installed in conformance with CSA B481.3, “Sizing, Selection, Location, and Installation of Grease Interceptors”.
- (5) Amalgam *separators* shall conform to ISO 11143, “Amalgam Separators”.
- (6) Oil *interceptors* shall conform to CAN/ULC-S656, “Standard for Oil-Water Separators”.;”;
- (6) in Article 2.2.4.2., by replacing Sentence (1) by the following:
- “(1) Except as provided in Article 2.4.3.7., a single or double sanitary T fitting shall not be used in a *nominally horizontal* pipe, except that a single sanitary T fitting may be used to connect a *vent pipe*.;”;
- (7) by adding “The prohibition also applies to any combination of 45° elbows displaying the same characteristics.” at the end of Sentence (1) of Article 2.2.4.3;
- (8) in Article 2.2.5.1.,
- (a) by striking out “or” at the end of Clause (a) of Sentence (1);

(b) by replacing “and Fittings” in Clause (b) of Sentence (1) by “and Fittings”, or”;

(c) by adding the following after Clause (b) of Sentence (1):

“(c) BNQ 2622-126, “Reinforced Concrete and Unreinforced Concrete Pipes and Monolithic Lateral Connections for Evacuation of Domestic Wastewater and Storm Water”.”;

(9) in Article 2.2.5.3., by replacing Sentence (1) by the following:

“(1) Polyethylene water pipe, tubing, and fittings shall conform to Series 160 of

(a) CSA-B137.1, “Polyethylene (PE) Pipe, Tubing, and Fittings for Cold-Water Pressure Services”, or

(b) BNQ 3624-027, “Polyethylene (PE) Pipe for the Transport of Fluids Under Pressure”.”;

(10) in Article 2.2.5.5., by replacing Sentence (1) by the following:

“(1) Crosslinked polyethylene pipes and fittings approved by the manufacturer and used in hot and cold *potable water systems* shall conform to CSA-B137.5, “Cross-Linked Polyethylene (PEX) Tubing Systems for Pressure Applications” (see Note A-2.2.5.5.(1)).”;

(11) in Article 2.2.5.6., by replacing Clause (a) of Sentence (1) by the following:

“(a) conform to

(i) CSA-B137.3, “Rigid Polyvinylchloride (PVC) Pipe and Fittings for Pressure Applications”, or

(ii) BNQ 3624-250, “Unplasticized Poly(Vinyl Chloride) [PVC-U] Pipe and Fittings - Rigid Pipe for Pressurized Water Supply and Distribution”.”;

(12) in Article 2.2.5.8.,

(a) by striking out “or” at the end of Clause (g) of Sentence (1);

(b) by replacing “non-perforated pipes.” in Clause (h) of Sentence (1) by “non-perforated pipes,”;

(c) by adding the following after Clause (h) of Sentence (1):

“(i) BNQ 3624-120, “Smooth Inside Wall Open-Profile Polyethylene (PE) Pipe and Polyethylene (PE) Fittings for Storm Sewers, Culverts and Soil Drainage”,

(j) BNQ 3624-130, “Unplasticized Poly(Vinyl Chloride) [PVC-U] Pipe and Fittings - Pipes of 150 mm in Diameter or Smaller”, or

(k) BNQ 3624-135, “Unplasticized Poly(Vinyl Chloride) [PVC-U] Pipe and Fittings - Pipes of 200 mm in Diameter or Larger for Sewage and Soil Drainage”;

(13) by adding the following after Article 2.2.5.13.:

“2.2.5.14. Pipes and Fittings Made of Polyethylene of Raised Temperature Resistance

(1) Pipes made of polyethylene of raised temperature resistance (PE-RT) and fittings approved by the manufacturer and used in hot and cold *potable water systems* shall conform to CSA-B137.18, “Polyethylene of Raised Temperature Resistance (PE-RT) Tubing Systems for Pressure Applications” (see Note A-2.2.5.14.(1).);

(14) in Article 2.2.6.1., by adding the following after Sentence (2):

“(3) Wall supports for water closets shall conform to

(a) ASME A112.6.1M, “Supports for Off-the-Floor Plumbing Fixtures for Public Use”, or

(b) ASME A112.6.2, “Framing-Affixed Supports for Off-the-Floor Water Closets with Concealed Tanks”;

(15) in Article 2.2.6.4., by replacing Sentence (1) by the following:

“(1) Cast-iron water pipes shall conform to

(a) ANSI/AWWA-C151/A21.51, “Ductile-Iron Pipe, Centrifugally Cast, for Water”, or

(b) NQ 3623-085, “Ductile-Iron Pipes for Water Pressure Piping Systems - Characteristics and Test Methods”;

(16) by adding the following after Article 2.2.7.8.:

“2.2.7.9. Quick Connection Push-Fit Fittings

(1) Quick connection push-fit fittings shall conform to ASSE 1061, “Performance Requirements for Push-Fit Fittings”;

(17) in Article 2.2.10.5., by inserting “, except at the point of connection to a standpipe system” after “*water systems*” in Sentence (1);

(18) in Article 2.2.10.6., by replacing Sentence (1) by the following:

“(1) Plumbing supply fittings shall conform to

(a) ASME A112.18.1/CSA B125.1, “Plumbing Supply Fittings”,

- (b) CSA B125.3, "Plumbing Fittings",
- (c) CSA B125.5/IAPMO Z600, "Flexible Water Connectors with Excess Flow Shut-Off Devices",
- (d) ASME A112.18.6/CSA B125.6, "Flexible Water Connectors",
- (e) ASME A112.4.14/CSA B125.14, "Manually Operated Valves for Use in Plumbing Systems",
- (f) ASSE 1037/ASME A112.1037/CSA B125.37, "Performance Requirements for Pressurized Flushing Devices for Plumbing Fixtures", or
- (g) ASSE 1070/ASME A112.1070/CSA B125.70, "Performance Requirements for Water Temperature Limiting Devices".;

(19) by replacing Article 2.2.10.7. by the following:

**"2.2.10.7. Water Temperature Control
(See Note A-2.2.10.7.)**

(1) Except as provided in Sentences (2) to (4), valves supplying shower heads or bathtubs shall be of the pressure-balanced, thermostatic, or combination pressure-balanced/thermostatic type and conform to ASME A112.18.1/CAN/CSA B125.1, "Plumbing Supply Fittings".

(2) Valves supplying only bathtubs need not be of one of the types referred to in Sentence (1) if the hot water supply is controlled by a thermostatic-mixing valve conforming to CAN/CSA-B125.3, "Plumbing Fittings", or an automatic temperature-limiting device conforming to ASSE 1070/ASME A112.1070/CSA B125.70, "Performance Requirements for Water Temperature Limiting Devices".

(3) Valves supplying only shower heads need not be of one of the types referred to in Sentence (1) if the water supply is controlled by an automatic compensating valve conforming to CAN/CSA B125.3, "Plumbing Fittings".

(4) Except as provided in Sentence (5), valves supplying shower heads or bathtubs of a care occupancy or private seniors' residence within the meaning of the Act respecting health services and social services (chapter S-4.2) shall be of the thermostatic or combination pressure-balanced/thermostatic type and conform to ASME A112.18.1/CAN/CSA B125.1, "Plumbing Supply Fittings". For the purposes of this Article, "care occupancy" means a building or part of a building housing persons who, because of their physical or mental state, need medical care or treatment.

(5) Valves supplying only bathtubs of a care occupancy or private seniors' residence need not be of one of the types referred to in Sentence (4) if the hot water supply is controlled by a thermostatic-mixing valve conforming to CAN/CSA B125.3, "Plumbing Fittings", or an automatic temperature-limiting device conforming to ASSE 1070/ASME A112.1070/CSA B125.70, "Performance Requirements for Water Temperature Limiting Devices", installed within the limits of a bathroom.

(6) Valves, mixing valves and limiting devices covered by Sentences (1) to (3) shall be adjusted to provide a water outlet temperature that does not exceed 49 °C. Those covered by Sentences (4) and (5) shall be adjusted to provide a water outlet temperature that does not exceed 43 °C.”;

(20) in Article 2.2.10.10.,

(a) by replacing clauses (e) to (m) of Sentence (1) by the following:

“(e) CSA B64.1.4, “Vacuum Breaker, Air Space Type (ASVB)”,

(f) CSA B64.2, “Hose Connection Vacuum Breakers (HCVB)”,

(g) CSA B64.2.1, “Hose Connection Vacuum Breakers (HCVB) with Manual Draining Feature”,

(h) CSA B64.2.2, “Hose Connection Vacuum Breakers (HCVB) with Automatic Draining Feature”,

(i) CSA B64.3, “Dual Check Valve Backflow Preventers with Atmospheric Port (DCAP)”,

(j) CSA B64.4, “Reduced Pressure Principle (RP) Backflow Preventers”,

(k) CSA B64.5, “Double Check Valve (DCVA) Backflow Preventers”,

(l) CSA B64.6, “Dual Check Valve (DuC) Backflow Preventers”,

(m) CSA B64.7, “Laboratory Faucet Vacuum Breakers (LFVB)”, or

(n) CSA B64.8, “Dual Check Valve Backflow Preventers with Intermediate Vent (DuCV)”.”;

(b) by replacing “CSA B125.3, “Plumbing Fittings”.” in Sentence (2) by “ASSE 1002/ASME A112.1002/CSA B125.12, “Anti-Siphon Fill Valves for Water Closet Tanks”.”;

(21) by replacing “*brise-vide*” in the French text of Sentence (1) of Article 2.2.10.11 by “*antivide*”;

(22) in Article 2.2.10.13.,

(a) by striking out “**Solar Domestic**” in the title;

(b) by replacing Sentence (1) by the following:

“(1) Service water heaters shall conform to

(a) ANSI Z21.10.1/CSA 4.1, “Gas Water Heaters - Volume I, Storage Water Heaters with Input Ratings of 75,000 Btu per Hour or Less”,

(b) ANSI Z21.10.3/CSA 4.3, “Gas Water Heaters - Volume III, Storage Water Heaters with Input Ratings above 75,000 Btu per Hour, Circulating and Instantaneous”,

(c) CAN/CSA-C22.2 No. 110, “Construction and Test of Electric Storage-Tank Water Heaters”,

(d) CSA B140.12, “Oil-Burning Equipment: Service Water Heaters for Domestic Hot Water, Space Heating, and Swimming Pools”,

(e) CAN/CSA-F379 SERIES, “Solar Domestic Hot Water Systems (Liquid-to-Liquid Heat Transfer)”,

(f) CSA C22.2 No. 64, “Household Cooking and Liquid-Heating Appliances”, or

(g) CAN/CSA-E60335-2-35, “Safety of Household and Similar Electrical Appliances - Part 2-35: Particular Requirements for Instantaneous Water Heaters”.”;

(23) in Article 2.2.10.17.,

(a) by adding “**Potable**” at the beginning of the title;

(b) by replacing Sentence (1) by the following:

“(1) *Potable* water disinfection units using ultraviolet designed to meet the requirements of the Regulation respecting the quality of drinking water (chapter Q-2, r. 40) shall conform to

(a) NSF/ANSI 55, “Ultraviolet Microbiological Water Treatment Systems”, or

(b) CAN/CSA-B483.1, “Drinking Water Treatment Systems”, if they are designed to be installed at the point of use.

(2) Reverse osmosis *potable* water treatment systems installed at the point of use and designed to meet the requirements of the Regulation respecting the quality of drinking water shall conform to CAN/CSA-B483.1, “Drinking Water Treatment Systems”.

(3) *Potable* water distillation systems designed to meet the requirements of the Regulation respecting the quality of drinking water shall conform to

(a) NSF/ANSI 62, “Drinking Water Distillation Systems”, or

(b) CAN/CSA-B483.1, “Drinking Water Treatment Systems”, if they are designed to be installed at the point of use.

(4) *Potable* water treatment units not covered by Sentences (1) to (3) and designed to meet the requirements of the Regulation respecting the quality of drinking water shall conform to

(a) NSF/ANSI 53, “Drinking Water Treatment Units - Health Effects”, or

(b) CAN/CSA-B483.1, “Drinking Water Treatment Systems”, if they are designed to be installed at the point of use.

(5) *Potable* water treatment units not covered by Sentences (1) to (4) shall conform to CAN/CSA-B483.1, “Drinking Water Treatment Systems”.

(24) by adding the following after Article 2.2.10.17.:

“2.2.10.18. Backwater Valves

(1) *Backwater valves* shall conform to

(a) CSA-B70, “Cast Iron Soil Pipe, Fittings, and Means of Joining”,

(b) CAN/CSA-B181.1, “Acrylonitrile-Butadiene-Styrene (ABS) Drain, Waste, and Vent Pipe and Pipe Fittings”,

(c) CAN/CSA-B181.2, “Polyvinylchloride (PVC) and Chlorinated Polyvinylchloride (CPVC) Drain, Waste, and Vent Pipe and Pipe Fittings”,

(d) CAN/CSA-B182.1, “Plastic Drain and Sewer Pipe and Pipe Fittings”, or

(e) ANSI/CAN/UL/ULC 1201, “Sensor Operated Backwater Prevention Systems”.

2.2.10.19. Floor Drains and Shower Drains

(1) Floor drains, including *emergency floor drains*, and shower drains installed on the floor shall conform to CSA-B79, “Commercial and Residential Drains and Cleanouts”.

2.2.10.20. Roof Drains

(1) *Roof drains* shall conform to ASME A112.6.4, “Roof, Deck, and Balcony Drains”.

2.2.10.21. Trap Seal Primer Devices

(1) *Trap seal primer devices* shall conform to CAN/CSA-B125.3, “Plumbing Fittings”.

2.2.10.22. Pipe Hangers and Supports

(1) Manufactured pipe hangers and supports shall conform to MSS SP-58, “Pipe Hangers and Supports – Materials, Design, Manufacture, Selection, Application, and Installation”.

2.2.10.23. Floor Drain Trap Seals

(1) Floor drain *trap seals* used to maintain *trap seal depth* shall conform to ASSE 1072, “Performance Requirements for Barrier Type Floor Drain Trap Seal Protection Devices”.

2.2.10.24. Expansion Tanks

(1) Expansion tanks for *potable water distribution systems* shall conform to NSF/ANSI 61, “Drinking Water System Components – Health Effects”.

2.2.10.25. Heat Recovery Units

(1) Vertical drain water heat recovery units shall conform to CSA B55.2, “Drain Water Heat Recovery Units.”;

(25) by replacing “Running thread” in Sentence (1) of Article 2.3.3.4. by “Subject to Sentence 2.4.6.3.(6), running thread”;

(26) in Article 2.3.4.5.,

(a) by inserting, in Table 2.3.4.5., after

PEX plastic pipe	0.08	None
------------------	------	------

the following:

PE-RT pipe	0.08	None
------------	------	------

(b) by inserting “PE-RT,” after “PEX,” in Sentence (4);

(c) in the French text by replacing “Les suspentes des tuyaux *d’allure horizontale* doivent être :” in Sentence (5) by “Lorsque des suspentes pour tuyaux *d’allure horizontale* sont utilisées, elles doivent être :”;

(27) by replacing “a water pressure test or an air pressure test” in Sentence (1) of Article 2.3.6.1. by “a water pressure test, smoke pressure test or air pressure test”;

(28) by inserting “, smoke test” after “air pressure test” in Sentence (1) of Articles 2.3.6.2. and 2.3.6.3.;

(29) by adding the following after Article 2.3.6.7.:

“2.3.6.8. Smoke Tests

(1) Where a smoke test is made

(a) smoke from smoke-generating machines shall be forced into the system, and

(b) a pressure equivalent to a 25 mm water column shall be maintained.”;

(30) in Article 2.4.2.1.,

(a) by replacing subclauses (v) and (vi) of Clause (e) of Sentence (1) by the following:

“(v) a water treatment device,

(vi) a drain or overflow from a *water system* or a heating system,

(vii) a drain from an ice machine, or

(viii) a drain from a heating, air-conditioning or ventilation system (see Note A-2.4.2.1.(1)(a)(ii) and (e)(vi)).”;

(b) by replacing Sentence (2) by the following:

“(2) Where the upper vertical part of an offset *soil-or-waste stack* receives water from *fixtures* from more than one *storey*, a connection in that offset *soil-or-waste stack* shall not be less than 1.5 m downstream from the base of the upper section of the *soil-or-waste stack* or from another connection receiving *sewage* from another *soil-or-waste stack* connected to the *offset*.

(See Note A-2.4.2.1.(2).)”;

(c) by replacing Sentences (4) and (5) by the following:

“(4) Every connection at the bottom of a *soil-or-waste stack* shall be more than 1.5 m in a *building drain* or a *branch* receiving sewage from the *soil-or-waste stack*.
(See Note A-2.4.2.1.(4)).

(5) Every *trap arm* of a bathtub, shower, bidet, floor drain or service sink installed on the floor shall have a *nominally horizontal* part not less than 450 mm in *developed length*. The *developed length* of the *trap arm* of a floor drain shall be increased to 1.5 m if it is connected not more than 3 m downstream from the bottom of a *soil-or-waste stack* or a *leader*.
(See Note A-2.4.2.1.(5)).

(6) Where a change of direction greater than 45° occurs in a *soil-or-waste pipe* that serves more than one clothes washer or domestic kitchen sink, and in which pressure zones are created by detergent suds, no *soil-or-waste pipe* shall serve for connecting other *soil-or-waste pipe* over a length not less than

(a) 40 times the *size* of the *soil-or-waste pipe* or 2.44 m maximum vertical, whichever is less, before changing direction, and

(b) 10 times the *size* of the *nominally horizontal soil-or-waste pipe* after changing direction.
(See Note A-2.4.2.1.(6) and (7)).

(7) Where a *vent pipe* is connected into the suds pressure zone referred to in Sentence (6), no other *vent pipe* shall be connected to that *vent pipe* within the height of the suds pressure zone.
(See Note A-2.4.2.1.(6) and (7).);

(31) in Article 2.4.2.3.,

(a) by striking out “and” at the end of Clause (a) of Sentence (1);

(b) by replacing “*air break*” in Clause (b) of Sentence (1) by “*air break*, and”;

(c) by adding the following after Clause (b) of Sentence (1):
“(c) is located in the same room or *suite*.”;

(d) by striking out “and” at the end of Clause (a) of Sentence (2);

(e) by replacing “(see A-2.4.2.1.(1)(a)(ii) and (e)(vi)).” in Clause (b) of Sentence (2) by “(see A-2.4.2.1.(1)(a)(ii) and (e)(vi)), and”;

(f) by adding the following after Clause (b) of Sentence (2):

“(c) is located in the same room or *suite*.”;

(g) by striking out “and” at the end of Clause (a) of Sentence (3);

(h) by replacing “are connected to it.” in Clause (b) of Sentence (3) by “are connected to it, and”;

(i) by adding the following after Clause (b) of Sentence (3):

“(c) is located in the same room or *suite*.”;

(32) by adding the following after Article 2.4.2.3.:

“2.4.2.4. Toilet Wall Supports

(1) Toilet wall supports shall be fixed to the structural elements of the building to prevent stress from being transmitted to the plumbing system.”;

(33) in Article 2.4.3.5.,

(a) by replacing the title “**Macerating Toilet Systems**” by “**Macerating Toilets and Macerating Systems**”;

(b) by replacing “macerating toilet system shall only be installed” in Sentence (1) by “macerating toilet or macerating system shall only be installed”;

(34) in Article 2.4.3.6., by replacing “that connects the sump well to the *drainage system*” in Clause (b) of Sentence (1) by “that connects the pit to the sump well”;

(35) by adding the following after Article 2.4.3.6.:

“2.4.3.7. Retention Pit

(See Note A-2.4.3.7.)

(1) A retention pit shall be made in one piece, be leakproof and smooth inside. Its length shall not be less than 600 mm and its minimum width shall not be less than 450 mm, the length being taken in the direction of its *fixture drain*. A round retention pit shall be not less than 560 mm in *size*.

(2) The *fixture drain* of the retention pit shall be not less than 3 inches in *size* and be protected by a reversed sanitary T fitting with a *cleanout* at the end or by a running *trap* with *cleanout*. The *fixture drain* shall be 4 inches in *size* if the retention pit receives *storm water*. Despite the foregoing, for a single-family house, the *fixture drain* may be 3 inches in *size*.

(3) Except as provided in Sentence (6), a reversed sanitary T fitting shall be located inside the retention pit and the running *trap* may be located inside or outside the retention pit. In the last case, the *trap cleanout* shall be extended to the floor level. The retention pit shall have a running *trap* where it is connected to an oil *interceptor*.

(4) The lower end of the reversed sanitary T fitting shall be placed 150 mm or more from the bottom of the retention pit. In the case of a retention pit that receives water from a subsoil drainage pipe, the reversed sanitary T fitting shall be placed 75 mm or more from the bottom of the retention pit. For a running *trap*, the upper end of the *trap* shall be placed not less than 300 mm from the bottom of the retention pit.

(5) The retention pit shall be covered, at the floor or ground level, by a cover designed to withstand the intended loads.

(6) The *fixture drain* of a retention pit exposed to frost shall have a *trap* inside the *building*, unless it drains into another retention pit that is not exposed.

(7) The *fixture drain* of a retention pit shall be directly connected to the *drainage system* and drain into it by gravity or in the manner described in Article 2.4.6.3.

(8) The invert of a discharge pipe connected to a retention pit shall be higher than the invert of the *fixture drain*.

(9) Except as provided in Sentence (2), a retention pit shall have a *fixture drain* 3 inches in *size* for a draining area not more than 370 m². For a *fixture drain* more than 3 inches in *size*, the drained area may be increased by 280 m² per additional inch.

(10) The requirements of Article 2.5.1.1.(3)(c) do not apply to a retention pit used as a floor drain.

(11) Retention pits to which a *subsoil drainage pipe* is connected shall have

(a) an air-tight cover, and

(b) a *vent pipe* at least 1 1/2 inches in *size* if the content of the retention pit is pumped.”;

(36) in Article 2.4.4.1., by adding the following after Sentence (1):

“(2) Every beauty parlour lavatory shall be equipped with a hair *interceptor*.

(3) Every *fixture* that can receive dental amalgam waste shall have an amalgam *interceptor*.”;

(37) by replacing Article 2.4.5.3. by the following:

“2.4.5.3. Connection of Subsoil Drainage Pipe to a Drainage System

(1) Where a *subsoil drainage pipe* is connected to a *drainage system*, the connection shall be made on the upstream side of a *trap* with a *cleanout*, a trapped sump or a retention pit (see Note A-2.4.5.3.(1)).”;

(38) by replacing Article 2.4.5.5. by the following:

“2.4.5.5. Trap seals

(1) Provision shall be made for maintaining the *trap* seal of a floor drain by

- (a) the use of a *trap* seal primer,
- (b) using the drain as a receptacle for an *indirectly connected* drinking fountain,
- (c) using a floor drain trap seal, or
- (d) other equally effective means.

(See Note A-2.4.5.5.(1).)

(2) Water from the *trap* seal of a floor drain in a *dwelling unit* need not be maintained by a *trap* seal primer.

(See Note A-2.4.5.5.(2).);

(39) in Article 2.4.6.3., by adding the following after Sentence (7):

“(8) Every sump or receiving tank to which a *subsoil drainage pipe* is connected shall have

- (a) an air tight cover, and
- (b) a *vent pipe* at least 1 1/2 inches in *size* if the sump or tank is pumped.”;

(40) in Article 2.4.6.4.,

(a) by replacing Sentences (2) and (3) by the following:

“(2) A *backwater valve* may be installed in a *building drain* provided that

- (a) it is a “normally open” design, and
- (b) it does not serve more than one *dwelling unit*.

(3) Except as provided in Sentences (4) to (6), where a *fixture*, a retention pit, a sump or running *trap* is located below the overflow level of the adjoining street or private sewage disposal system, a gate valve or a *backwater valve* shall be installed on every *drain* connected to a *building drain* or a *branch*.”;

(b) by replacing Sentence (6) by the following:

“(6) The installation of a gate valve or a *backwater valve* covered by Sentence (3) is not required if the building drain is protected from backflows in accordance with Sentence (2).”;

(41) in Article 2.4.7.1., by adding the following after Sentence (11):

“(12) In a separate system, a *storm building drain* shall be located to the left of the *sanitary building drain*, towards the street, from the *building*.”;

(42) in Article 2.4.7.4., by replacing “*fixtures*” in Sentence (5) by “*fixture drains*”;

(43) in Article 2.4.9.3., by inserting “be not less than 2 inches in *size* and” after “the *trap* inlet shall” in Sentence (3);

(44) in Article 2.4.10.3., by replacing “a *fixture*” in Sentence (1) by “equipment”;

(45) in Article 2.4.10.4., by replacing Sentence (4) by the following:

“(4) Where the height of the parapet is more than 150 mm or exceeds the height of the adjacent wall flashing, emergency roof overflows or scuppers described in Clause (2)(c) shall be provided.”;

(46) in Article 2.5.2.1.,

(a) by replacing “Table” in Clause (a) of Sentence (1) by “Article”;

(b) by replacing clauses (d) and (e) of Sentence (1) by the following:

“(d) the *trap arms* of the water closets connected to a vertical pipe are connected downstream from all other *fixtures*,

(e) *trap arms* and *fixture drains* do not exceed 2 inches in *size* when connected to a *wet vent* that extends above more than 1 *storey*, except for connections from *emergency floor drains* in accordance with Sentence 2.5.1.1.(3).”;

(c) by replacing “Table” in Clause (f) of Sentence (1) by “Article”;

(d) by replacing clauses (j) and (k) of Sentence (1) by the following:

“(j) the portion of the *soil-or-waste stack* having a *wet vent* that extends through more than one *storey* is the same *size* from its bottom to the uppermost connection of a *fixture*,

(k) the length of the *wet vent* is not limited,

(l) it is extended as a *stack vent* or as a *continuous vent*, and

(m) *trap arms* are connected separately and directly to the *wet vent*.”;

(47) in Article 2.5.6.2., by adding the following after Sentence (3):

“(4) The plumbing *venting system* may not be used in other systems.”;

(48) in Article 2.5.6.5., by adding “except pipes 4 inches and bigger that may be of the same *size*,” at the end of Clause (a) of Sentence (6);

(49) in Article 2.5.7.3., by replacing “2.5.8.1.” in Sentence (2) by “2.5.8.1.-A”;

(50) in Article 2.5.8.1.,

(a) by replacing “Table 2.5.8.1.” in Sentence (1) by “Tables 2.5.8.1.-A and 2.5.8.1.-B”;

(b) by inserting the following before Table 2.5.8.1.:

“

Table 2.5.8.1.-A
Maximum Permitted Hydraulic Loads
Drained to a Wet Vent Serving
Fixtures on the Same Storey
 Forming Part of Sentence 2.5.8.1.(1)

<i>Size of Wet Vent for a Storey, inches</i>	<i>Maximum Hydraulic Load, fixture units</i>
1 1/4	1
1 1/2	2
2	5
3	18
4	120

”;

(c) by replacing the title of Table 2.5.8.1. by “**Table 2.5.8.1.-B**”;

(51) in Article 2.5.8.4., by adding the following after Sentence (4):

“(5) At least one *soil-or-waste stack* or vertical *soil-or-waste pipe* shall extend into a *stack vent* or into a *vent pipe* that is terminated in open air. That *soil-or-waste stack* or vertical *soil-or-waste pipe* shall have a minimum *size* of 3 inches up to the outlet on the roof.”;

(52) in Article 2.5.9.2.,

(a) by replacing “shall only be used” in Sentence (1) by “may only be installed”;

(b) by replacing “two-family dwellings undergoing renovation” in Clause (c) of Sentence (1) by “two-family dwellings during renovation work only”;

(c) by replacing “installations where connection” in Clause (d) of Sentence (1) by “*fixtures* in an existing *building* where connection”;

(53) in Article 2.6.1.1., by adding the following after Sentence (2):

“(3) In a hot *water distribution system* with a recirculation loop, the temperature of the water being recirculated shall not be less than 55 °C at any point of the system.

(4) The recirculation loop covered by Sentence (3) may be replaced by a self-regulating heat tracing system.”;

(54) in Article 2.6.1.6.,

(a) by replacing Table 2.6.1.6. in Sentence (3) by the following:

“

Table 2.6.1.6.
Water Usage per Flush Cycle
Forming Part of Sentence 2.6.1.6.(3)

<i>Fixtures</i>	Maximum Water Usage per Flush Cycle, Lpf
Water closets – dwellings	
single-flush	4.8
dual-flush	6.0/4.1
Water closets – industrial, commercial, institutional, residential other than dwellings	4.8
Urinals	1.9

”;

(b) by replacing Sentence (4) by the following:

“(4) In industrial, commercial and institutional buildings, and residential buildings other than dwellings, a maximum water usage of 6.0 Lpf shall be permitted for single-flush water closets where it can be demonstrated that a maximum water usage of 4.8 Lpf could lead to blockage given the configuration of the *drainage system* or municipal infrastructure.”;

- (55) in Article 2.6.1.7.,
- (a) in Sentence (1)
 - (i) by striking out “and” at the end of Clause (a);
 - (ii) by replacing “distribution system.” in Clause (b) by “distribution system, and”;
 - (iii) by adding the following after Clause (b):
 - “(c) that has a drain complying with the requirements of Sentence (5).”;
 - (b) by replacing Sentence (10) by the following:
 - “(10) Except as provided in Sentence (11), the drain pan shall
 - (a) be not less than 50 mm larger than the *tank* and have side walls not less than 75 mm high,
 - (b) be drained by a pipe two *sizes* larger than the relief valve discharge pipe, without being less than 1 1/4 inches, and
 - (c) have a drain that is located directly under the relief valve discharge pipe and that discharges directly to a floor drain or other acceptable location.
 - “(11) The drain pan is not required to have a *fixture drain* where the relief valve discharge pipe conforms to Sentence (5).”;
- (56) in Article 2.6.1.9., by replacing Sentence (1) by the following:
 - “(1) *Water distribution systems* shall be protected against water hammers by prefabricated water-hammer arresters (see Note A-2.6.1.9.(1)).”;
- (57) in Article 2.6.1.12., by replacing Sentence (1) by the following:
 - “(1) The temperature control device of *water heaters* shall be set so that the temperature of stored water is not less than 60°C (see Note A-2.6.1.12.(1)).
 - “(2) Drain water heat recovery units shall only be used to supply *water heaters*.”;

(58) in Article 2.6.2.1., by adding the following after Sentence (3):

“(4) In the case of *backflow preventers* that, according to CSA-B64.10, “Selection and Installation of Backflow Prevention Devices”, require testing after installation, the person testing the *backflow preventers* shall hold a certificate issued in accordance with CSA-B64.10.1, “Maintenance and Field Testing of Backflow Preventers”, by an organization or association certified by AWWA.”;

(59) in Sentence (2) of Article 2.6.2.2.,

- (a) by striking out “or” at the end of Clause (j);
- (b) by replacing “with vent.” in Clause (k) by “with vent, or”;
- (c) by adding the following after Clause (k):
 - “(l) an air space type *vacuum breaker*.”;

(60) in Article 2.6.2.4.,

- (a) by replacing Sentence (2) by the following:

“(2) Except as provided in Sentence (4), *potable water system* connections to fire sprinkler and standpipe systems shall be protected against *backflow* caused by *backsiphonage* or *back pressure* in conformance with the following Clauses:

(a) *residential partial flow-through fire sprinkler/standpipe systems* in which the pipes and fittings are constructed of *potable water system* materials shall be protected by a dual *check valve backflow preventer* conforming to

(i) CSA-B64.6.1, “Dual Check Valve, Backflow Preventers for Fire Systems (DuCF)”, or

(ii) CSA-B64.6, “Dual Check Valve” (DuC) Backflow Preventers”,

(b) *Class 1 fire sprinkler/standpipe systems* shall be protected by a single *check valve backflow preventer* or by a dual *check valve backflow preventer*, provided that the systems do not use antifreeze or other additives of any kind and that the pipes and fittings are constructed of *potable water system* materials. The *backflow preventer* shall conform to

(i) CSA-B64.9, “Single Check Valve Backflow Preventers, for Fire Protection Systems (SCVAF)”, or

(ii) CSA-B64.6, “Dual Check Valve (DuC) Backflow Preventers,”

(c) *Class 1 fire sprinkler/standpipe systems* not covered by Clause (b) as well as *Class 2* and *Class 3 fire sprinkler/standpipe systems* shall be protected by a double *check valve backflow preventer*, provided that the systems do not use antifreeze or other additives of any kind. The *backflow preventer* shall conform to

(i) CSA-B64.5.1, “Double Check Valve Backflow Preventers for Fire Protection Systems (DCVAF)”, or

(ii) CSA-B64.5, “Double Check Valve (DCVAF) Backflow Preventers”,

(d) *Class 1, Class 2* and *Class 3 fire sprinkler/standpipe systems* in which antifreeze or other additives are used shall be protected by a reduced pressure principle *backflow preventer* installed on the portion of the system that uses the additives and the balance of the system shall be protected as required by Clause (b) or (c). The *backflow preventer* shall conform to

(i) CSA-B64.4.1, “Reduced Pressure Principle Backflow Preventers for Fire Protection Systems (RPF)”, or

(ii) CSA-B64.4, “Reduced Pressure Principle (RP) Backflow Preventers”,

(e) *Class 4* and *Class 5 fire sprinkler/standpipe systems* shall be protected by a reduced pressure principle *backflow preventer* conforming to

(i) CSA-B64.4.1, “Reduced Pressure Principle Backflow Preventers for Fire Protection Systems (RPF)”, or

(ii) CSA-B64.4, “Reduced Pressure Principle (RP) Backflow Preventers”,

(f) *Class 6 fire sprinkler/standpipe systems* shall be protected by a double *check valve backflow preventer* conforming to

(i) CSA-B64.5.1, “Double Check Valve Backflow Preventers for Fire Protection Systems (DCVAF)”, or

(ii) CSA-B64.5, “Double Check Valve (DCVA) Backflow Preventers”, or

(g) where a potentially severe health hazard may be caused by *backflow*, *Class 6 fire sprinkler/standpipe systems* shall be protected by a reduced pressure principle *backflow preventer* conforming to

(i) CSA-B64.4.1, “Reduced Pressure Principle Backflow Preventers, for Fire Protection Systems (RPF)”, or

(ii) CSA-B64.4, “Reduced Pressure Principle (RP) Backflow Preventers”.

(See Note A-2.6.2.4.(2)).”;

(b) by replacing Sentence (4) by the following:

“(4) Where a reduced pressure principle *backflow preventer* is required on a *water service pipe* at a fire service connection located on the same premises as the *fire service pipe* in *Class 3, 4, 5 and 6 fire sprinkler/standpipe systems*, a reduced pressure principle *backflow preventer* shall also be required on the fire service connection and conform to

(i) CSA-B64.4.1, “Reduced Pressure Principle Backflow Preventers for Fire Protection Systems (RPF)”, or

(ii) CSA-B64.4, “Reduced Pressure Principle (RP) Backflow Preventers”.”;

(61) by adding the following after Article 2.6.2.12.:

“2.6.2.13. Personal Hygiene Devices

(1) Water closet personal hygiene devices connected to a *potable water system* shall have a *backflow preventer* conforming to CSA-B64.10, “Selection and Installation of Backflow Preventers”.”;

(62) in Article 2.6.3.2., by replacing “in Table 2.6.3.2.-A” in Sentence (2) by “in Table 2.6.3.2.-A, 2.6.3.2.-B or 2.6.3.2.-C”;

(63) in Article 2.6.3.2.,

(a) by replacing the following in Table 2.6.3.2.-A:

“

Bathtub with 3/4 inch spout	3/4	7.5	7.5	10	7.5	7.5	10
-----------------------------	-----	-----	-----	----	-----	-----	----

”

by the following

“

Bathtub with 3/4 inch spout	3/4	2.25	2.25	3	4.5	4.5	6
-----------------------------	-----	------	------	---	-----	-----	---

”;

(b) by replacing Tables 2.6.3.2.-B and 2.6.3.2.-C by the following:

Table 2.6.3.2.-B
Sizing of Water Distribution Systems
for Urinals with Direct Flush Valves

Forming Part of Sentences 2.6.3.2.(4) and 2.6.3.4.(5)

Fixture or Device	Minimum Size of Supply Pipe, inches	Private Use Hydraulic Load, fixture units			Public Use Hydraulic Load, fixture units		
		Cold	Hot	Total	Cold	Hot	Total
Urinal with direct flush valve	3/4	–	–	–	5	–	5
	1/2	2	–	2	4	–	4

Table 2.6.3.2.-C
Sizing of Water Distribution Systems
for Water Closets with Direct Flush Valves

Forming Part of Sentences 2.6.3.2.(4) and 2.6.3.4.(5)

Fixture or Device	Minimum Size of Supply Pipe, inches	Private Use Hydraulic Load, fixture units			Public Use Hydraulic Load, fixture units		
		Cold	Hot	Total	Cold	Hot	Total
Water closet with direct flush valve	1	6	–	6	10	–	10

(64) in Article 2.6.3.4.,

(a) by replacing “to Table 2.6.3.2.-A.” in Sentence (2) by “to Table 2.6.3.2.-A, 2.6.3.2.-B, 2.6.3.2.-C or 2.6.3.2.-D.”;

(b) by striking out the note at the bottom of Table 2.6.3.4.;

(65) in Article 2.6.3.5., by replacing “pipe and fitting manufacturer.” at the end of Sentence (1) by “pipe and fitting manufacturer without ever exceeding 3.0 m/s.”;

(66) in Article 2.7.3.2., by replacing “An outlet” at the beginning of Sentence (1) by “Except as provided in Sentence (2) of Article 2.7.4.1., an outlet”;

(67) in Article 2.7.4.1., by replacing Sentence (2) by the following:

“(2) Non-potable water systems shall only be used to supply

(a) water closets,

(b) urinals, or

(c) sinks in tourist establishments covered by Chapter V.1 of the Regulation respecting the quality of drinking water (chapter Q-2, r. 40).”;

(68) by replacing Table 2.8.1.1. in Article 2.8.1.1. by the following:

“

Table 2.8.1.1.
Objectives and Functional Statements Attributed
to the Acceptable Solutions in Part 2
Forming Part of Sentence 2.8.1.1.(1)

Functional Statements and Objectives⁽¹⁾	
2.1.2.1. Sanitary Drainage Systems	
(1)	[F72-OH2.1]
(2)	[F72-OH2.1]
	[F72-OP5]
2.1.2.2. Storm Drainage Systems	
(1)	[F72-OP5]
2.1.2.3. Water Distribution Systems	
(1)	[F46-OH2.2]
2.1.2.4. Separate Services	
(1)	[F71-OH2.1,OH2.3] [F70-OH2.1]
2.1.3.1. Lighting and Ventilation Requirements	
(1)	[F40-OH1.1] Applies to the requirement for ventilation.
	[F30-OS3.1] Applies to the requirement for lighting.
2.1.3.2. Accessibility	
(1)	[F40-OH2.1] [F41-OH2.4] [F71-OH2.3]
	[F82-OH2.1,OH2.2,OH2.3,OH2.4]
	[F71-OH2.3] [F81-OH2.4]
	[F81-OP5]
2.1.4.1. Structural movement	
(1)	[F23,F43-OS3.4]
	[F23-OH1.1]
	[F23-OH2.1,OH2.4]
	[F23-OH5]
	[F43-OH2.1,OH2.4]
	[F43-OH5]
[F23,F43-OP5]	
2.2.1.1. Exceptional conditions	
(1)	[F80-OH2.1,OH2.2,OH2.3,OH2.4]
	[F80-OP5]

(2)	[F80-OH2.1]
	[F80-OP5]
2.2.1.2. Restrictions on Re-Use	
(1)	[F70-OH2.2]
2.2.1.5. Withstanding Pressure	
(1)	[F20,F81-OH2.1,OH2.3] [F46-OH2.2]
	[F20-OP5]
2.2.1.6. Working Pressure of a Water Service Pipe	
(1)	[F20,F81-OH2.3]
	[F20-OP5]
2.2.2.1. Surface Requirement	
(1)	[F41-OH2.4]
2.2.2.2. Conformance to Standards	
(1)	[F80-OH2.1,OH2.4]
	[F80-OS3.1]
2.2.2.3. Showers	
(1)	[F80-OH2.1]
	[F80-OP5]
(2)	[F80-OH2.1]
	[F40-OP5]
(3)	[F45-OH2.1]
(4)	[F45-OH2.1]
2.2.2.4. Concealed Overflows	
(1)	[F41,F81-OH2.1,OH2.4]
2.2.2.5. Water Closets in Public Washrooms	
(1)	[F30-OH2.1,OH2.4]
2.2.3.1. Traps	
(1)	[F81,F40-OH1.1]
(2)	[F81-OH1.1]
	[F81-OP5]
(3)	[F81-OH2.1,OH2.3,OH2.4]
	[F81-OP5]
(4)	[F81-OH1.1]
(5)	[F81-OH1.1]
2.2.3.2. Interceptors	
(1)	[F81-OH2.1,OH2.3,OH2.4]
(2)	[F81-OH2.1,OH2.3,OH2.4] [F46-OH2.2]
(3)	[F80-OH2.1,OH2.3,OH2.4]
(4)	[F81-OH2.1]

(5)	[F80-OH2.1,OH2.3,OH2.4] [F43-OH5]
(6)	[F80-OH2.1,OH2.3,OH2.4]
2.2.3.3. Tubular Traps	
(1)	[F82-OH2.1,OH2.4]
	[F82-OP5]
2.2.4.1. T and Cross Fittings	
(1)	[F81-OH2.1,OH2.4]
(2)	[F81-OH2.1,OH2.4]
2.2.4.2. Sanitary T Fittings	
(1)	[F81-OH2.1,OH2.4]
(2)	[F81-OH2.1,OH2.4]
	[F81-OP5]
2.2.4.3. 90° Elbows	
(1)	[F81-OH2.1,OH2.4]
(2)	[F81-OH2.1,OH2.4]
2.2.5.1. Concrete Pipe and Fittings	
(1)	[F20-OH2.1]
(2)	[F20-OH2.1]
(3)	[F20-OH2.1]
(4)	[F20-OH2.1]
(5)	[F20-OH2.1]
2.2.5.2. Vitrified Clay Pipe and Fittings	
(1)	[F20-OH2.1]
(2)	[F20-OH2.1]
(3)	[F20-OH2.1]
2.2.5.3. Polyethylene Pipe and Fittings	
(1)	[F20-OH2.1,OH2.2,OH2.3]
	[F20-OP5]
(2)	[F20-OP5]
(3)	[F20-OP5]
2.2.5.4. Polyethylene Pipe Used Underground	
(1)	[F72-OH2.1,OH2.3]
2.2.5.5. Crosslinked Polyethylene Pipe and Fittings	
(1)	[F20-OH2.2]
	[F20-OP5]

2.2.5.6. PVC Pipe and Fittings	
(1)	[F20-OH2.1,OH2.2,OH2.3]
	[F20-OP5]
(2)	[F20-OH2.1,OH2.2,OH2.3]
	[F20-OP5]
(3)	[F20-OH2.1,OH2.2,OH2.3]
	[F20-OP5]
(4)	[F20-OP5]
2.2.5.7. CPVC Pipe, Fittings and Solvent Cements	
(1)	[F20-OH2.2,OH2.3,OH2.4]
	[F20-OP5]
(2)	[F20-OP5]
2.2.5.8. Plastic Pipe, Fittings and Solvent Cement Used Underground	
(1)	[F20,F80,F81-OH2.1]
	[F20,F80,F81-OP5]
2.2.5.9. Transition Solvent Cement	
(1)	[F20,F80,F81-OH2.1,OH2.3]
(2)	[F20,F80,F81-OH2.1,OH2.3]
2.2.5.10. Plastic Pipe, Fittings and Solvent Cement Used in Buildings	
(1)	[F20,F80,F81-OH2.1,OH2.3]
2.2.5.11. Polyethylene/Aluminum/Polyethylene Composite Pipe and Fittings	
(1)	[F20,F80,F81-OH2.1,OH2.2,OH2.3]
	[F20-OP5]
(2)	[F20-OP5]
	[F20-OH2.1,OH2.2,OH2.3]
(3)	[F20-OP5]
	[F20-OH2.1,OH2.2,OH2.3]
(4)	[F20-OP5]
	[F20-OH2.1,OH2.2,OH2.3]
2.2.5.12. Crosslinked Polyethylene/Aluminum/Crosslinked Polyethylene Composter Pressure Pipe and Fittings	
(1)	[F20-OH2.1,OH2.2,OH2.3]
	[F20-OP5]
2.2.5.13. Polypropylene Pipe and Fittings	
(1)	[F20-OH2.1,OH2.2,OH2.3]
	[F20-OP5]

2.2.5.14. Better Heat Resistance Polyethylene Pipe and Fittings	
(1)	[F20,F70,F80-OH2.2]
	[F20F70,F80-OP5]
2.2.6.1. Cast-Iron Drainage and Vent Pipe and Fittings	
(1)	[F20-OH2.1,OH2.3]
(2)	[F20-OH2.2]
(3)	[F20-OH2.1,OH2.3]
2.2.6.2. Maintenance Holes and Catch Basins	
(1)	[F81-OH1.1]
	[F20-OS3.1]
2.2.6.3. Treaded Cast-Iron Drainage Fittings	
(1)	[F20-OH2.1,OH2.3]
(2)	[F20-OP5]
2.2.6.4. Cast-Iron Water Pipes	
(1)	[F20-OP5]
	[F20-OH2.1,OH2.2,OH2.3]
(2)	[F80-OH2.2]
(3)	[F20-OP5]
(4)	[F20-OP5]
2.2.6.5. Screwed Cast-Iron Water Fittings	
(1)	[F20-OP5]
(2)	[F80-OH2.2]
(3)	[F81-OH2.1,OH2.3]
2.2.6.6. Screwed Malleable Iron Water Fittings	
(1)	[F81-OP5]
(2)	[F80-OH2.2]
(3)	[F81-OH2.1,OH2.3]
2.2.6.7. Steel Pipe	
(1)	[F80-OH2.1,OH2.3] [F46-OH2.2]
(3)	[F46-OH2.2]
(4)	[F80-OH2.1,OH2.3]
	[F80-OP5]
2.2.6.8. Corrugated Steel Pipe and Couplings	
(1)	[F80-OP5]
(2)	[F81-OP5]
(3)	[F81-OP5]
2.2.6.9. Sheet Metal Leaders	
(1)	[F80-OP5]

2.2.6.10. Stainless Steel Pipe	
(1)	[F80-OH2.1] Applies to <i>drainage systems</i> and <i>venting systems</i> . [F46,F80-OH2.2] Applies to <i>water systems</i> .
	[F80-OP5]
(2)	[F80-OH2.1] Applies to <i>drainage systems</i> and <i>venting systems</i> . [F46,F80-OH2.2] Applies to <i>water systems</i> .
	[F80-OP5]
2.2.6.11. Stainless Steel Butt Weld Pipe Fittings	
(1)	[F80-OH2.1] Applies to <i>drainage systems</i> and <i>venting systems</i> . [F46,F80-OH2.2] Applies to <i>water systems</i> .
	[F80-OP5]
(2)	[F80-OH2.1] Applies to <i>drainage systems</i> and <i>venting systems</i> . [F46,F80-OH2.2] Applies to <i>water systems</i> .
	[F80-OP5]
2.2.6.12. Stainless Steel Pipe Flanges	
(1)	[F80-OH2.1] Applies to <i>drainage systems</i> and <i>venting systems</i> . [F46,F80-OH2.2] Applies to <i>water systems</i> .
	[F80-OP5]
(2)	[F80-OH2.1] Applies to <i>drainage systems</i> and <i>venting systems</i> . [F46,F80-OH2.2] Applies to <i>water systems</i> .
	[F80-OP5]
2.2.6.13. Stainless Steel Threaded Fittings	
(1)	[F80-OH2.1] Applies to <i>drainage systems</i> and <i>venting systems</i> . [F46,F80-OH2.2] Applies to <i>water systems</i> .
	[F20-OP5]
(2)	[F80-OH2.1] Applies to <i>drainage systems</i> and <i>venting systems</i> . [F46,F80-OH2.2] Applies to <i>water systems</i> .
	[F20-OP5]
2.2.6.14. Stainless Steel Tube	
(1)	[F46-OH2.2]
	[F80-OP5]
(2)	[F46-OH2.2]
	[F80-OP5]
2.2.6.15. Stainless Steel Pipe and Tube	
(1)	[F80-OH2.1,OH2.2,OH2.3]
2.2.7.1. Copper And Brass Pipe	
(1)	[F80-OH2.1,OH2.3] Applies to <i>drainage systems</i> and <i>venting systems</i> . [F46-OH2.2] Applies to <i>water systems</i> .
	[F80-OP5]
(2)	[F80-OH2.1,OH2.3] Applies to <i>drainage systems</i> and <i>venting systems</i> . [F46-OH2.2] Applies to <i>water systems</i> .
	[F80-OP5]

2.2.7.2. Brass or Bronze Pipe Flanges and Flanged Fittings	
(1)	[F80-OH2.1,OH2.3] Applies to <i>drainage systems</i> and <i>venting systems</i> . [F46-OH2.2] Applies to <i>water systems</i> .
	[F80-OP5]
2.2.7.3. Brass or Bronze Threaded Water Fittings	
(1)	[F80-OP5]
(2)	[F80-OH2.1,OH2.3]
2.2.7.4. Copper Tube	
(1)	[F80-OH2.1,OH2.3] Applies to <i>drainage systems</i> and <i>venting systems</i> . [F46-OH2.2] Applies to <i>water systems</i> .
	[F80-OP5]
(2)	[F80-OH2.1,OH2.2,OH2.3]
(3)	[F80-OH2.1,OH2.4]
2.2.7.5. Solder-Joint Drainage Fittings	
(1)	[F80-OH2.1,OH2.4]
(2)	[F20-OP5]
2.2.7.6. Solder-Joint Water Fittings	
(1)	[F20-OP5]
(2)	[F20-OP5]
2.2.7.7. Flared-Joint Fittings for Copper Water Systems	
(1)	[F20-OP5]
(2)	[F20-OP5]
2.2.7.8. Lead Waste Pipe and Fittings	
(1)	[F46,F20-OH2.2,OH2.3]
(2)	[F81-OH2.1,OH2.3,OH2.4]
2.2.7.9. Quick Connection Push-Fit Fittings	
(1)	[F46-OH2.2]
	[F80-OP5]
2.2.8.1. Pipes and Fittings	
(1)	[F80,F81-OH2.1]
	[F80,F81-OS3.2,OS3.4]
2.2.9.1. Cement Mortar	
(1)	[F80-OP5]
	[F80-OH2.1,OH2.3]
2.2.9.2. Solders and Fluxes	
(1)	[F80-OP5]
	[F80-OH2.1,OH2.3]
(2)	[F46-OH2.2]
(3)	[F80-OH2.1,OH2.3]
(4)	[F80-OH2.1,OH2.3]

2.2.10.1. Brass Floor Flanges	
(1)	[F80-OH2.1]
2.2.10.2. Screws, Bolts, Nuts and Washers	
(1)	[F80-OH2.1,OH2.3]
2.2.10.3. Cleanout Fittings	
(1)	[F80-OH2.1,OH2.3] Applies to <i>drainage systems</i> . [F46-OH2.2] Applies to <i>water systems</i> .
(2)	[F80-OH2.1]
2.2.10.4. Mechanical Couplings	
(1)	[F80-OP5]
(2)	[F80-OH2.1,OH2.3]
2.2.10.5. Saddle Hubs	
(1)	[F81-OH2.1,OH2.3]
	[F81-OP5]
2.2.10.6. Supply and Waste Fittings	
(1)	[F80-OP5]
(2)	[F131-OE1.2]
(3)	[F30-OS3.1] [F31-OS3.2]
(4)	[F131-OE1.2]
(5)	[F131-OE1.2]
(6)	[F80-OH2.1,OH2.3]
2.2.10.7. Water Temperature Control	
(1)	[F30,F31,F80-OS3.1,OS3.2]
(2)	[F31,F80-OS3.2]
(3)	[F30,F31,F80-OS3.1,OS3.2]
(4)	[F30,F31,F80-OS3.1,OS3.2]
(5)	[F31,F80-OS3.2]
(6)	[F31-OS3.2]
2.2.10.8. Direct Flush Valves	
(1)	(c) and (d) [F80-OH2.1] [F81-OH2.4]
	(a) and (b) [F80,F81-OP5]
2.2.10.9. Drinking Fountain Bubblers	
(1)	[F40,F46-OH2.4]
(2)	[F41,F46-OH2.2]
(3)	[F41,F46-OH2.2]
2.2.10.10. Back-Siphonage Preventers and Backflow Preventers	
(1)	[F46-OH2.2]
(2)	[F46-OH2.2]

2.2.10.11. Relief Valves	
(1)	[F31-OS3.2]
	[F31-OP5]
2.2.10.12. Reducing Valves	
(1)	[F81-OP5]
2.2.10.13. Hot Water	
(1)	[F46-OH2.2]
	[F80,F81-OP5]
	[F31,F81-OS3.2]
	[F43-OS3.4]
2.2.10.14. Vent Pipe Flashing	
(1)	[F80,F81-OP5]
(2)	[F80,F81-OP5]
2.2.10.15. Water Hammer Arresters	
(1)	[F20,F80-OP5]
2.2.10.16. Air Admittance Valves	
(1)	[F81-OH1.1]
2.2.10.17. Water Treatment Systems	
(1)	[F70,F81,F46-OH2.1,OH2.2,OH2.3]
(2)	[F70,F81,F46-OH2.1,OH2.2,OH2.3]
(3)	[F70,F81,F46-OH2.1,OH2.2,OH2.3]
(4)	[F70,F81,F46-OH2.1,OH2.2,OH2.3]
(5)	[F70,F81,F46-OH2.1,OH2.2,OH2.3]
2.2.10.18. Backwater Valves	
(1)	[F80-OH2.1]
2.2.10.19. Floor Drains and Shower Drains	
(1)	[F80-OH2.1,OH2.4]
2.2.10.20. Roof Drains	
(1)	[F80-OP5]
	[F80-OS2.1]
2.2.10.21 Trap Seal Primer Devices	
(1)	[F80-OH1.1]
2.2.10.22. Pipe Supports and Hangers	
(1)	[F20-OH2.1]
	[F20-OS3.1]
	[F80-OP5]
2.2.10.23. Floor Drain Trap Seals	
(1)	[F80,F82-OH1.1]
2.2.10.24. Expansion Tanks	
(1)	[F80,F82-OH1.1]
2.2.10.25. Heat Recovery Unit	
(1)	[F80,F82-OH1.1]
2.3.2.1. Caulked Lead Drainage Joints	
(1)	[F80-OH2.1,OH2.3]

(2)	[F80-OH2.1]
(3)	[F81-OH2.1]
(4)	[F81-OH2.1]
2.3.2.2. Wiped Joints	
(1)	[F80,F81-OH2.1]
	[F80,F81-OP5]
(2)	[F80,F81-OH2.1,OH2.2,OH2.3]
(3)	[F80,F81-OH2.1,OH2.2,OH2.3]
2.3.2.3. Screwed Joints	
(1)	[F80,F81-OH2.1,OH2.2,OH2.3]
(2)	[F70-OH2.2]
2.3.2.4. Soldered Joints	
(1)	[F20,F81-OH2.1,OH2.2,OH2.3]
2.3.2.5. Flared Joints	
(1)	[F20,F81-OH2.1,OH2.2,OH2.3]
	[F20,F81-OP5]
(2)	[F20,F81-OH2.1,OH2.2,OH2.3]
	[F20,F81-OP5]
2.3.2.6. Mechanical Joints	
(1)	[F20-OH2.1,OH2.2,OH2.3]
	[F20-OP5]
2.3.2.7. Cold-Caulked Joints	
(1)	[F20,F81-OH1.1] Applies to bell and spigot joints in <i>venting systems</i> .
	[F20,F81-OH2.1,OH2.3] Applies to bell and spigot joints in <i>drainage systems or venting systems</i> .
	[F20,F81-OP5]
(2)	[F20,F81-OH1.1]
	[F20,F81-OP5]
	[F20,F81-OH2.1,OH2.2,OH2.3]
(3)	[F20-OH2.1,OH2.3]
2.3.2.8. Stainless Steel Welded Joints	
(1)	[F20,F81-OH2.1,OH2.2,OH2.3]
(2)	[F20,F81-OH2.1,OH2.2,OH2.3]
2.3.3.1. Drilled and Tapped Joints	
(1)	[F81-OH1.1]
	[F20,F81-OH2.2,OH2.3]
2.3.3.2. Extracted Tees	
(1)	[F81-OH2.1,OH2.3]
	[F20-OP5]

2.3.3.3. Prohibition of Welding of Pipes and Fittings	
(1)	[F20-OH1.1]
	[F20-OH2.1,OH2.2,OH2.3]
(2)	[F80-OH2.2]
	[F80-OP5]
2.3.3.4. Unions and Slip Joints	
(1)	[F81-OH1.1]
	[F81-OH2.1,OH2.3]
(2)	[F81-OH1.1]
	[F81-OH2.1,OH2.3]
2.3.3.5. Increaser or Reducer	
(1)	[F81-OH1.1]
	[F70,F80-OH2.2]
2.3.3.6. Dissimilar Materials	
(1)	[F80-OH1.1]
	[F80-OP5]
	[F80-OH2.1]
2.3.3.7. Connection of Roof Drain to Leader	
(1)	[F21,F81-OP5]
2.3.3.8. Connection of Floor Outlet Fixtures	
(1)	[F80-OH2.1,OH2.3]
(2)	[F80-OH2.1]
(4)	[F20-OH2.1]
	[F20-OS3.1]
(5)	[F81-OH2.1]
(6)	[F21-OH2.1]
2.3.3.9. Expansion and Contraction	
(1)	[F21-OH1.1]
	[F21-OH2.1]
	[F21-OP5]
2.3.3.10. Copper Tube	
(1)	[F20-OH1.1]
	[F20-OP5]
2.3.3.11. Indirect Connections	
(1)	[F81-OH2.2,OH2.4]
(2)	[F81-OH2.2,OH2.4]
2.3.3.12. Copper Joints Used Underground	
(1)	[F20,F80-OP5]
(2)	[F20,F80-OP5]

2.3.4.1. Capability of Support	
(1)	[F20-OH2.1,OH2.4]
	[F20-OS3.1]
	[F20-OP5]
(2)	[F20-OH2.1,OH2.3]
	[F20-OS3.1]
(3)	[F20-OS3.1]
	[F20-OH2.1,OH2.3]
2.3.4.2. Independence of Support	
(1)	[F20-OS3.1]
	[F20-OH2.1,OH2.3]
	[F20-OP5]
2.3.4.3. Insulation of Support	
(1)	[F80-OH2.1,OH2.3]
	[F80-OS3.1]
	[F80-OP5]
(2)	[F80-OH2.1,OH2.3]
	[F80-OS3.1]
	[F80-OP5]
2.3.4.4. Support for Vertical Piping	
(1)	[F20-OH2.1]
	[F20-OS3.1]
(2)	[F20-OH2.1]
	[F20-OS3.1]
	[F20-OP5]
2.3.4.5. Support for Horizontal Piping	
(1)	[F20-OS3.1]
	[F20-OH2.1,OH2.3]
	[F20-OP5]
(2)	[F20-OS3.1]
	[F20-OH2.1]
	[F20-OP5]
(3)	[F20-OP5]
	[F20,F81-OS3.1]
	[F20-OH2.1]
(4)	[F81-OP5]
	[F81-OS3.1]

(5)	[F20,F21-OP5]
	[F20-OS3.1]
	[F20-OH2.1]
(6)	[F20-OP5]
	[F20-OS3.1]
	[F20-OH2.1]
2.3.4.6. Support for Underground Horizontal Piping	
(1)	[F20-OP5]
	[F81-OH2.1]
2.3.4.7. Support for Vent Pipe above a Roof	
(1)	[F81-OS3.1]
	[F81-OP5]
2.3.5.1. Pipe Protection	
(1)	a) [F81-OP5]
	[F81-OH2.1,OH2.3]
2.3.5.2. Isolation from Loads	
(1)	[F81-OH2.1,OH2.3]
	[F81-OP5]
2.3.5.3. Protection from Frost	
(1)	[F81-OP5]
	[F81-OH2.1,OH2.3]
2.3.5.4. Protection from Mechanical Damage	
(1)	[F81-OH2.1,OH2.3]
	[F81-OP5]
(2)	[F81-OH2.1,OH2.3]
	[F81-OP5]
(3)	[F81-OH2.1,OH2.3]
	[F81-OP5]
2.3.5.5. Protection from Condensation	
(1)	[F81-OP5]
2.3.6.1. Tests and Inspection of Drainage or Venting Systems	
(1)	[F81-OH2.1,OH2.3] Applies to <i>drainage systems</i> .
	[F81-OH1.1] Applies to <i>venting systems</i> .
(2)	[F81-OH1.1] Applies to <i>venting systems</i> .
	[F81-OH2.1,OH2.3] Applies to <i>drainage systems</i> .
(3)	[F81-OH1.1]
	[F81-OH2.1,OH2.3]
(4)	[F81-OH1.1] Applies to <i>venting systems</i> .
	[F81-OH2.1,OH2.3] Applies to <i>drainage systems</i> .

(5)	[F81-OH2.1,OH2.3]
2.3.6.2. Tests of Pipes in Drainage Systems	
(1)	[F81-OH2.1,OH2.3]
	[F81-OP5]
(2)	[F81-OH2.1]
2.3.6.3. Tests of Venting Systems	
(1)	[F81-OH1.1]
2.3.6.4. Water Pressure Tests	
(1)	[F81-OH1.1]
	[F81-OH2.1,OH2.3]
(2)	[F81-OH1.1]
	[F81-OH2.1,OH2.3]
2.3.6.5. Air Pressure Tests	
(1)	[F81-OH1.1]
	[F81-OH2.1,OH2.3]
2.3.6.6. Final Tests	
(1)	[F81-OH1.1]
	[F81-OH2.1,OH2.3]
(2)	[F81-OH1.1]
	[F81-OH2.1,OH2.3]
2.3.6.7. Ball Tests	
(1)	[F81-OH2.1,OH2.3]
(2)	[F81-OH2.1,OH2.3]
2.3.6.8. Smoke Tests	
(1)	[F81-OH1.1]
	[F81-OH2.1,OH2.3]
2.3.7.1. Application of Tests	
(1)	[F81-OP5]
(3)	[F81-OP5]
(4)	[F81-OP5]
2.3.7.2. Pressure Tests of Potable Water Systems	
(1)	[F20-OP5]
(2)	[F20,F81-OS3.1]
2.3.7.3. Water Pressure Tests	
(1)	[F81-OP5]
(2)	[F70-OH2.2]

2.4.2.1. Connections to Sanitary Drainage Systems	
(1)	[F72-OH2.1] Applies to <i>fixtures</i> that are <i>directly connected to sanitary drainage systems</i> .
	(a) [F81-OH2.2]
	(b) [F81-OH2.2]
	(c) [F81-OH2.1]
	(d) [F81-OH2.1]
	(e) [F81-OH2.1]
(2)	[F81-OH1.1]
(3)	[F81-OH1.1]
(4)	[F81-OH1.1]
(5)	[F81-OH1.1]
(6)	[F81-OH1.1]
(7)	[F81-OH1.1]
2.4.2.2. Connection of Overflows from Rainwater Tanks	
(1)	[F81-OH2.2]
2.4.2.3. Direct Connections	
(1)	[F81-OH2.2]
(2)	[F81-OH2.1,OH2.4]
(3)	[F81-OH2.4]
2.4.2.4. Toilet Wall Supports	
(1)	[F20,F81-OH2.1,OH2.3]
2.4.3.1. Urinals	
(1)	[F81-OH2.4]
2.4.3.2. Restricted Locations of Indirect Connections and Traps	
(1)	[F81-OH2.1,OH2.4]
2.4.3.3. Equipment Restrictions Upstream of Grease Interceptors	
(1)	[F81-OH2.1]
2.4.3.4. Fixtures Located in Chemicals Storage Locations	
(1)	[F81-OS1.1]
	[F43-OH5]
2.4.3.5. Macerating Toilet Systems	
(1)	[F72-OH2.1]
2.4.3.6. Drains Serving Elevator Pits	
(1)	(a) [F62-OP5]
	(b) [F81-OH2.1]
2.4.3.7. Retention Pits	
(1)	[F60,F61-OH1.1]
(2)	[F81-OH1.1]
	[F81-OH2.1]

(3)	[F81-OH1.1]
(4)	[F81-OH1.1]
(5)	[F40-OH1.1]
	[F30-OS3.1]
(6)	[F81-OH2.1, OH2.3]
	[F81-OP5]
(7)	[F81-OH2.1, OH2.2]
	[F72-OH2.1]
(8)	[F81-OH2.1]
(9)	[F72-OH2.1]
	[F81-OS2.1]
	[F81-OP5]
(10)	[F81-OH1.1]
(11)	[F81-OH2.1]
	[F43-OH1.1]
2.4.4.1. Sewage Treatment	
(1)	[F81-OH2.1]
(2)	[F81-OH2.1]
(3)	[F81-OH2.1]
2.4.4.2. Cooling of Hot Water or Sewage	
(1)	[F81-OH2.1]
2.4.4.3. Interceptors	
(1)	[F81-OH2.1]
(2)	[F81-OS1.1]
	[F43-OH5]
(3)	[F81-OH2.1]
(4)	[F81-OH2.1]
2.4.4.4. Neutralizing and Dilution Tanks	
(1)	[F80-OS3.4]
(2)	[F43-OH5]
	[F80-OH2.1]
2.4.5.1. Traps for Sanitary Drainage Systems	
(1)	[F81-OH1.1]
(6)	[F81-OH1.1]
	[F81-OP5]
2.4.5.2. Traps for Storm Drainage Systems	
(1)	[F81-OH1.1]
(2)	[F81-OH1.1]
(3)	[F81-OP5]

2.4.5.3. Connection of Subsoil Drainage Pipe to a Sanitary Drainage System	
(1)	[F81-OH2.1]
2.4.5.4. Location and Cleanout for Building Traps	
(1)	[F81-OH2.1]
	[F81-OH1.1]
2.4.5.5. Trap Seals	
(1)	[F81-OH1.1]
(2)	[F81-OH1.1]
2.4.6.1. Separate Systems	
(1)	[F81-OH2.1]
(2)	[F81-OH2.1]
(3)	[F81-OH1.1]
2.4.6.2. Location of Soil-or-Waste Pipes	
(1)	[F81-OH2.2]
2.4.6.3. Sumps or Tanks	
(1)	[F81-OH2.1]
(2)	[F81-OH2.1] Applies to the watertightness of sumps or tanks.
	[F81-OH1.1]
(3)	[F81-OH2.1]
(4)	[F81-OH2.1]
(5)	[F81-OH2.1]
(6)	[F81-OH2.1]
(7)	[F81-OH2.1]
(8)	[F81-OH2.1]
	[F43-OH1.1]
2.4.6.4. Protection from Backflow	
(1)	[F81-OH2.1]
	[F81-OH1.1]
(2)	[F81-OH1.1]
	[F81-OH2.1]
(3)	[F81-OH2.1]
(6)	[F81-OH2.1]
2.4.6.5. Mobile Home Sewer Service	
(1)	[F81-OH2.1]
2.4.7.1. Cleanouts for Drainage Systems	
(1)	[F81-OH2.1]
(2)	[F81-OH2.1]
(3)	[F81-OH2.1]
(4)	[F81-OH2.1]

(5)	[F81-OH2.1]
(6)	[F81-OH2.1]
(7)	[F81-OH2.1]
(8)	[F81-OH2.1]
(9)	[F81-OH2.1]
(10)	[F82-OH2.1]
	[F82-OP5]
(11)	[F81-OH2.1]
	[F81-OP5]
(12)	[F62-OH1.1]
	[F72-OH2.3]
2.4.7.2. Size and Spacing of Cleanouts	
(1)	[F81-OH2.1]
(2)	[F81-OH2.1]
(3)	[F81-OH2.1]
(4)	[F81-OH2.1]
(5)	[F81-OH2.1]
(6)	[F81-OH2.1]
2.4.7.3. Manholes	
(1)	[F20-OS3.1]
(2)	(a) and (c) [F81-OH1.1]
	(a) and (c) [F81-OS1.1]
	b) [F20-OS3.1]
(3)	[F30-OS3.1]
(4)	[F81-OH2.1]
2.4.7.4. Location of Cleanouts	
(1)	[F81-OH2.1]
(2)	(a) [F81-OS3.1]
	(b) [F81-OH2.1]
(3)	[F81-OH2.1]
(4)	[F81-OH2.1] Applies to drainage piping.
	[F81-OH1.1] Applies to vent piping.
(5)	[F43-OH2.1]
2.4.8.1. Minimum Slope	
(1)	[F81-OH2.1]
2.4.8.2. Length of Fixture Outlet Pipes	
(1)	[F81-OH1.1]

2.4.9.1. No Reduction in Size	
(1)	[F81-OH2.1]
	[F81-OH1.1]
2.4.9.2. Serving Water Closets	
(1)	[F81-OH2.1]
(2)	[F81-OH2.1]
(3)	[F81-OH2.1]
(4)	[F81-OH2.1]
2.4.9.3. Size of Fixture Outlet Pipes	
(1)	[F81-OH2.1]
(2)	[F81-OH2.1]
(3)	[F81-OP5]
	[F81-OH1.1]
2.4.9.4. Size of Building Drain and Building Sewer	
(1)	[F81-OH2.1]
2.4.9.5. Offset in Leaders	
(1)	[F81-OH2.1,OH2.3]
(2)	[F81-OH2.1]
2.4.10.1. Total Load on a Pipe	
(1)	[F81-OH2.1]
2.4.10.2. Hydraulic Load on a Pipe	
(2)	[F81-OH2.1]
2.4.10.3. Hydraulic Loads from Fixtures with a Continuous Flow	
(1)	[F81-OH2.1]
(2)	[F81-OH2.1]
2.4.10.4. Hydraulic Loads from Roofs or Paved Surfaces	
(1)	[F81-OP5]
	[F20,F81-OS2.1]
(2)	[F20,F81-OP5]
	(a), (d) and (e) [F41,F81-OH2.4]
	(b) and (c) [F20,F81-OS2.1]
(3)	[F20,F81-OP5]
	[F20,F81-OS2.1]
(4)	[F20,F81-OP5]
	[F20,F81-OS2.1]
2.4.10.5. Conversion of Fixture Units to Litres	
(1)	[F81-OH2.1]

2.4.10.6. Hydraulic Loads to Soil-or-Waste Pipes	
(1)	[F72-OH2.1,OH2.3]
(2)	[F72-OH2.1,OH2.3]
2.4.10.7. Hydraulic Loads on Branches	
(1)	[F72-OH2.1,OH2.3]
2.4.10.8. Hydraulic Loads on Sanitary Building Drains or Sewers	
(1)	[F81-OH2.1,OH2.3]
2.4.10.9. Hydraulic Loads on Storm or Combined Building Drains or Sewers	
(1)	[F81-OH2.1,OH2.3]
2.4.10.10. Hydraulic Loads to Roof Gutters	
(1)	[F81-OP5]
2.4.10.11. Hydraulic Loads on Leaders	
(1)	[F81-OP5]
2.4.10.12. Hydraulic Loads from Fixtures with a Semi-continuous Flow	
(1)	[F81-OP5]
2.4.10.13. Design of Storm Sewers	
(1)	[F81-OH2.1]
2.5.1.1. Venting for Traps	
(1)	[F81-OH1.1]
(2)	[F81-OH1.1]
2.5.2.1. Wet Venting	
(1)	[F81-OH1.1]
2.5.3.1. Circuit Venting	
(1)	[F40,F81-OH1.1]
(2)	[F40,F81-OH1.1]
(3)	[F40,F81-OH1.1]
(4)	[F40,F81-OH1.1]
(5)	[F40,F81-OH1.1]
(6)	[F40,F81-OH1.1]
(7)	[F40,F81-OH1.1]
(8)	[F40,F81-OH1.1]
(9)	[F40,F81-OH1.1]
(10)	[F40,F81-OH1.1]
(11)	[F40,F81-OH1.1]
2.5.4.1. Stack Vents	
(1)	[F40,F81-OH1.1]

2.5.4.2. Vent Stacks	
(1)	[F40,F81-OH1.1]
(3)	[F40,F81-OH1.1]
(4)	[F40,F81-OH1.1]
2.5.4.3. Yoke Vents	
(1)	[F40,F81-OH1.1]
(2)	[F40,F81-OH1.1]
(3)	[F40,F81-OH1.1]
(4)	[F40,F81-OH1.1]
2.5.4.4. Offset Relief Vents	
(1)	[F40,F81-OH1.1]
2.5.4.5. Fixtures Draining into Vent Pipes	
(1)	[F40,F81-OH1.1]
2.5.5.1. Venting of Sewage Sumps	
(1)	[F40,F81-OH1.1]
2.5.5.2. Venting of Oil Interceptors	
(1)	[F40,F81-OS1.1]
	[F72,F81-OH2.1,OH2.3]
	[F40,F81-OH1.1]
(2)	[F40,F81-OS1.1]
	[F40,F81-OH1.1]
(3)	[F40,F81-OS1.1]
(4)	[F40,F81-OS1.1]
(5)	[F40,F81-OS1.1]
2.5.5.3. Venting of Drain Piping and Dilution Tanks for Corrosive Waste	
(1)	[F80,F81-OS3.4]
2.5.5.4. Fresh Air Inlets	
(1)	[F81-OH1.1]
2.5.5.5. Provision for Future Installations	
(1)	[F81-OH1.1] Applies to <i>venting systems</i> .
	[F81-OH2.1,OH2.3] Applies to <i>drainage systems</i> .
(2)	[F40,F81-OH1.1]
2.5.6.1. Drainage of Vent Pipes	
(1)	[F81-OH1.1]
	[F81-OS1.1]

2.5.6.2. Vent Pipe Connections	
(1)	[F81-OH1.1]
(2)	[F81-OH1.1]
(3)	[F40,F81-OH1.1]
(4)	[F43-OS3.4,OH1.1]
2.5.6.3. Location of Vent Pipes	
(1)	[F81-OH1.1]
(2)	[F81-OH2.1,OH2.3]
(3)	[F81-OH1.1]
(4)	[F40,F81-OH1.1]
2.5.6.4. Connection of Vents above Fixtures Served	
(1)	[F81-OH1.1]
(2)	[F81-OH1.1]
2.5.6.5. Terminals	
(1)	[F81-OH1.1]
(2)	[F81-OH1.1]
(3)	[F81-OH1.1]
(4)	[F81-OH1.1]
(5)	[F81-OH1.1]
(6)	[F81-OH1.1]
2.5.7.1. General	
(1)	[F81-OH1.1]
2.5.7.2. Size Restriction	
(1)	[F81-OH1.1]
(2)	[F81-OH1.1]
2.5.7.3. Additional Circuit Vents and Relief Vents	
(1)	[F81-OH1.1]
(2)	[F81-OH1.1]
2.5.7.4. Offset Relief Vents	
(1)	[F81-OH1.1]
2.5.7.5. Yoke Vents	
(1)	[F81-OH1.1]
2.5.7.6. Vent Pipes for Manholes	
(1)	[F81-OH2.1]
2.5.7.7. Vents for Sewage Sumps, Dilution Tanks and Macerating Toilet Systems	
(1)	[F81-OH2.1]
(2)	[F81-OH2.1]
(3)	[F81-OH1.1]

2.5.8.1. Hydraulic Loads Draining to Wet Vents	
(1)	[F81-OH1.1]
2.5.8.2. Individual Vents and Dual Vents	
(1)	[F81-OH1.1]
2.5.8.3. Branch Vents, Vent Headers, Continuous Vents and Circuit Vents	
(1)	[F81-OH1.1]
2.5.8.4. Vent Stacks or Stack Vents	
(3)	[F81-OH1.1]
(4)	[F81-OH1.1]
2.5.9.2. Air Admittance Valves	
(1)	[F40,F81-OH1.1]
(2)	[F40,F81-OH1.1]
2.5.9.3. Installation Conditions	
(1)	[F40,F81-OH1.1]
(2)	[F40,F81-OH1.1]
(3)	[F40,F81-OH1.1]
(4)	[F40,F81-OH1.1]
(5)	[F40,F81-OH1.1]
2.6.1.1. Design	
(1)	[F31-OS3.2]
(2)	[F71-OH2.3]
(3)	[F40-OH1.1]
(4)	[F40-OH1.1]
2.6.1.2. Drainage	
(1)	[F81-OP5]
2.6.1.3. Shut-off Valves	
(1)	[F81-OP5]
(2)	[F81-OP5]
(3)	[F81-OP5]
(4)	[F81-OP5]
(5)	[F70,F72-OH2.1,OH2.3]
(6)	[F70,F72-OH2.1,OH2.3]
(7)	[F70,F81-OH2.1,OH2.3]
2.6.1.4. Protection for Exterior Water Supply	
(1)	[F81-OP5]
2.6.1.5. Check Valves	
(1)	[F20,F81-OP5]

2.6.1.6. Flushing Devices	
(1)	[F72-OH2.1]
(2)	[F72-OH2.1]
(3)	[F130-OE1.2]
(4)	[F81-OH2.1]
(5)	[F130-OE1.2]
2.6.1.7. Relief Valves	
(1)	[F31,F81-OS3.2]
(2)	[F81-OS3.1,OS3.2]
(4)	(a) [F31-OS3.2] [F81-OS1.1] (b) [F81-OS3.1,OS3.2]
(5)	[F31-OS3.2]
	(b) [F81-OH2.2] Applies to the size of <i>air breaks</i> .
(6)	[F31-OS3.2]
(7)	[F31-OS3.2]
(8)	[F81-OS3.2]
(9)	[F81-OP5]
(10)	[F81-OP5]
2.6.1.8. Solar Domestic Hot Water Systems	
(1)	[F31-OS3.2] [F81-OS3.4]
	[F70-OH2.2]
2.6.1.9. Water Hammer	
(1)	[F20,F81-OS3.2]
	[F20,F81-OP5]
2.6.1.10. Mobile Home Water Service	
(1)	[F71,F70,F46-OH2.2,OH2.3]
2.6.1.11. Thermal Expansion	
(1)	[F20,F81,F46-OP5]
2.6.1.12. Service Water Heaters	
(1)	[F40-OS3.4]
(2)	[F30,F31-OS3.1,OS3.2] [F46-OH1.1]
2.6.2.1. Connection of Systems	
(1)	[F70,F81,F46-OH2.1,OH2.2,OH2.3]
(2)	[F70,F81,F46-OH2.1,OH2.2,OH2.3]
(3)	[F70,F81,F82-OH2.2,OH2.3]
2.6.2.2. Back-Siphonage	
(1)	[F70,F81,F46-OH2.1,OH2.2,OH2.3]
(2)	[F70,F81,F46-OH2.1,OH2.2,OH2.3]

2.6.2.3. Backflow Caused by Back Pressure	
(1)	[F70,F81,F46-OH2.1,OH2.2,OH2.3]
(2)	[F70,F81,F46-OH2.1,OH2.2,OH2.3]
(3)	[F70,F81,F46-OH2.1,OH2.2,OH2.3]
2.6.2.4. Backflow from Fire Protection Systems	
(2)	[F46,F70,F81-OH2.1,OH2.2,OH2.3]
(3)	[F46,F70,F81-OH2.1,OH2.2,OH2.3]
(4)	[F46,F70,F81-OH2.1,OH2.2,OH2.3]
2.6.2.5. Separation of Water Supply Systems	
(1)	[F70,F81,F46-OH2.1,OH2.2,OH2.3]
2.6.2.6. Premise Isolation	
(1)	[F70,F81,F82-OH2.1,OH2.2,OH2.3]
2.6.2.7. Hose Bibb	
(1)	[F70,F81,F46-OH2.1,OH2.2,OH2.3]
2.6.2.8. Cleaning of Systems	
(1)	[F70,F81,F46-OH2.1,OH2.2,OH2.3]
2.6.2.9. Air Gap	
(1)	[F70,F81,F46-OH2.1,OH2.2,OH2.3]
(2)	[F70,F81,F46-OH2.1,OH2.2,OH2.3]
2.6.2.10. Vacuum Breakers	
(2)	[F70,F81,F46-OH2.1,OH2.2,OH2.3]
(3)	[F70,F81,F46-OH2.1,OH2.2,OH2.3]
(4)	[F70,F81,F46-OH2.1,OH2.2,OH2.3]
2.6.2.11. Tank-Type Water Closets	
(1)	[F70,F81,F46-OH2.1,OH2.2,OH2.3]
2.6.2.12. Backflow Preventers	
(1)	[F70,F81,F46-OH2.1,OH2.2,OH2.3]
2.6.2.13. Personal Hygiene Devices	
(1)	[F70,F81,F46-OH2.1,OH2.2,OH2.3]
2.6.3.1. Design, Fabrication and Installation	
(1)	[F71,F72-OH2.1,OH2.3]
(2)	[F72-OH2.1] [F70-OH2.2] [F71-OH2.3]
(3)	[F81,F81-OS1.4]
	[F70,F71-OH2.1,OH2.3]
	[F81-OP5]

2.6.3.2. Hydraulic Load	
(1)	[F71,F72-OH2.1,OH2.3]
(2)	[F71,F72-OH2.1,OH2.3]
(3)	[F71,F72-OH2.1,OH2.3]
(4)	[F81-OH2.1,OH2.2]
2.6.3.3. Static Pressure	
(1)	[F81-OS3.2]
2.6.3.4. Size	
(1)	[F71,F72-OH2.1,OH2.3]
(2)	[F71,F72-OH2.1,OH2.3]
(3)	[F71,F72-OH2.1,OH2.3]
(4)	[F81-OH2.3]
(5)	[F71,F72-OH2.1,OH2.3]
2.6.3.5. Velocity	
(1)	[F81-OH2.1,OH2.3]
	[F81-OP5]
	[F81-OS3.1]
2.7.1.1. Not Permitted	
(1)	[F46-OH2.2]
2.7.2.1. Markings Required	
(1)	[F46-OH2.2]
2.7.3.1. Pipes	
(1)	[F46-OH2.2]
2.7.3.2. Outlets	
(1)	[F46-OH2.2]
2.7.4.1. Non-potable Water Systems Design	
(1)	[F81-OH2.1]
(2)	[F82-OH2.2]

(1) See Parts 2 and 3 of Division A.

”
,

(69) by inserting, in Tables A-2.2.5., 2.2.6. and 2.2.7., after

“

PVC fittings, Schedule 80	ASTM D 2467	2.2.5.7.2.(2)	N	N	N	N	N	N	N	P ⁽⁴⁾⁽⁵⁾	P	P
---------------------------	-------------	---------------	---	---	---	---	---	---	---	---------------------	---	---

”
,

the following:

“

Pipes made of polyethylene of raised temperature resistance (PE-RT)	CSA B137.18	2.2.5.14.(1)	N	N	N	N	N	N	P ⁽⁴⁾ (5)	P ⁽⁴⁾ (5)	P	P
---	-------------	--------------	---	---	---	---	---	---	----------------------	----------------------	---	---

”.

(70) by adding the following after note A-2.2.5.13.:

“A-2.2.5.14. (1) Pipes Made of Polyethylene of Raised Temperature Resistance. It should be pointed out that CSA B137.18, “Polyethylene of Raised Temperature Resistance (PE-RT) Tubing Systems for Pressure Applications”, has specific installation requirements that shall be met.”;

(71) by replacing note A-2.2.10.7. by the following:

“A-2.2.10.7. Water Temperature Control. Hot water produced by a service water heater shall be at a minimum temperature of 60 °C to prevent the development of potentially fatal bacteria. At that temperature, water causes second degree burns to the skin in 1 to 5 seconds. Consequently, Article 2.2.10.7. provides for the installation and adjustment of valves, mixing valves and limiting devices to provide a water outlet temperature that is lower than the temperature produced by a service water heater. Compliance with that Article reduces the risk of scalding in showers and bathtubs, where severe burns occur, and reduces the risk of thermal shock that may occur in the shower and lead to falls.

Children, the elderly and persons with disabilities are particularly at risk of scald burns because they are not always able to remove themselves quickly from a situation that could lead to burns. At 49 °C, the time for a scald burn to occur on a healthy adult is nearly 10 minutes, whereas the time for a skin burn to occur on an elderly is 3 minutes, because the elderly’s skin is thinner and less vascularized. For those persons, a temperature of 43 °C provides a more adapted protection against burns because they can only occur after a number of hours of exposure.

In private seniors’ residences and care occupancies, Article 2.2.10.7. provides that the valves and thermostatic-mixing valves shall be adjusted to provide a maximum water outlet temperature at 43 °C. The installation of pressure-balanced valves is also prohibited, because those valves are sensitive to seasonal changes of the cold water temperature and require some settings per year in order not to exceed the prescribed temperature.

The water outlet temperature at other fixtures, such as lavatories, sinks, laundry trays or bidets, is not addressed by Article 2.2.10.7., but a scald risk may exist at such fixtures nonetheless.”;

(72) by replacing Figure A-2.3.3.9. in note A-2.3.3.9. by the following:

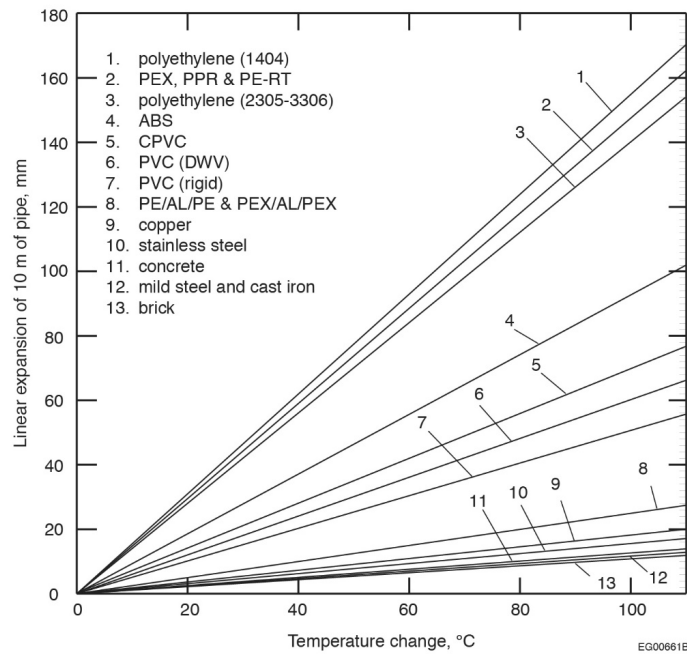

Figure A-2.3.3.9.
Linear Expansion

”;

(73) by replacing Figure A-2.4.2.1.(2) in note A-2.4.2.1.(2) by the following:

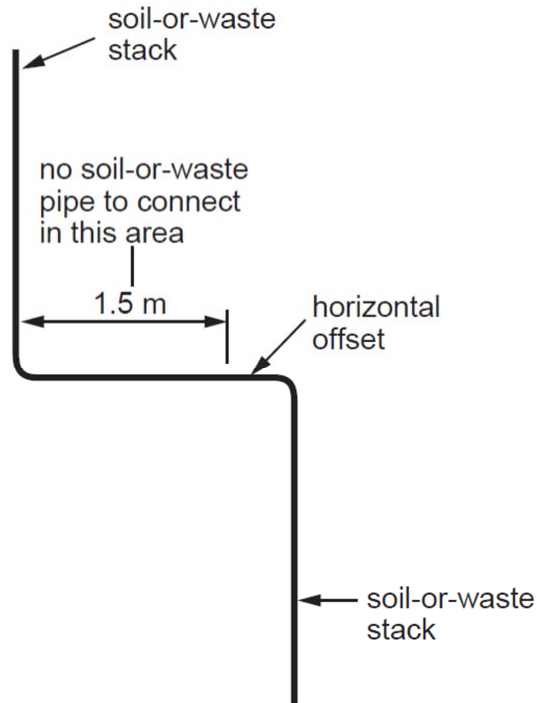

Figure A-2.4.2.1.(2)
Soil-or-Waste Pipe Connections

”
”

(74) by replacing note A-2.4.2.1.(4) by the following:

“A-2.4.2.1.(4) Soil-or-Waste Pipe Connections.

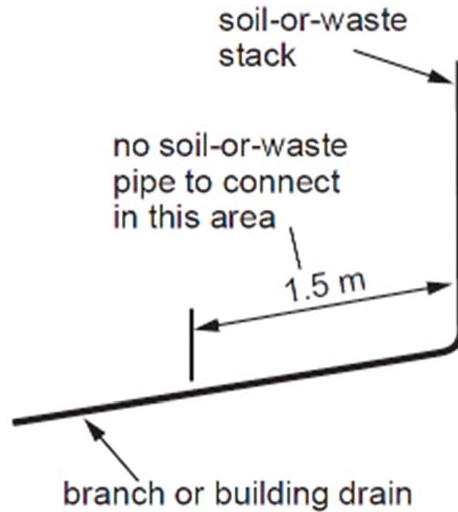

Figure A-2.4.2.1.(4)

Soil-or-Waste Pipe Connections

A-2.4.2.1.(5) Soil-or-Waste Pipe Connections.

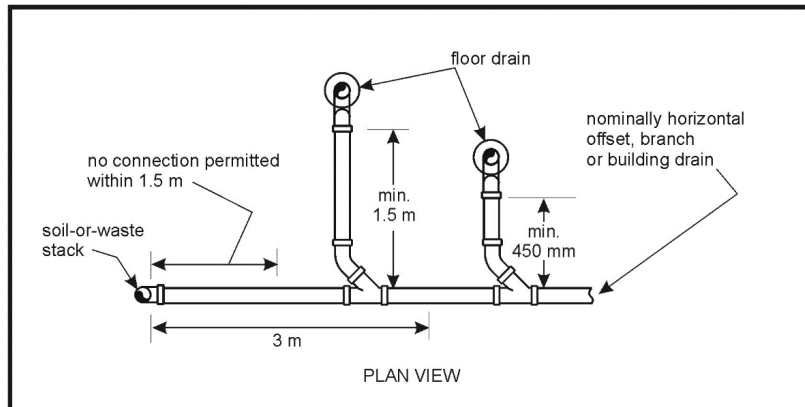

Figure A-2.4.2.1.(5)

Soil-or-Waste Pipe Connections

A-2.4.2.1.(6) and (7) Suds pressure zones. High sudsing detergents used in clothes washers produce suds that tend to disrupt the venting action of venting systems and can also spread through the lower portions of multi-storey drainage systems. The more turbulence, the greater the suds. One solution that avoids the creation of suds pressure zones involves connecting the suds-producing stack downstream of all other stacks and increasing the size of the horizontal building drain to achieve a greater flow of air and water. Using streamlined fittings, such as wyes, tends to reduce suds formation. Check valves or backwater valves in fixture outlet pipes have also been used to correct problem installations.

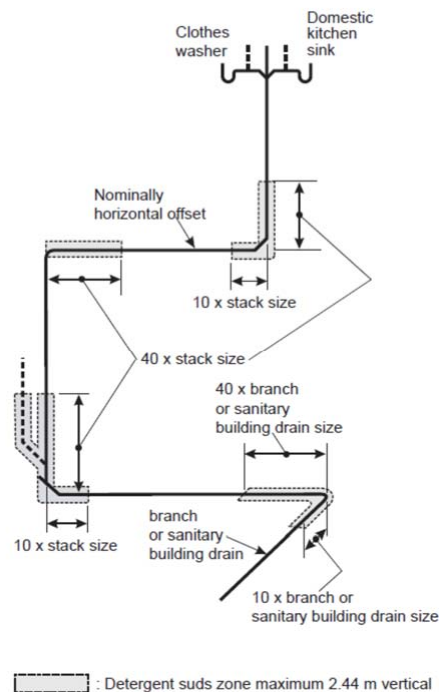

Figure A-2.4.2.1.(6) and (7)
Suds pressure zones

(75) by replacing note A-2.4.4.3.(1) by the following:

A-2.4.4.3.(1) Grease Interceptors. Grease interceptors may be required when it is considered that the discharge of fats, oil or grease may impair the drainage system. Further information on the design and sizing of grease interceptors can be found in ASPE document “Data Book – Volume 4, Chapter 8, Grease Interceptors” or in CAN/CSA-B481 Series.”;

(76) by replacing note A-2.4.5.3.(1) by the following:

“A-2.4.5.3.(1) Subsoil Drainage Connections. This Code does not regulate the installation of subsoil drainage pipes, but does regulate the connection of such pipes to the plumbing system. The intent of this Article is to place a trap between the subsoil drainage pipe and the storm water or combined system. The cleanout shall be installed in accordance with Sentence 2.4.7.1.(2).

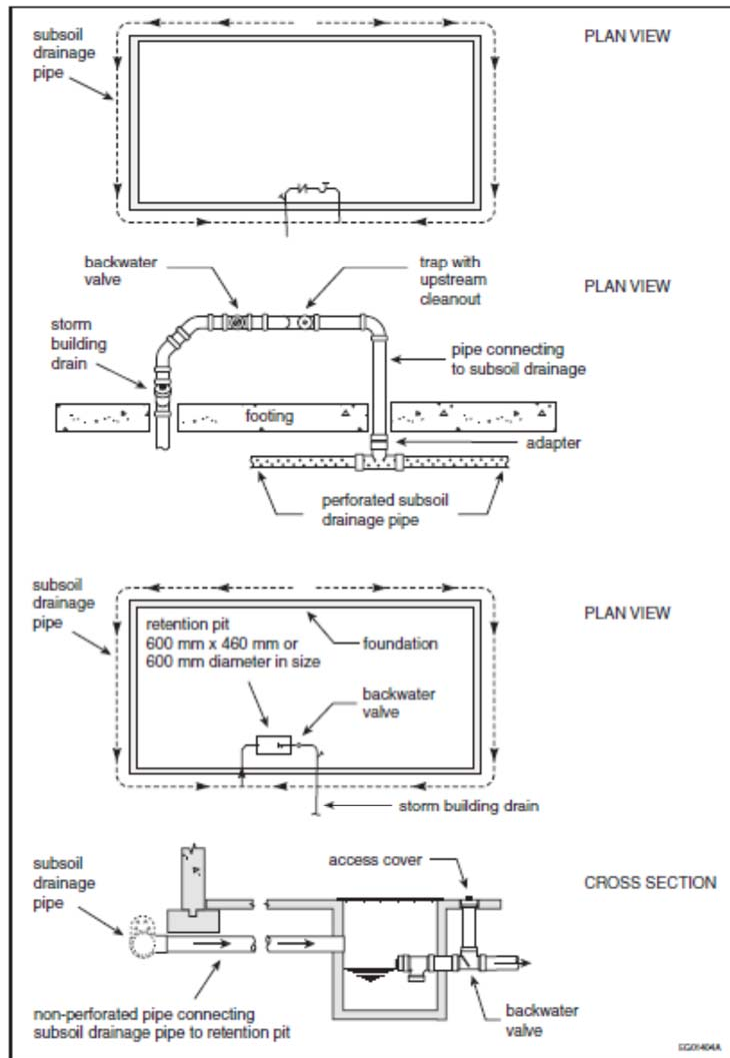

Figure A-2.4.5.3.(1)
Subsoil Drainage Connections

(77) in note A-2.4.5.5.(1), by striking out “Periodic manual replenishment of the water in a trap is considered to be an equally effective means of maintaining the trap seal in floor drains in residences.”;

(78) by inserting the following after note A-2.4.5.5.(1):

“A-2.4.5.5.(2) Maintaining Trap Seals in Floor Drains in Dwelling Units. Periodic manual replenishment of the water in a trap maintains the trap seal in floor drains in dwelling units.”;

(79) by striking out note A-2.4.6.4.(6);

(80) by replacing note A-2.4.8.2.(1) by the following:

“A-2.4.8.2.(1) Island Fixture Installation.

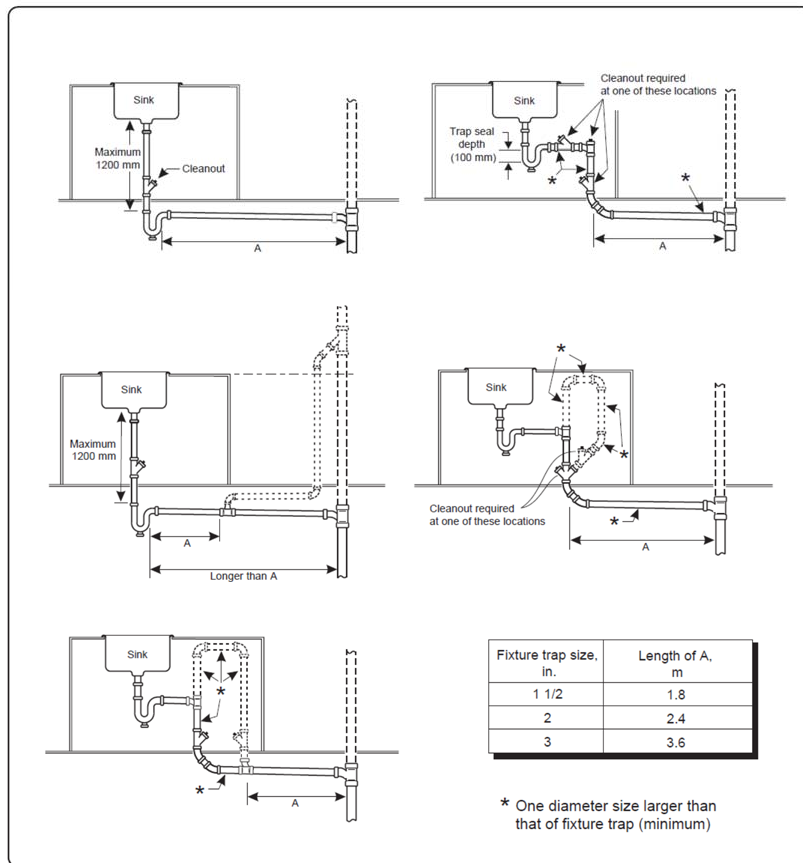

Figure A-2.4.8.2.(1)
Island Fixture Installation.

(81) in note A-2.5.2.1.,

(a) by replacing Figure A-2.5.2.1.-E by the following:

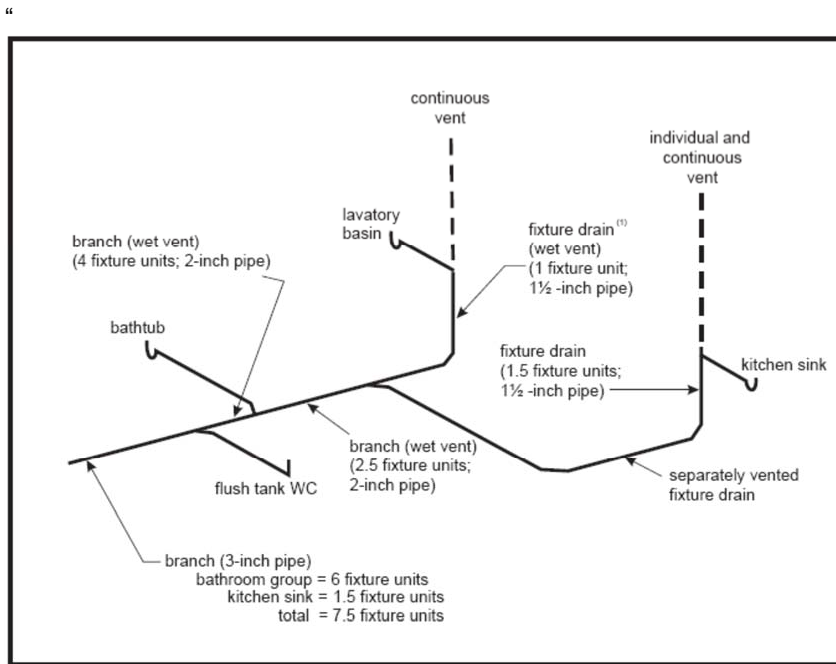

Figure A-2.5.2.1.-E
Example of Wet Venting Described in Clause 2.5.2.1.(1)(f)

(1) The load from the separately vented kitchen sink is included when sizing this pipe.

”;

(b) by replacing Figure A-2.5.2.1.-F by the following:

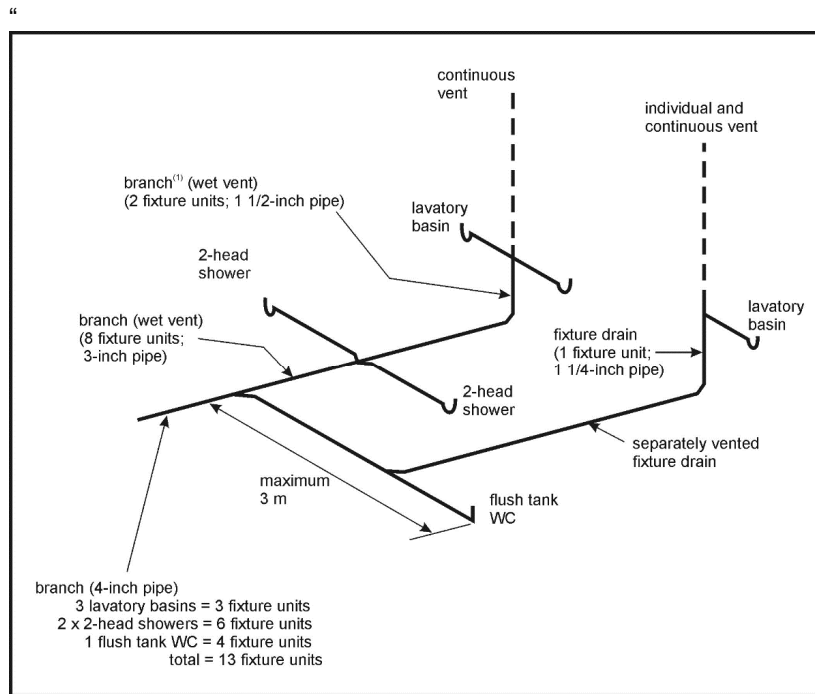

Figure A-2.5.2.1.-F
Example of Wet Venting Described in Clause 2.5.2.1.(1)(f)

(1) The load from the separately vented lavatory basin is included when sizing this pipe.

”

(82) by replacing note A-2.5.5.2. by the following:

“A-2.5.5.2. Venting of Oil Interceptors.

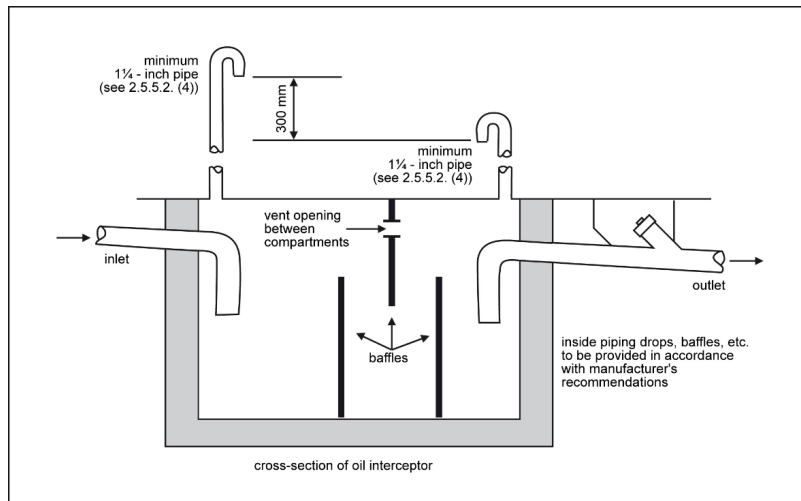

**Figure A-2.5.5.2.
Venting of Oil Interceptors**

”;

(83) by replacing note A-2.6.1.12.(1) by the following:

“A-2.6.1.12.(1) Service Water Heater. Water in a service water heater or in a distribution system that is kept at less than 60 °C permits Legionella bacteria to survive and thrive. Water heated at a temperature equal to or greater than 60 °C reduces bacterial contamination of the hot water distribution system.”;

(84) in note A-2.6.3.1.(2), by inserting the following after the title **“Method for Small Buildings”**:

““Small building” means a building of groups A, D, E, F2 or F3, as defined in Subsection 3.1.2., Division B of the NBC, not more than 3 storeys in building height (according to the definition of the NBC), and having a building area not more than 600 m².”;

(85) by striking out “and irrigating lawns and gardens” after “such as flushing toilets” in note A-2.7.4.1.

3.06. The Code is amended in Division C,

(1) by striking out Subsection 2.2.1.;

(2) by replacing Subsection 2.2.2. by the following:

“2.2.2. Plans and Specifications

2.2.2.1. Requirements

(1) A plumbing contractor or owner-builder may not begin construction work on a *plumbing system* to which Chapter III of the *Construction Code* applies unless there are plans and specifications for the work, if the total hydraulic load to be installed exceeds 180 *fixture units*.

(2) Sentence (1) does not apply to construction work on a *plumbing system* in a *building* to which Part 9 of Division B of the National Building Code, as adopted by Chapter I of the *Construction Code*, applies.

(3) When required, the plans and specifications shall be available on the worksite.

2.2.2.2. Content

(1) Plans shall be drawn to scale and show

(a) a plan view of the location and dimension of the drains and *cleanouts*, the location of *fixtures* and the *water distribution system*,

(b) an elevation view of the location of *fixtures* and *traps*, the dimension of drains, *leaders*, *soil-or-waste stacks*, *stack vents* and *vent stacks* as well as the *water distribution system*;

(c) the connection of the *subsoil drainage pipe* if it enters the *building*.”;

(3) by adding the following after Subsection 2.2.2.:

“2.2.3. Approval of Materials

2.2.3.1. Approved Materials, Fixtures and Facilities used in a Plumbing System

(1) In a *plumbing system*, only materials, fixtures or facilities that are certified or approved by one of the following organizations may be used:

- (a) Canadian Gas Association (CGA),
- (b) Bureau de normalisation du Québec (BNQ),
- (c) CSA Group (CSA),
- (d) IAPMO Group (UPC),
- (e) Underwriters’ Laboratories of Canada (ULC),
- (f) NSF International (NSF),

- (g) Canadian General Standards Board (CGSB),
- (h) Quality Auditing Institute (QAI),
- (i) Intertek Testing Services NA Ltd. (ETL),
- (j) Underwriters Laboratories Inc. (UL),
- (k) Water Quality Association (WQA),
- (l) ICC Evaluation Service (ICC-ES),

(m) any other organization accredited by the Standards Council of Canada as a certifying organization in the field of plumbing which has notified the Board of its accreditation.

2.2.3.2. Sale and lease

(1) Materials, fixtures or facilities that may be used in a *plumbing system* shall be certified or approved by an organization listed in Sentence 2.2.3.1.(1) before being sold or leased.

2.2.4. Declaration of Work

2.2.4.1. Application

(1) A plumbing contractor or owner-builder shall declare to the Board all construction work performed and to which Chapter III of the *Construction Code* applies if the work pertains to a new *plumbing system* or requires the replacement of a *service water heater* or pipes.

2.2.4.2. Submission of the Declaration

(1) The declaration required under Article 2.2.4.1. shall be forwarded to the Board not later than the twentieth day of the month following the date on which work starts.

2.2.4.3. Form

(1) The declaration of work shall be made on the form provided by the Board or on any other document prepared for that purpose.

2.2.4.4. Content

- (1) The declaration shall contain
 - (a) the address of the site where the work is performed,
 - (b) the name, address and telephone number of the person for whom the work is performed,

- (c) the name, address, telephone number and licence number of the plumbing contractor or owner-builder, where applicable,
- (d) the estimated start and end dates of the construction work,
- (e) the nature and type of the work,
- (f) the *occupancy* of the *building* or facility intended for use by the public and the existing and planned number of *storeys*, and
- (g) the number of fixtures and *service water heaters* to be installed.

2.2.5. Fees Payable

2.2.5.1. Calculation

(1) The following fees shall be paid to the Board by the plumbing contractor or owner-builder, when the plumbing contractor declares the construction work pertaining to *plumbing systems* for which a declaration is required under Article 2.2.4.1.:

- (a) \$159.80 for a new single-family detached or semi-detached house or row house,
- (b) \$96.74 per *dwelling unit* other than those covered by Clause (a) for the construction of a new *building* intended for housing or for the conversion of a *building* of another nature into a *building* intended for housing, regardless of the number of fixtures and *service water heaters*, or
- (c) in the case of work other than work covered by Clauses (a) and (b),
 - (i) \$12.83 per fixture or *service water heater*, where the work is performed on more than one, or
 - (ii) \$22.00 where the work is performed on only one or no fixture or *service water heater*.

(2) A plumbing contractor or owner-builder shall pay the following inspection fees to the Board for the inspection of a *plumbing system* following the issue of a remedial notice provided for in section 122 of the Building Act (chapter B-1.1):

- (a) \$107.94 for the first hour or any fraction thereof,
- (b) half the hourly rate established in Clause (a) for each half-hour or fraction thereof added to the first hour,

(3) A plumbing owner-builder shall pay to the Board the inspection fees fixed in Clauses (a) and (b) of Sentence (2) for the inspection of a *plumbing system*.

2.2.5.2. Sending

(1) The fees payable under Sentence 2.2.5.1.(1) shall be included with the declaration of work required under Article 2.2.4.1.

(2) The fees payable under Sentences 2.2.5.1.(2) and (3) shall be paid not later than 30 days after the billing date.”;

(4) by replacing Subsection 2.3.1. by the following:

“2.3.1. Approval of Alternative Solutions

2.3.1.1. Conditions for Approval

(1) The proposed alternative solutions shall be approved by the Board on the conditions it sets pursuant to section 127 of the Building Act (chapter B-1.1).”.

DIVISION III

OFFENCE

3.07. Every contravention against a provision of this Chapter, except Subsection 2.2.5 of Division C of the Code, introduced by paragraph 3 of section 3.06, constitutes an offence.”.

2. This Regulation comes into force on 27 March 2021.

However, the former provisions of Chapter III, Plumbing, of the Construction Code (chapter B-1.1, r. 2), as they read on 26 March 2021, may apply to construction work on a plumbing system that begins before 27 September 2021.

104865

Gouvernement du Québec

O.C. 77-2021, 27 January 2021

Travel Agents Act
(chapter A-10)

Certain temporary measures for the payment of the duties payable for a travel agent licence, a travel counsellor certificate and a travel agency manager certificate

Regulation respecting certain temporary measures for the payment of the duties payable for a travel agent licence, a travel counsellor certificate and a travel agency manager certificate

WHEREAS, under subparagraph *b* of the first paragraph of section 36 of the Travel Agents Act (chapter A-10), the Government may make regulations to prescribe the terms

and conditions of issue, maintenance, suspension, transfer or cancellation of a licence, the qualifications required of a person applying for a licence, the conditions to be met and the duties to be paid by that person, and the duties payable for the transfer of a licence or the amalgamation of two travel agents;

WHEREAS, under subparagraph *b.1* of the first paragraph of section 36 of the Act, the Government may make regulations to prescribe the terms and conditions of issue, renewal, suspension or cancellation of a travel counsellor certificate, and the qualifications required of a person applying for a certificate, as well as the conditions to be met and the duties to be paid by that person;

WHEREAS, under subparagraph *b.2* of the first paragraph of section 36 of the Act, the Government may make regulations to prescribe the terms and conditions of issue, renewal, suspension or cancellation of a travel